

NOTE: THROUGH SHAFT COVER IS NOT AVAILABLE IN THIS STYLE BRAKE.

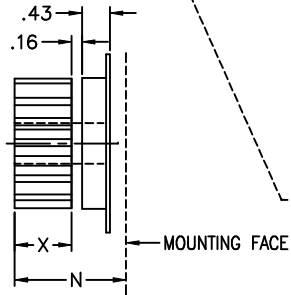

HUB AND V-RING HUB SEAL ASSEMBLY LOCATION DETAIL

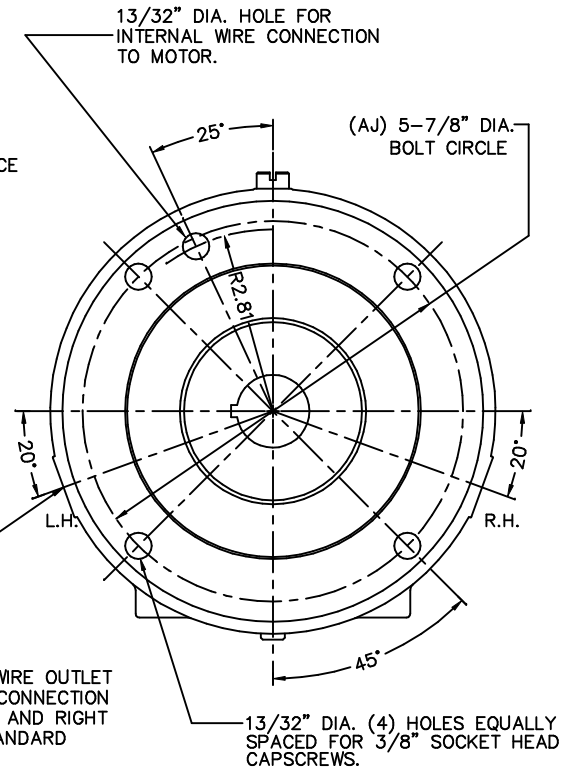
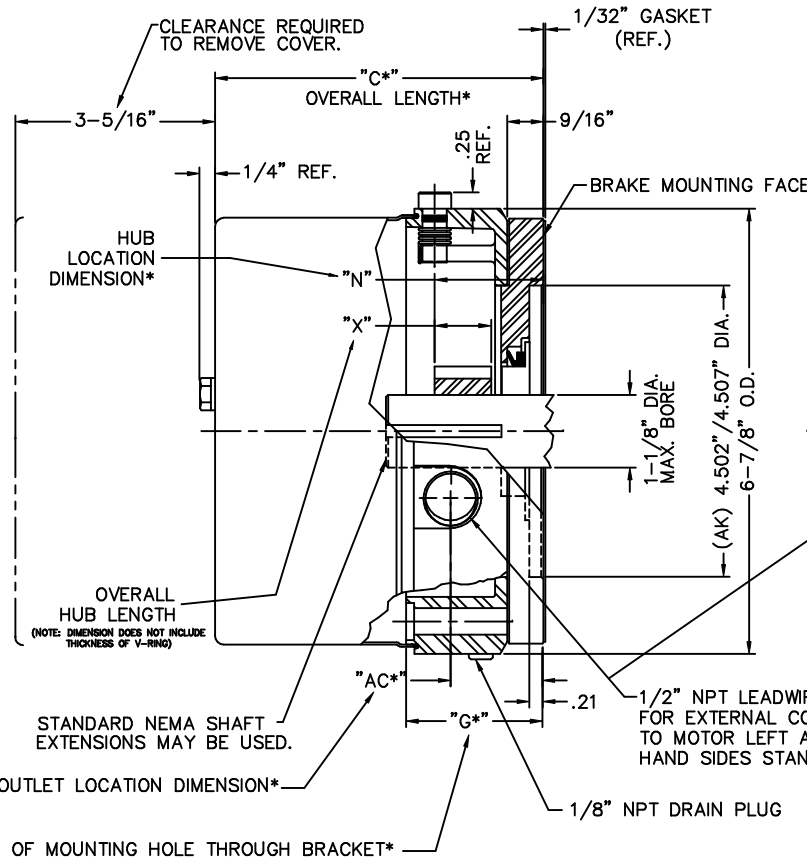

EXTERNAL WIRING OUTLET LOCATION DIMENSION\*  
LENGTH OF MOUNTING HOLE THROUGH BRACKET\*

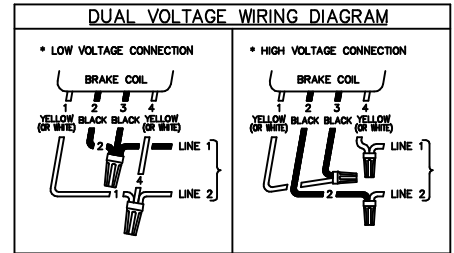

\*SEE BULLETIN BK4710 FOR OPERATING, INSTALLATION AND PARTS INSTRUCTIONS

MODEL NUMBER ENCLOSED HOUSING	NUMBER OF ROTATING DISCS	TORQUE LB.FT.	THERMAL CAPACITY HPS./MIN.	INERTIA OF ROTATING PARTS LB.FT. <sup>2</sup>	MAGNET AIR GAP		DIMENSIONS					COVER MATERIAL	BRACKET MATERIAL
					ORIGINAL SETTING	MAXIMUM	X	G*	AC*	C*	N*±1/32"		
6-61001-535	1	1.5	6	.006	.045/.050	.100	.88	1.78	1.18	4.72	1.68	STAMPED STEEL	ALUMINUM
6-61003-535	1	3	6	.006	.045/.050	.100	.88	1.78	1.18	4.72	1.68	STAMPED STEEL	ALUMINUM
6-62006-535	2	6	6	.011	.050/.055	.100	.88	1.78	1.18	4.72	1.68	STAMPED STEEL	ALUMINUM
6-62010-535	2	10	6	.011	.050/.055	.100	.88	1.78	1.18	4.72	1.68	STAMPED STEEL	ALUMINUM
6-63015-535	3	15	6	.017	.060/.065	.100	1.19	2.15	1.55	5.10	2.00	STAMPED STEEL	ALUMINUM
6-63020-535	3	20	6	.017	.060/.065	.100	1.19	2.15	1.55	5.10	2.00	STAMPED STEEL	ALUMINUM

\*NOTE: WHEN APPLICABLE, TABLE DIMENSIONS ARE REFERENCED FROM THE BRAKE MOUNTING FACE AND DO NOT INCLUDE THE GASKET THICKNESS.

E 2323 9-26-07 JEB INTERNAL WIRE HOLE WAS OPTIONAL		TOLERANCE UNLESS OTHERWISE NOTED		
D 2280 4-13-07 EBP CORRECTED "Y" DIMENSIONS ON CHART	REV A - FULL		PARTS BY: [ ] DRAWN BY: [ ] DATE: 8/21/99 FULL	
C 2226 8-18-08 JEB UPDATED DRAWING	REV B - FULL		DATE: 8/21/99 FULL	DRAWING NO. L060346 REV. NO. [ ]
B 1971 7-12-00 BHM ADDED TABLE	REV C - FULL		DATE: 8/21/99 FULL	CAD FILE: L060346
A 1920 2-21-00 CS UPDATED BRACKET	REV D - FULL		DATE: 8/21/99 FULL	CAD FILE: L060346
REV CHG# DATE BY	REVISION			