



70 Series Double "C" Face Brake Instructions



INSTALLATION

Refer to Figures 1 & 2
Insert key into motor shaft keyway. Key length to be as shown below for models designated.

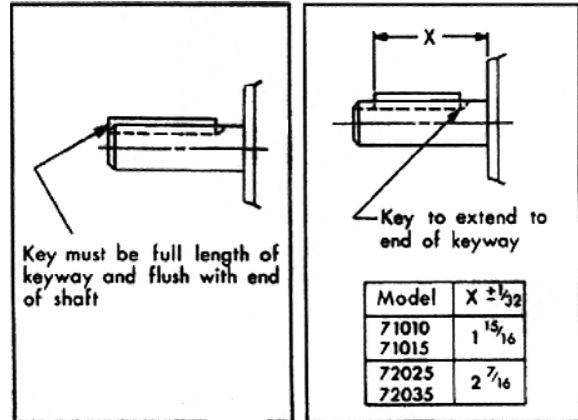

IMPORTANT

Read carefully before attempting to assemble, install, operate or maintain the product described. Protect yourself and others by observing all safety information. Failure to comply with instructions could result in personal injury and/or property damage! Retain instructions for future reference. When unpacking the brake, inspect it carefully for damage that may have occurred during transit.

Used on all models except 71010, 71015, 72025, and 72035 with 1-1/8" dia. shaft. For models 71010, 71015, 72025 and 72035 with 1-1/8" dia. shaft.

Slide brake onto motor shaft, aligning key in motor shaft with keyway in brake shaft. Secure brake to motor "C" face with four 1/2" socket head capscrews. Connect coil leads per appropriate diagram.

WARNING

Brake performance and features must be carefully matched to the requirements of the application.

Consideration must be given to torque requirements, especially where an overhauling condition exists, as well as thermal capacity, ambient temperature, atmospheric explosion hazards, type of enclosure and any other unusual conditions.

Improper selection and installation of a brake and/or lack of maintenance may cause brake failure which could result in damage to property and/or injury to personnel.

If injury to personnel could be caused by brake failure, additional means must be provided to insure safety of personnel.

DESCRIPTION

This brake is direct acting, electromagnetically released and spring set. It uses rotating and stationary disc contact to supply positive braking action. It retains quick release and setting capabilities at all times.

Simplicity of design has reduced maintenance to an absolute minimum. As with any electromechanical equipment, however, periodic inspection and adjustment will assure optimum performance. As the friction disc wears, the magnet gap will increase. The magnet gap should be checked periodically and adjusted when necessary. This brake is offered in 2 housing styles: Standard (NEMA 2) and Enclosed (NEMA 4).

THREE PHASE

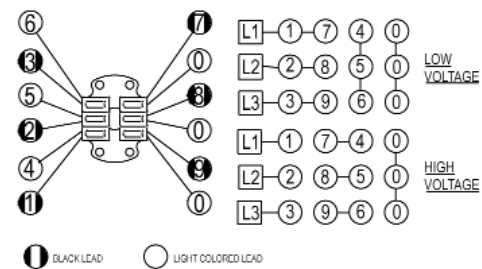

SINGLE PHASE

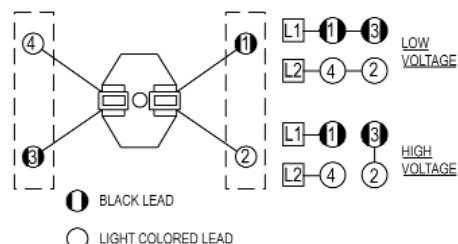

Figure 1. Wiring Diagram

MANUAL RELEASE

(See Figure 4)

To operate release, rotate two nuts (16) clockwise until stop screw (14) hits pin. Brake will remain in released position until rods are manually returned to original position, or until electrical power is restored, automatically resetting the brake.

TORQUE ADJUSTMENT

(See Figures 2 & 4–Table 1)

Brake is factory set for rated torque per spring length “H”. To increase stopping time and lower torque, turn two locknuts (9) counterclockwise, increasing dimension “H”. Both springs must be set to the same length. Do not decrease spring length “H” as this may cause coil to burn out.

MAINTENANCE AND SERVICE

WEAR ADJUSTMENT

(See Figures 2 & 4– Table 1)

Magnet gap “D” increases as friction discs wear. When gap approaches “D” max., adjust gap to “D” min. dimension by turning nuts (23 and 24). Magnet gap can vary from nominal ± .005” between corners. After setting gap, readjust torque spring length “H”.

CAUTION: MAGNET GAP MUST NOT EXCEED “D” MAXIMUM.

FRICITION DISC REPLACEMENT

(See Figure 4 & Table 1)

When the rotating friction disc (4) wears down to a thickness of 7/32”, replace disc. Remove brake from its associated equipment (reducer-motor-etc.). Remove retaining ring (28) and press shaft (1) out of bearing in brake case (25). A wheel puller, utilizing openings in side of case, can be used. Continue disassembling in this order: two nuts (26), brake case (25), roll pins (17), manual release knobs (16), manual release screws (14), manual release washers (12), manual release shims(13), two nuts (24), magnet mounting plate assembly (18), two nuts (23), two nuts (9), torque spring washers (8), torque springs (7), pressure plate assembly (6) and discs (4) (5).

Lay bracket (2) on a flat table. Place shaft (1) in center of bracket, with a spacer under hub. Spacer thickness to be 13/16”. Replace worn friction discs (4) and reassemble disc pack. Continue reassembling in reverse order, setting torque spring dimension “H,” and magnet gap “D” min. (Table 1.). When assembling manual release, turn release rod (10) counter-clockwise until screw (14) strikes pin. Wind torsion spring (11) about 1/4 turn and hook spring over pin.

NOTE: When assembling manual release mechanism, add only enough shim washers (13) to obtain proper release action. With too many shim washers, brake will not automatically reset when electrical power is applied. With too few shim washers, motor shaft will not turn freely with brake in manually release position.

IMPORTANT: Make sure release is working properly before proceeding.

Place case (25) over shaft (1). Release brake by turning two nuts (16) clockwise. Press bearing (in case) onto shaft by applying pressure to bearing inner race. Complete assembly in this order: snap ring (28) and two nuts (26).

NOTE:. Units with 1-3/8” dia. output shafts—remove brake case by first removing outside retaining rin (41) and two nuts (26). Then press shaft (1) out of bearing. Next remove remaining retaining ring (41) and pull shaft out of brake.

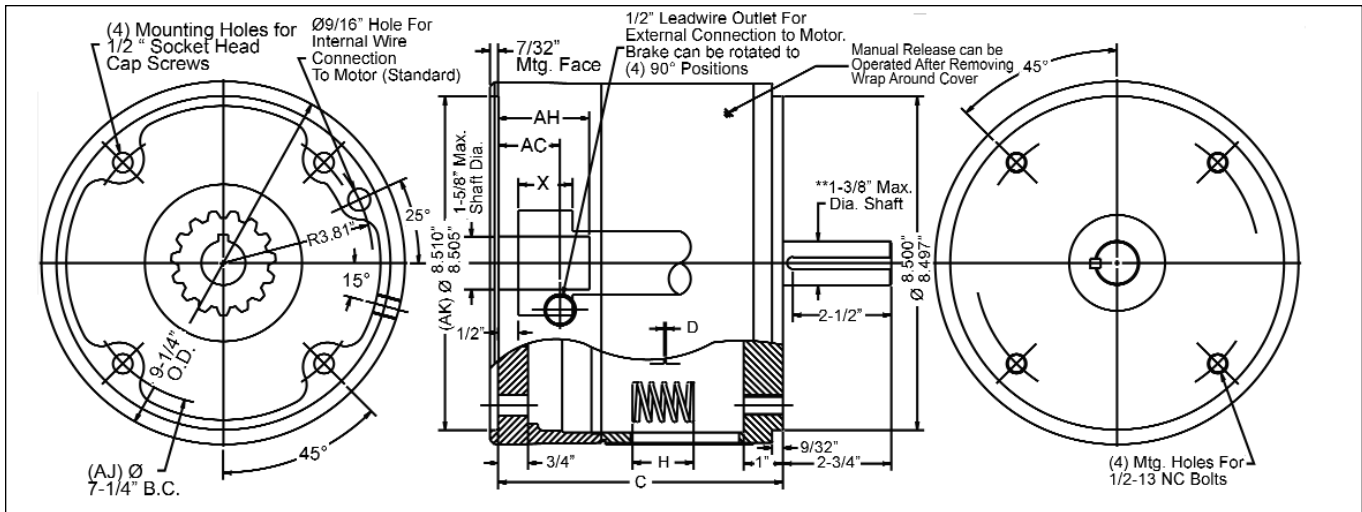

Figure 2. Outline Drawing

MODEL NUMBER NEMA 2	MODEL NUMBER NEMA 4	Torque Lb.Ft.	Weight lbs.	Thermal Capacity HPS/Min	Inertia WK ² LB-FT ²	DIMENSIONS								
						AC	C	D		H	AH (Motor Shaft Length)			
								Max.	Min.		1.125 Dia.		1.375 Dia.	
											Max.	Min.	Max.	Min.
6-71010-38	4-71010-46	10	45	11	.069	1.19	6.84	.07	.03	1.31	2.81	2.50	*1.81	*1.69
6-71015-38	4-71015-46	15	45	11	.069			.07	.03				.07	.035
6-72025-38	4-72025-46	25	49	12	.110	1.63	7.47	.07	.035	1.31	2.81	2.50	3.13	2.94
6-72035-38	4-72035-46	35	49	12	.110			.07	.035				.07	.040
6-73050-38	4-73050-46	50	53	13	.150	2.25	8.09	.07	.040	1.25				
6-74075-38	4-74075-46	75	57	14	.190	2.88	8.72	.07	.040	1.21				

*Std. NEMA Motor Shafts will have to be shortened.

MAGNET COIL REPLACEMENT

(See Figures 1, 3 & 4)

Remove magnet assembly as outlined under FRICTION DISC REPLACEMENT.

Coils (21) are held in place with epoxy cement. Force coil off magnet mounting plate and remove excess epoxy from all surfaces.

Replacement coils should be held in place with new epoxy cement. The epoxy cement should be heat resistant and shock resistant. Place an insulating washer (20) below the coils. Order insulating washers when ordering coils. An insulating washer can be cut to suit when replacing only one coil on a multiple coil assembly.

When installing coils, it is very important to follow EXACTLY the sequence of black and light colored leads as shown in wiring diagram (Figure 1). The brake will not operate properly unless coils are all in the correct position.

Reassemble all parts in reverse order.

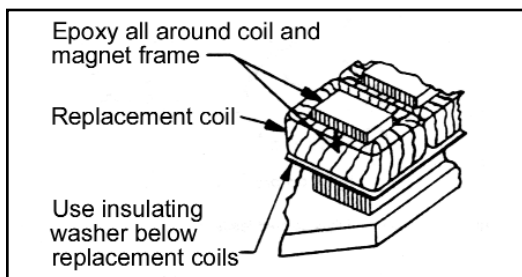

Figure 3. Fastening of Replacement Magnet Coils

TROUBLE SHOOTING

A. IF BRAKE DOES NOT RELEASE:

1. Check brake visually for broken or damaged parts.
2. Check for broken leadwire or bad electrical connection.
3. Check for correct voltage. Line voltage must correspond to the voltage for which the brake coils are connected. If the line voltage is more than 10% below the voltage for which the brake coils are connected, the magnet will not pull in, causing the coils to burn out within minutes. If the line voltage is more than 10% above the voltage for which the brake coils are connected, the coils will overheat and burn out.
4. Check for burned-out coils (coils may be charred or burned).
5. Check for excessive magnet gap. (See WEAR ADJUSTMENT.)
6. Check for failure or power supply to brake.

B. IF BRAKE DOES NOT STOP:

1. Check brake visually for broken or damaged parts.
2. Make certain hub has not shifted position on the motor shaft and that all rotating discs are fully engaged on the hub.
3. Check that the manual release is in the normal position.
4. Check disc wear. (See WEAR ADJUSTMENT.)

C. IF BRAKE CHATTERS OR HUMS:

1. See that magnet faces are clean. To remove dirt, insert a clean sheet of paper between magnet faces and energize brake. Move paper around between faces to dislodge dirt, then remove paper.
2. Check for low voltage. Magnet will not pull in, and coils will burn out if line voltage is beyond 10% below the voltage the brake coils are connected for.
3. See that magnet faces are parallel within tolerance. Readjust magnet gap to "D" min. (See WEAR ADJUSTMENT.)
4. Check if shading coil (22) is cracked, broken or out of position (single phase only).

D. IF MANUAL RELEASE DOES NOT WORK:

1. Check for broken or damaged parts.
2. Check return spring (11). Brake will not reset automatically if this spring is broken.
3. Check quantity of shim washers (13) under release stop screws. (See Manual Release Assembly under "FRICTION DISC REPLACEMENT".)

SPECIFICATIONS

MOTOR FRAMES - 182TC, 184TC, 213TC, 215TC, 254TC, 256TC.

ENCLOSURES - NEMA 2 or NEMA 4

(material: aluminum and cast iron)

DUTY - Rated for continuous duty.

VOLTAGES - All standard NEMA voltages and frequencies available. Other voltages and frequencies are optional.

MOUNTING - Direct to NEMA "C" face, with one additional "C" face for mounting of equipment to brake. Some standard motor shafts may need modification, see Table 1.

Horizontal or vertical mounting with modifications.

ORDERING INFORMATION

The following data should be furnished with your order for:

REPLACEMENT PARTS

Brake Model Number

Part Number from Tables

Part Description from Tables

Hub Bore & Keyway. Shaft Extension Diameter & Keyway.

For electrical parts specify voltage, phase, and frequency.

REPLACEMENT BRAKE

Model Number

Voltage, Phase & Frequency

Hub Bore & Keyway Dimensions. Shaft Extension Diameter & Keyway.

Mounting - Horizontal or Vertical. (If vertical, specify whether above or below motor.)

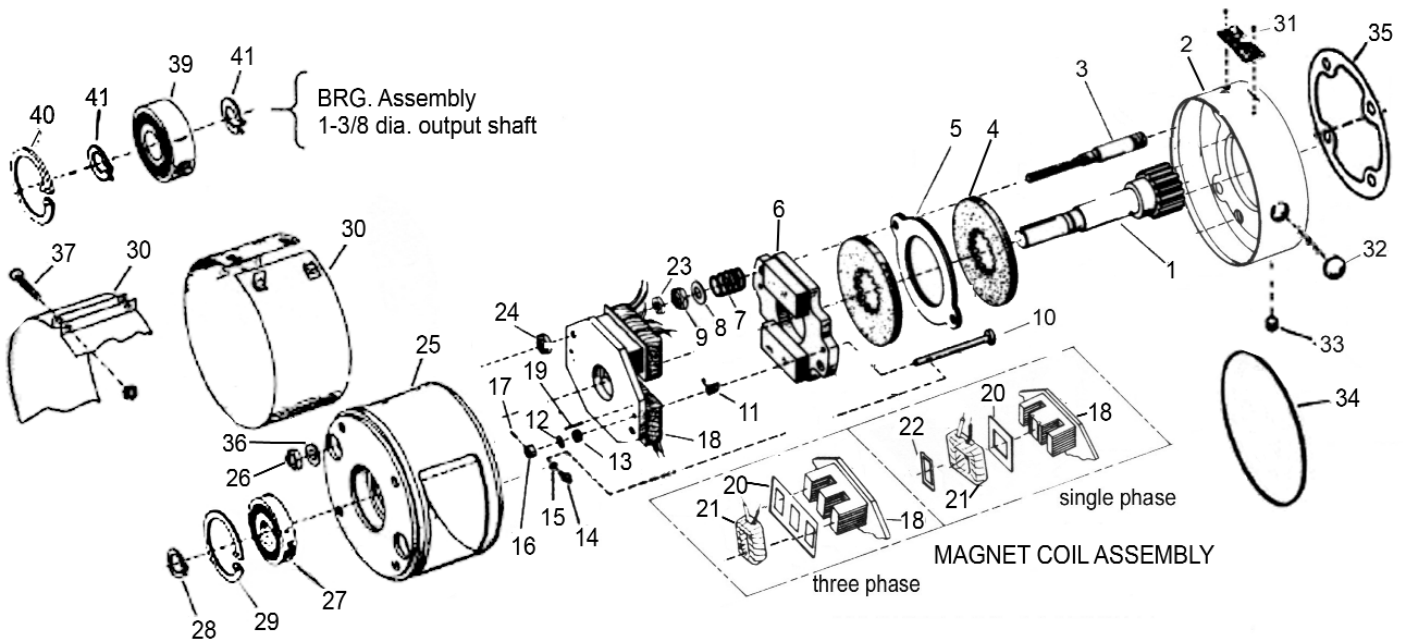

ITEM NO.	PCS. REQ'D	DESCRIPTION	PART NUMBER	
			NEMA 2	NEMA 4
1	1	Hub and Shaft Assembly (Specify both diameters and keyways)	Consult Factory	
2	1	Bracket (Specify brake model no.)	L070203	
3	2	Studs (Specify brake model No.)	H070180	
4	*	Rotating Friction Disc	H070103	
5	**	Stationary Disc	K070485-001	
6	1	Pressure Plate Assembly	K070045-001	
7	2	Torque Spring (10 Lb. Ft.)	G070011-001	
7	2	Torque Spring (25 Lb. Ft.)	G070019-001	
7	2	Torque Spring (15, 35, 50, 75 Lb. Ft.)	G070012-001	
8	2	Torque Spring Washer	W004004-001	
9	2	Torque Adjusting Nut	W003001-022	
10	2	Manual Release Rod	G070001-002	
11	2	Manual Release Spring	G060010-001	
12	2	Manual Release Washer	W004004-003	
13	As Req'd	Manual Release Shims -.006" Thick	W004004-004	
14	2	Manual Release Stop Screw	G060029-001	
15	2	Manual Release Lockwasher	W004007-007	
16	2	Manual Release Knob	G070471-001	
17	2	Roll Pin, 3/32" x 9/16" Lg.	W005003-039	
18	1	Magnet Mounting Plate Assembly For 3-Phase Magnets (Includes items 19 through 22)	K070097	
18	1	Magnet Mounting Plate Assembly For 1-Phase Magnets (Includes items 19 through 22)	K070335	
19	2	Roll Pin, 5/32" x 1-1/8" Lg.	W005003-109	
20	2	Insulating Washers, 3-Phase Coils	G070037-001	
20	2	Insulating Washers, 1-Phase Coils	G070029-001	
21	2	Coils-Single Phase (See Ordering Info.)	H070013	
21	6	Coils-Three Phase (See Ordering Info.)	H020003	
22	2	Shading coil (Single phase only)	G070032-001	
23	2	Hex Jam Nut 1/2"-20	W003003-023	
24	2	ESNA Locknut 1/2"-20	W003001-020	
25	1	Adapter Housing (1-1/8" output shaft)	L070202-002	
25	1	Adapter Housing (1-3/8" output shaft)	L070212-002	
26	2	ESNA Locknut 1/2"-20	W003001-020	
27	1	Ball Bearing-Double Seal (1-1/8" Output Shaft)	W009001-002	
28	1	Retaining Ring (1-1/8" output shaft)	W006004-001	
29	1	Retaining Ring (1-1/8" output shaft)	W006002-002	
30	1	Wrap Cover	K070228-001	K070279-001
31	1	Nameplate with Two Drive Screws	K060473-001	
32	1	Cap Plug	W008003-001	
33	1	Pipe Plug - 1/8" NPT	W010002-001	
34	1	"O" Ring	W006001-010	
35	2	Gasket for Brake Mounting	K070250	
36	2	Gasket	W011004-001	
37	2	RD. HD. Screw, #10 -32 x 1" Lg.	W001002-080	
38	2	Hex Nut #10-32	W003001-011	
39	1	Ball Bearing-Double Seal (1-3/8" Output Shaft)	W009001-003	
40	1	Retaining Ring (1-3/8" Output Shaft)	W006002-003	
41	2	Retaining Ring (1-3/8" Output Shaft)	W006007-003	

Table 2. Parts List

* Number of rotating discs is shown in model number.

Example: 6-72025-38 has two rotating discs.

** Number of stationary discs is one less than the number of rotating discs.

Dings
DYNAMICS GROUP

4740 WEST ELECTRIC AVENUE
MILWAUKEE, WI 53219
PHONE 414/672-7830 FAX 414/672-5354
www.dingsbrakes.com