



60 Series Double C Brake Instructions

Enclosed Housing

Read carefully before attempting to assemble, install, operate or maintain the product described. Protect yourself and others by observing all safety information. Failure to comply with instructions could result in personal injury and/or property damage! Retain instructions for future reference. When unpacking the brake, inspect it carefully for damage that may have occurred during transit.



DESCRIPTION

This 60 Series magnetic disc brake is used on 56C, 143TC and 145TC face motors and speed reducers. The brake is direct acting, electro-magnetically released, and spring set. It uses rotating friction and stationary disc contact to supply positive braking action. It retains quick release and setting capabilities at all times.

Warning: Do not install or use these brakes in an explosive atmosphere.

DIMENSIONS Figure 1

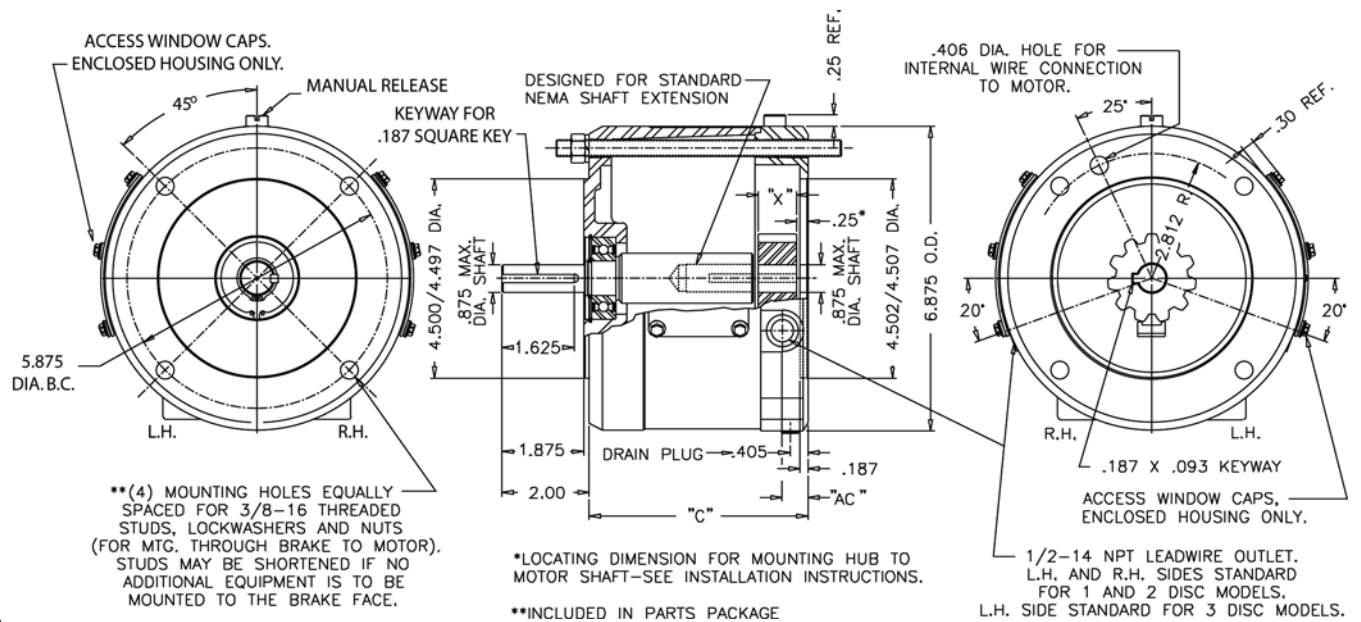

G061031

Model Number	Number of Rotating Discs	Torque Lb-ft	Thermal Capacity HPS/Min.*	Inertia of Rotating Parts Lb-Ft ²	Dimensions			
					C	AC	X	
							1-Piece Shaft	2-Piece Shaft
4-61001-5153	1	1.5	6	.006	4.937	.585	.81	.88
4-61003-5153	1	3	6	.006	4.937	.585	.81	.88
4-62006-5153	2	6	6	.010	4.937	.585	.81	.88
4-62010-5153	2	10	6	.010	4.937	.585	.81	—
4-63015-5153	3	15	6	.014	5.312	.873	1.19	—
4-63020-5153	3	20	6	.014	5.312	.873	1.19	—

* Thermal capacity (HPS/MIN.) was determined under the following test conditions: a) Room temperature 72°F. b) Stopping time of one second or less. c) Brake mounted in a horizontal position. d) Equal on and off times. e) 1800 RPM. f) Coil energized with 110% of rated voltage.

WARNING:

Brake performance and features must be carefully matched to the requirements of the application.

Consideration must be given to torque requirements, especially where an overhauling condition exists, as well as thermal capacity, ambient temperature, atmospheric explosion hazards, type of enclosure and any other unusual conditions.

Improper selection and installation of a brake and/or lack of maintenance may cause brake failure which could result in damage to property and/or injury to personnel.

If injury to personnel could be caused by brake failure, additional means must be provided to insure safety of personnel.

UNPACKING

When unpacking the brake, inspect it carefully for damage that may have occurred during transit.

GENERAL SAFETY INFORMATION

NOTE: These brakes are not intended for accurate positioning applications. They are designed for applications that require rapid stopping and holding power, such as on conveyors, door openers, etc.

1. For applications with high inertia-type loads or rapid cycling, the thermal capacity of the brake must be considered.
2. Observe all local electrical and safety codes, as well as the National Electrical Code (NEC) and the Occupational Safety and Health Act (OSHA).
3. Brake motors and brake gearmotors must be securely and adequately grounded. This can be accomplished by wiring with a grounded metal-clad raceway system, by using a separate ground wire connected to the bare metal of the motor frame, or other suitable means. Refer to NEC Article 250 (Grounding) for additional information. All wiring should be done by a qualified electrician.
4. Always disconnect power before working on or near a brake motor, a brake gearmotor, or its connected load. If the power disconnect point is out of sight, lock it in the open position and tag it to prevent unexpected application of power.
5. When working on the brake, be sure the load is completely removed, secured or blocked to prevent injury or property damage.
6. Provide guarding for all moving parts.
7. Be careful when touching the exterior of an operating motor, gearmotor or brake. It may be hot enough to cause injury or to be painful. This condition is normal for modern motors, which operate at higher temperatures when running at rated load and voltage.
8. Protect all electrical lead wires and power cables against contact with sharp objects or moving parts.
9. Do not kink electrical lead wires and power cables, and never allow them to touch oil, grease, hot surfaces or chemicals.

INSTALLATION

CAUTION: To preserve pre-alignment of rotating discs for ease of installation, do not operate manual release or energize brake coil before installation.

NOTE: The brakes are designed for horizontal mounting. Modification is required for vertical mounting. Brakes that are modified will have a prefix on the model number of VO (Vertical Over), VU (Vertical Under), or V (Vertical Over or Under).

On enclosed models, the brake drain should be located at the bottom. If the application causes excessive condensation build-up, vertical mounting below the motor is not recommended.

Number in parentheses refer to parts illustrated in Figs. 3, 4, 6, 7 and 10.

Placing Brake on Motor C Face

For models with two-piece shaft design:

1. Mount hub (22) over key on motor shaft 1/4" from the motor mounting face as shown in Fig. 1. Part number on hub to face away from motor. Use 3/16" square key furnished. Key must extend to, and be flush with, end of motor shaft. Tighten both setscrews in hub with 8 to 10 lb. ft. torque.
2. Place gasket (34) on motor C face.
3. Remove adapter housing (7). You may have to remove the access window cap assemblies (9) and tap lightly with a soft mallet in the openings in the side of the adapter housing. Place the brake assembly onto the motor C face, engaging hub splines into brake disc splines. The release should be located at the top.
4. Screw in four 3/8-16 threaded rods (28) or (32) through bracket (1) into motor C face (approx. 9/16" engagement or 9 turns). Bring coil lead wires out of conduit hole before installing the adapter housing. Align adapter housing (7) with four threaded rods. NOTE: Arrow head on adapter housing should be in line with manual release knob (15); see Fig. 10.

Slide adapter housing onto threaded rods, turning output shaft (8) so that the keyway in the brake shaft lines up with the key in the motor shaft. Make sure adapter housing seats against the bracket (1).

Tap adapter housing in place lightly. If excessive force is required, the key may have to be filed.

5. If additional equipment is to be used, such as a gear reducer, install a key into the brake shaft extension. Install gasket (34) onto the brake C face.

Slide equipment onto threaded rods, aligning key in the brake shaft with keyway in the additional equipment.

Fasten with lockwashers (29) and nuts (30).

6. If no additional equipment is used, fasten adapter housing (7) with items (29) and (30). The threaded rods may be cut off the suit the application.

For models with one-piece shaft design:

1. Place 3/16" square key furnished into motor keyway. Key must extend to, and be flush with, end of motor shaft. Place gasket (34) on motor C face.
2. Place brake assembly onto the motor shaft, aligning the brake shaft keyway with key in the motor shaft. If the key wants to ride up at the end of the motor shaft keyway, push the key into the brake shaft with a screwdriver.

Do not use excessive force to seat the brake against the motor. If excessive force is required, the key may have to be filed.

Brake bracket (1) must be flush with the motor mounting face and adapter housing (7) must seat against the bracket (1).

NOTE: Arrow head on adapter housing should be in line with manual release knob (15); see Fig. 10. The release should be located at the top.

3. Screw in four 3/8-16 threaded rods (28) or (32) through housing (7) and bracket (1) into motor C face (approx. 9/16" engagement or 9 turns).
4. If additional equipment is to be used, such as a gear reducer, install a key into the brake shaft extension. Install gasket (34) onto the brake C face.

Slide equipment onto threaded rods, aligning key in the brake shaft with keyway in the equipment. Fasten with lockwashers (29) and nuts (30).

5. If no additional equipment is used, fasten brake assembly with items (29) and (30). The threaded rods may be cut off to suit the application.

Connection of Coil Leads

After securing the brake to the motor, connect coil leads for proper voltage per wiring diagram. (Fig. 2 shows dual voltage coil). Incorrect connection can result in brake failure.

CAUTION: The voltage supplied to the coil must match the voltage that the coils are connected for, or the coils will burn out.

Single voltage coil:

Connect brake coil leads to any two line leads (single or three phase) of same voltage and frequency as brake.

Dual voltage coil:

Connect leads 2 and 4 to any two motor line leads (single or three phase) of same voltage as brake. Connect leads 1 and 3 as shown for voltage desired. Brake must be energized with motor.

OPERATION

These brakes are spring set devices with an electrical (magnet) release. They contain a rotating friction disc that is driven by a hub mounted on the motor shaft. When energized, the magnet compresses the torque springs, removing the force pressing the stationary disc and friction disc together. This permits free rotation of the shaft.

WARNING: Observe proper safety precautions in applications where a brake failure would allow the load to move in such a manner as to injure personnel. KEEP PERSONNEL AWAY FROM LOAD AREAS.

If brake torque rating is higher than motor full-load torque rating, use brake rating rather than motor rating when selecting other drive components.

Take the following precautions when operating the brake:

1. Do not operate the brake at higher than nominal static torque capacity.
2. For applications with high inertia-type loads or rapid cycling, the thermal capacity of the brake must be considered.
3. High start-stop rates may damage motor. Consult motor manufacturer if high cycling rates are expected.
4. Be sure power supply conforms to electrical rating of brake.

Manual Release

The brake is equipped with a manual release. Turn the release knob (15) clockwise to stop position to release the brake. The brake will remain released until the release knob is turned counterclockwise (approx. 65°) or until the brake coil is energized, automatically resetting the brake.

Wiring Diagrams

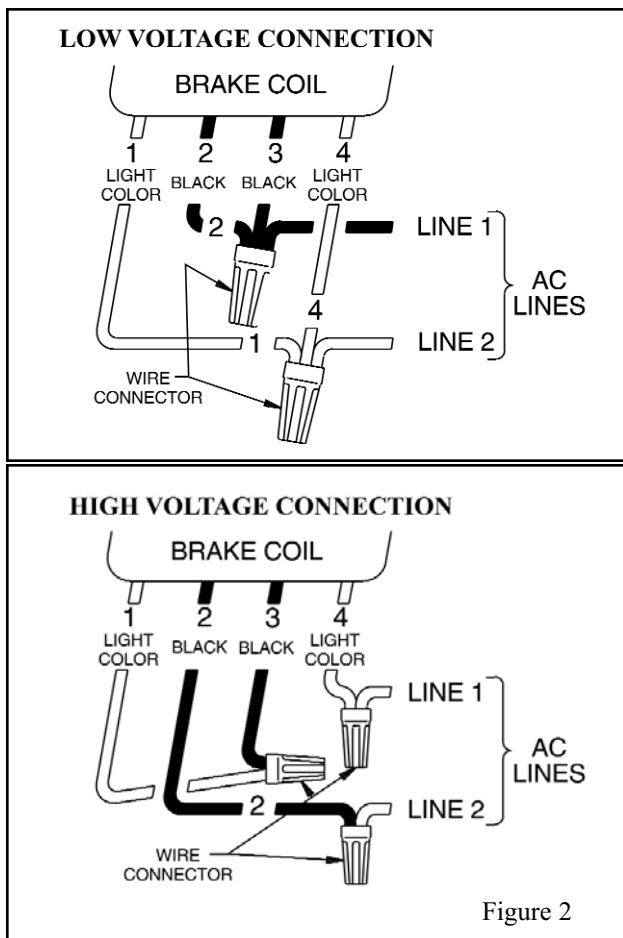
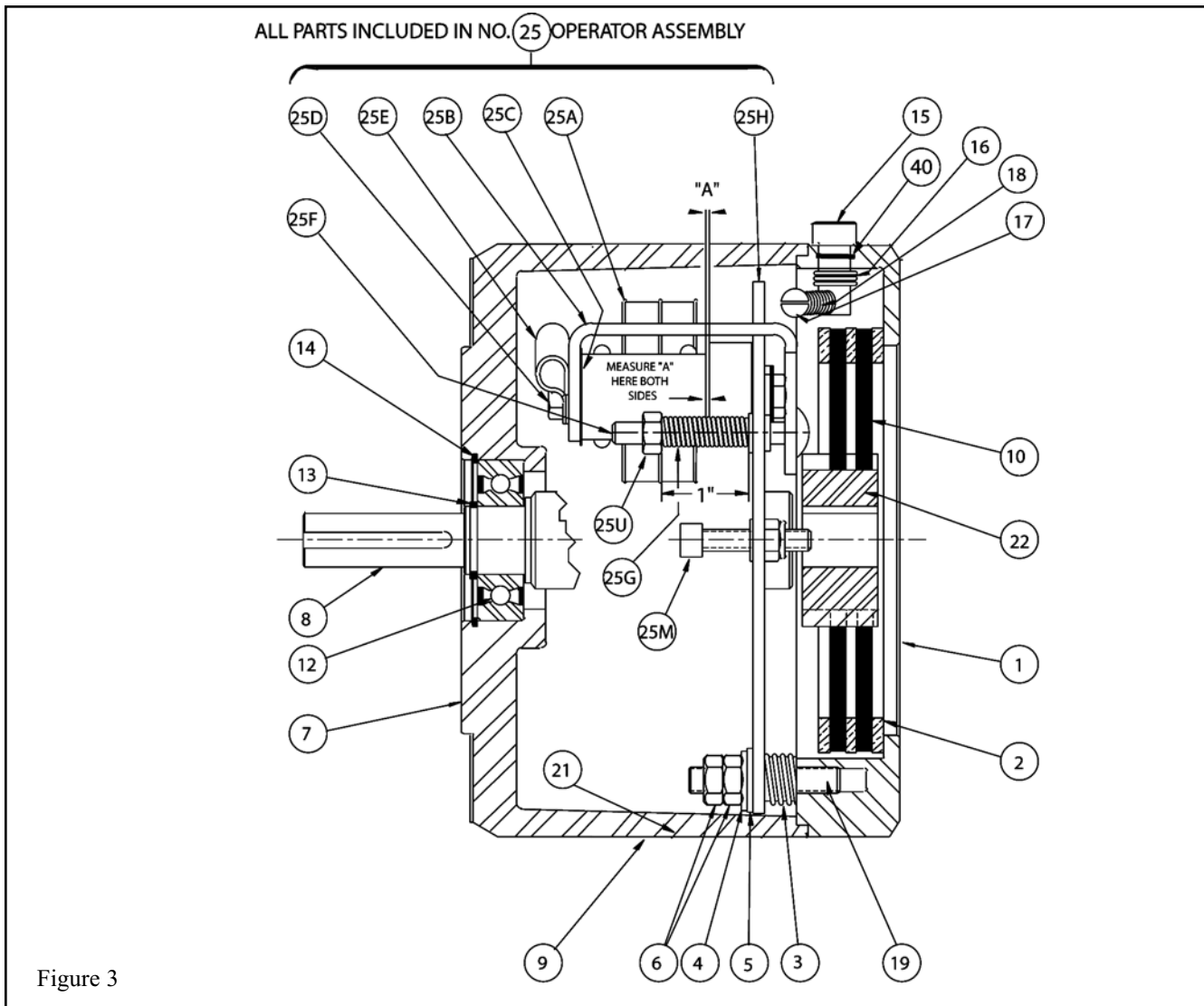

Figure 2



MAINTENANCE

Caution: Before attempting to service or remove any components, make certain that the power is disconnected and that the load is completely removed, secured or blocked to prevent injury or property damage.

Wear Adjustment

Caution: Load to be removed or blocked. Brake may be inoperative during this procedure.

Before air gap "A" reaches .100", adjustment is required. Any delay in adjusting the magnet air gap will result in eventual loss of torque.

Refer to Figs. 3 and 4.

1. To adjust, remove access window cap assemblies (9) to expose adjusting screws (25M) and magnet air gap "A".
2. Measure air gap "A" using 3/8" to 1/2" wide feeler gauge as shown in Figs. 3 and 4.

3. Turn two square head adjusting screws (25M) until air gap "A" measures:
 - .045/.050 for 1 disc models
 - .050/.055 for 2 disc models
 - .060/.065 for 3 disc models

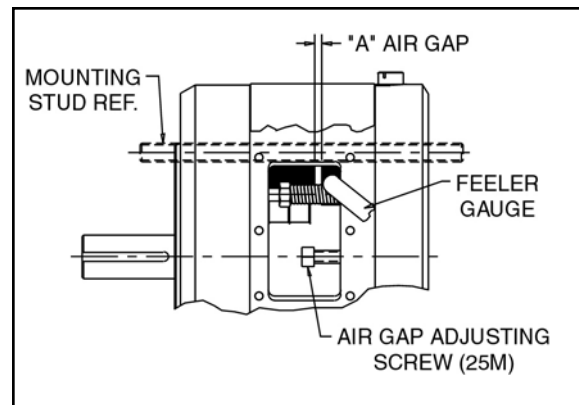

Torque Adjustment

Caution: Load to be removed or blocked. Brake may be inoperative during this procedure.

The magnetic disc brake is factory set for rated static torque. The brake can be adjusted to reduce torque which increases stopping time. Do not attempt to adjust brake for higher torque, as this will cause premature coil burnout.

Refer to Figure 3.

1. To adjust, remove access window cap assemblies (9) to expose torque locknuts (25U) which are above torque springs (25G).
2. To increase stopping time and reduce torque, turn both torque locknuts (25U) counterclockwise, increasing spring length. Each full turn reduces torque 7% to 10% depending on the model.

Friction Disc Replacement

Caution: Load to be removed or blocked. Brake will be inoperative during this procedure.

If brake model number has a prefix VO, or VU, see page 8. When total wear on a rotating friction disc (10) reaches 1/16", replace disc:

Refer to Figs. 3 and 10.

Removing operator assembly

1. Disconnect power.
2. Remove any equipment mounted on the brake C face, such as a gear reducer, by removing nuts (30) and lockwashers (29). If no equipment is mounted on brake C face, remove nuts (30) and lockwashers (29).
3. **For two-piece shaft design:** Remove adapter housing (7) which includes shaft (8).

For one-piece shaft design: Remove entire brake from motor C face. Remove retaining ring (13) or (37) from brake shaft (8A). Press shaft (8A) out of ball bearing (12) or (35) in adapter housing (7). A wheel puller using openings on side of adapter housing (7) may be used.

4. Remove operator assembly (25) by removing screws (11) and pivot stud (19). Item 19 has a hex socket in end of stud for removal.

NOTE: Do not loosen nuts (6) on pivot stud (19), or "Pivot Stud Adjustment" on page 6 to quiet the magnet will have to be made again.

5. Replacing the friction disc

For two-piece shaft design:

Remove worn rotating discs (10) and stationary discs (2). Replace worn discs and install new discs in the same order. Install stabilizer clip (23), if furnished, on rotating discs prior to installing.

For one-piece shaft design:

Remove worn rotating discs (10) and stationary discs (2). Lay bracket (1) on a flat surface. Place a 5/16" thick spacer (1"x1", or 2"x2") on flat surface in the center of the brake.

Place shaft (8A) in center of bracket with splined end down. Replace worn discs in the same order. Install stabilizer clip (23), if furnished, on rotating discs prior to

installing.

6. Re-assembly of operator assembly (25)

Turn two screws (25M) counterclockwise five turns. Place operator assembly onto brake bracket (1) and install two screws (11). Replace compression spring (3), bushing (5), washer (6), and pivot stud (19) which has the two nuts (6) in place. Tighten firmly.

7. Readjust magnet air gap "A" as described under "Wear Adjustment" on page 4.
8. Check manual release operation before completing installation. Adjust per "Manual Release Adjustment" on page 7 if required.

9. Completing installation

For two-piece shaft assembly: Reassemble as described under "Installation" (for models with two-piece shaft design).

For one-piece shaft assembly: Place adapter housing (7) over shaft (8A). Press bearing in adapter housing onto shaft by applying pressure to the inner race of the bearing only. NOTE: The 5/16" thick spacer as described in Step 5 must still be in place. Replace retaining ring (13) or (37). Remove four threaded rods (28) or (32) from the motor and complete assembly as described under "Installation" (for models with one-piece shaft design).

Magnet Assembly Replacement

Caution: Load to be removed or blocked. Brake will be inoperative during this procedure.

Refer to Figs. 3, 5 and 10.

1. Disconnect power supply.
2. Remove adapter assembly as described under "Friction Disc Replacement" at left.
3. Remove two capscrews (25D), wire clamps (25E), magnet assembly (25A) and shock mount (25C).
4. Replace shock mount and magnet, feeding coil wires through hole in back of bracket (25B) as shown in Fig. 5. Tighten mounting screws with 55 to 60 lb. in. torque.
5. Set air gap "A" as described under "Wear Adjustment" on page 4.
6. Energize coil. Magnet should be quiet; if not, refer to "Pivot Stud Adjustment" on page 6.
7. Check manual release. If it does not operate properly, adjust as outlined under "Manual Release Adjustment" on page 6.
8. Reassemble as described under "Friction Disc Replacement" and "Installation" on page 2.

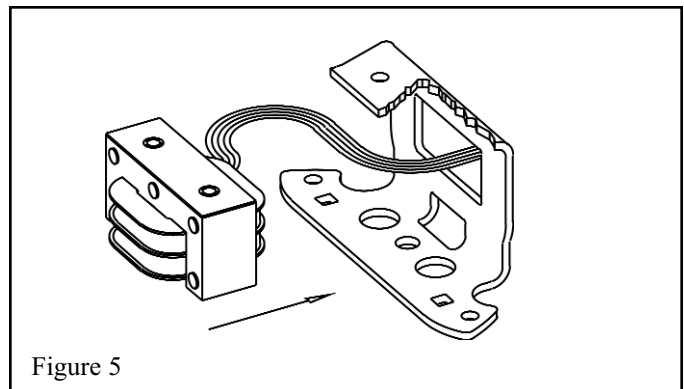

Figure 5

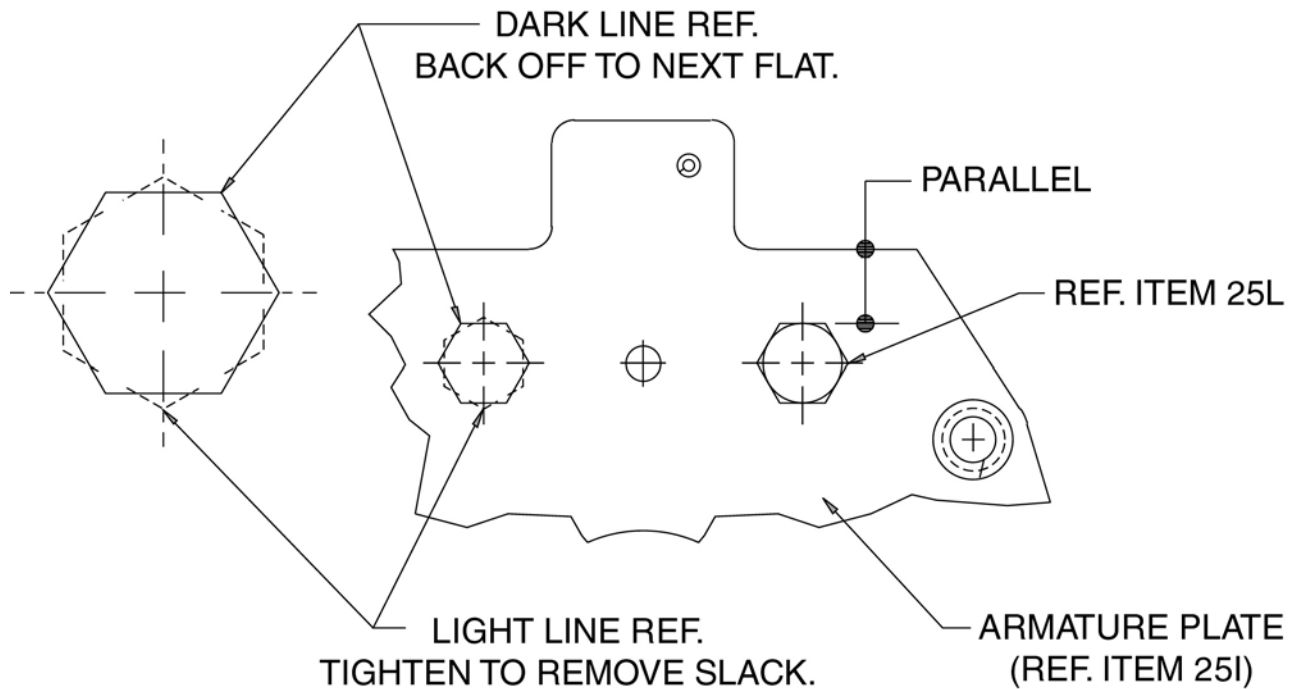

Figure 6

Armature Plate Assembly Replacement

Caution: Load to be removed or blocked. Brake *will* be inoperative during this procedure.

Refer to Figs. 3, 6 and 10.

If you replace the magnet assembly, it may be necessary to replace the armature (25J). If it is badly deformed, it will be difficult to make the magnet quiet.

1. To replace, remove operator assembly (25) from brake. See "Friction Disc Replacement Steps 1-4."
Remove nuts (25U), springs (25G), and carriage bolts (25F). This will allow the armature plate to be removed from magnet bracket.
2. Remove screws (25S), lockwasher (25R), locking plate (25Q), two screws (25L), spacers (25N), and armature (25J). Inspect these parts and shock mount (25P). If worn, replace them also.
3. Put armature in place (ground side up) and install spacers (25N) and screws (25L).
NOTE: Screws (25L) should be tightened to remove slack only. Then back off, counterclockwise on screw so that the next flat on screw is parallel with edge of the armature plate (25I). See Fig. 6.
4. Reassemble to magnet bracket (25B) using items (25U), (25G), and (25F). Reassemble operator assembly to brake bracket. Set magnet air gap "A" and set torque springs (25G) to 1" as shown in Fig. 3.

Pivot Stud Adjustment

Caution: Load to be removed or blocked. Brake *will* be inoperative during this procedure.

Refer to Fig. 6.

This adjustment is made at the factory and may be required when replacing the magnet assembly (25A) or the armature (25J).

The purpose is to adjust the height of the armature plate (25I) so that the armature (25J) is parallel to the magnet (25A) when the brake is energized. This is required so that the magnet will be quiet.

NOTE: Adapter housing (7) must be removed to make this adjustment.

1. To adjust: Hold the nut (6) which is adjacent to washer (4) and loosen the other nut (6) and remove it from the stud.
2. Energize the magnet and slowly tighten remaining nut (6) counterclockwise slowly until the magnet becomes noisy. Turn magnet on and off several times until you find the position where the magnet first becomes quiet. At this point turn nut (6) 1/3 turn (two flats) in a clockwise position. Hold nut in this position and turn magnet on and off to make sure the magnet does not become noisy.
3. Holding this nut in place, screw on other nut and tighten it against the nut you are holding. Tighten firmly.
4. Operate the manual release. If the release does not operate properly, see "Manual Release Adjustment" on next page.

Manual Release Assembly

Refer to Fig. 7.

1. Adapter housing (7) must be removed to replace manual release assembly. Remove adapter housing (7) per “Friction Disc Replacement Steps 1-4” on page 5.
2. Place a small amount of high temperature Neverseize grease around o-ring (40) located on release knob (15) and in release hole located at the top of bracket (1).
3. Place shaft of release knob (15) through hole in bracket (1).
4. Slide return spring (16) over shaft; straight leg of spring should enter shaft first with leg in the position shown.
5. Slip spring (18) over screw (17) and install in tapped hole in release shaft. Screw in until it stops. Make sure spring (16) is not caught under spring (18).
6. Engage bent end of spring (16) over spring (18) as shown. Pull it over with a needle nose pliers or screwdriver.
7. Adjust release per “Manual Release Adjustment” section at right.
8. Reassemble per “Friction Disc Replacement Step 9” on page 5.

Manual Release Adjustment

Caution: Load to be removed or blocked. Brake will be inoperative during this procedure.

Refer to Figs. 3, 7 and 10.

The manual release (15) may require adjustment after replacing the operator assembly (25), magnet (25A), or armature (25J). It also may be required if adjustments are made on the pivot stud nuts (6).

The release is working properly if:

- a) You turn release knob (15) clockwise to stop and the brake is released;
- b) The release knob returns to its normal position automatically when power is applied to the magnet.

NOTE: Adapter housing (7) must be removed to make this adjustment.

1. To adjust: Set air gap “A” as described under “Wear Adjustment” on page 4.
2. If the brake does not release, turn adjusting screw (17) counterclockwise 1/4 turn and try again.
3. If the release knob (15) does not return to its normal position automatically, turn screw (17) clockwise 1/4 turn and try again.

NOTE: You may have to repeat Steps 2 or 3 to get the release to operate properly.

It is important that the release knob returns to its normal position automatically when power is applied to the magnet.

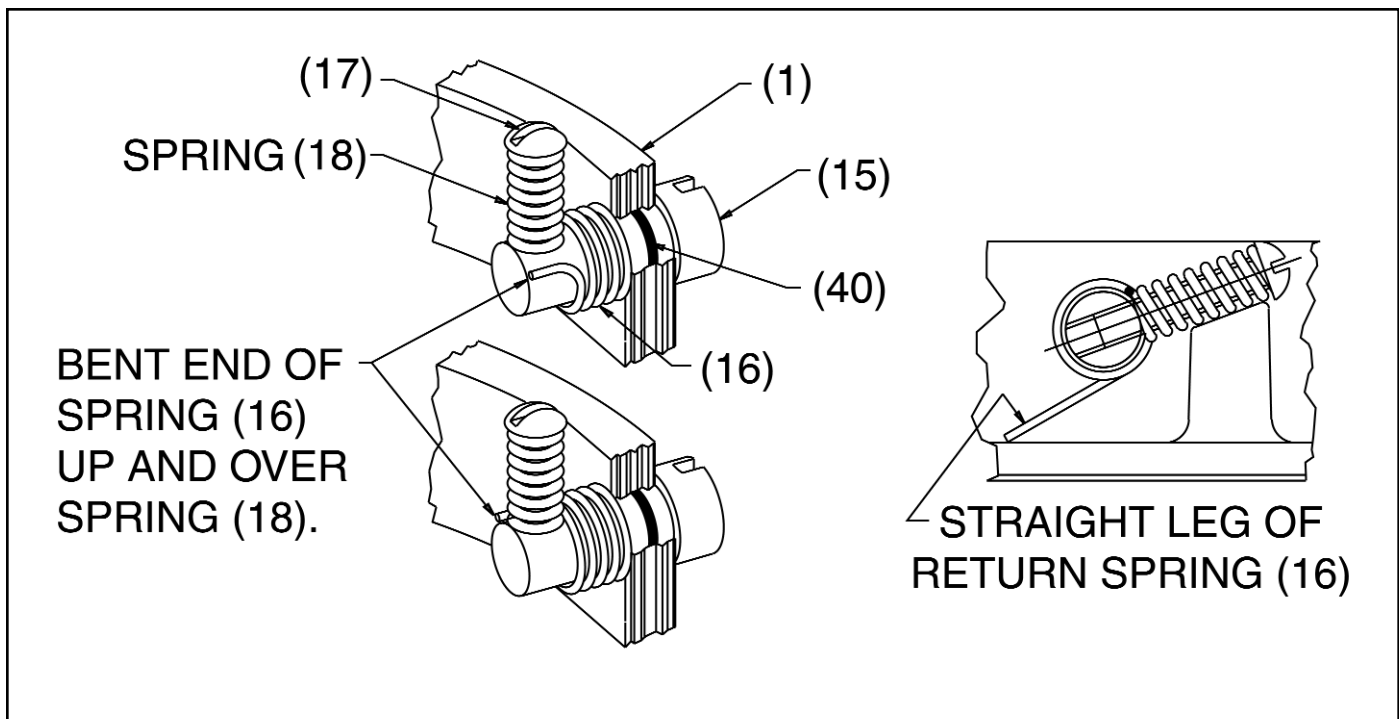

Figure 7

VERTICAL MOUNTING

Installation and Adjustment

Installation and adjustment of the vertically mounted brake is the same as on the standard model.

Friction Disc Replacement

When replacing friction discs, follow procedure outlined on page 5 with this addition:

Care must be taken to insure proper insertion of disc separating springs. Springs are color coded for easy identification, and reference is made to spring color (see Fig. 8 and 9). Since the installation order of the disc springs is dependent on brake mounting position (above or below motor), it is important to consult the correct diagram for spring location.

Item No.	Description	Part No.	Qty. of Parts (determined by no. of rotating discs)		
			1	2	3
1	Spring (silver)	G060350-001	2	2	2
2	Spring (black)	G060350-002	-	2	2
3	Spring (bronze)	G060350-003	-	-	2
4	Roll pin - 1/8" x 5/8"	W005003-071	2	-	-
5	Roll pin - 1/8" x 1"	W005003-077	-	2	-
6	Roll pin - 1/8" x 1-3/8"	W005003-080	-	-	2
7	Stationary disc	H060203-003	1	1	1
8	Stationary disc	H060203-004	1	2	3
9	Adapter housing with drain for Models VU4-60000-5153 only (not shown)	L060393-004	1	1	1

Figure 8 Parts for Vertical Mounting

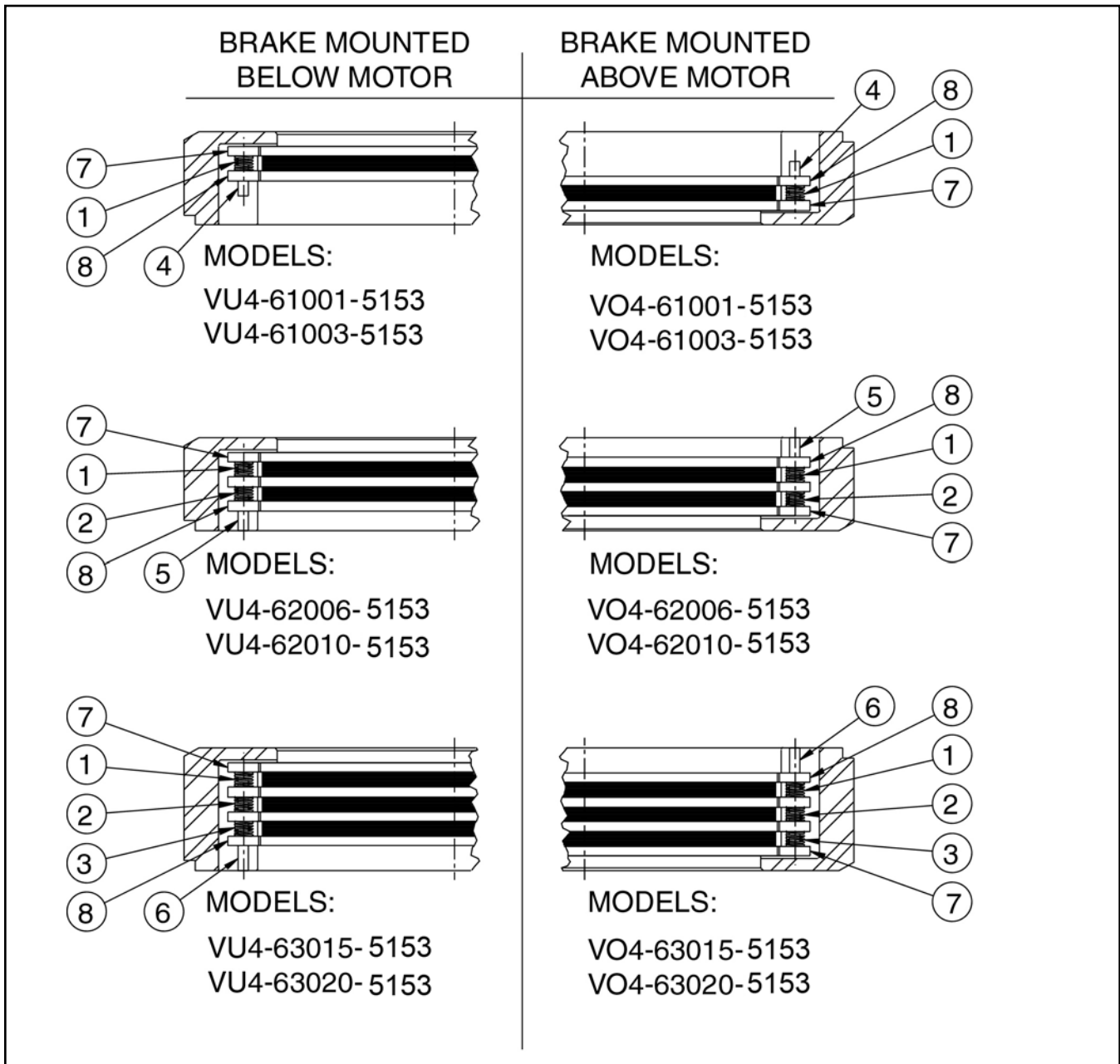

Figure 9

SYMPTOM	POSSIBLE CAUSE	CORRECTIVE ACTION
Brake does not release	<ol style="list-style-type: none"> 1. Broken or damaged parts 2. Wrong voltage 3. Burned out coil 4. Incorrect wiring connections or broken wires 	<ol style="list-style-type: none"> 1. Replace. 2. Check for correct voltage. Voltage must correspond to that listed on brake nameplate. If the voltage is more than 10% below the nameplate voltage, the magnet may not pull in. 3. Replace magnet assembly (25A). 4. Find the connection or wiring fault. Correct or repair as required.
Brake does not stop properly	<ol style="list-style-type: none"> 1. Broken or damaged parts 2. Worn friction disc 3. Hub positioned incorrectly (models with two-piece shaft and hub only) 4. Brake is manually released 	<ol style="list-style-type: none"> 1. Replace. 2. Replace disc if worn to 1/8" thickness. If disc replacement is not required, adjust air gap. (Refer to "Wear Adjustment" section.) 3. Locate hub (22) and key (33), if required. (Refer to "Installation" section.) 4. Determine if manual release is in normal position.
Brake chatters or hums	<ol style="list-style-type: none"> 1. Dirty magnet faces 2. Magnet faces are not parallel in closed position 3. Loose or broken shading coil 4. Wrong voltage supply 	<ol style="list-style-type: none"> 1. To remove dirt, insert a clean sheet of paper between faces and energize brake. Move paper around between faces to dislodge dirt, then remove paper. 2. See "Pivot Stud Adjustment" section. 3. Replace magnet assembly (25A). 4. Check for low voltage.
Manual release does not work	<ol style="list-style-type: none"> 1. Broken or damaged parts 2. Improper setting 	<ol style="list-style-type: none"> 1. Replace 2. See "Manual Release Adjustment" section.

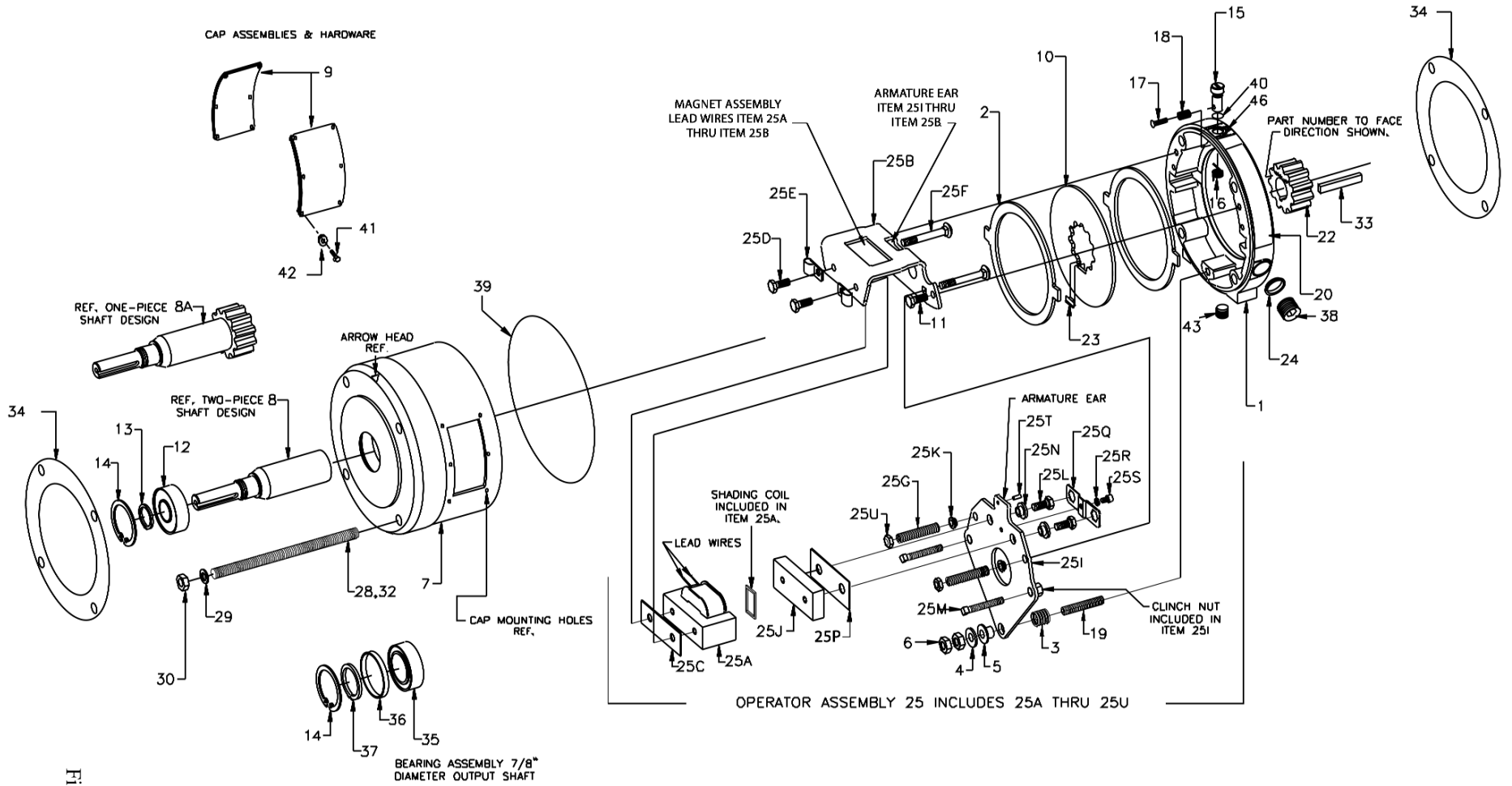

Figure 10

REPLACEMENT PARTS LIST

Item No.	Description	Encl. Housing 4-60000-5153	Qty.
1	Bracket 1 & 2 disc	L060256-001	1
1	Bracket 3 disc	L060257-001	1
2	Stationary disc	H060147-001	*
3	Compression spring for all except 20 lb. ft.	G060821-001	1
3	Copmression spring, 20 lb. ft.	G060852-001	1
4	Plain brass washer	W004003-024	1
5	Nylon bushing	G060820-001	1
6	Hex nut 5/16-18 thread	W003002-002E	2
7	Adapter housing	L060393-005	1
8	Two-piece shaft design	**	1
8A	One-piece shaft design	**	1
9	Cap assembly, stainless steel	H060658-004	1
10	Splined rotating friction disc	H060157-005	*
11	Hex. Hd. Capscrew 1/4-20 x 1/2 lg.	W001008-001E	2
12	Double seal ball bearing, 5/8 or 3/4 output shaft	W009001-001	1
13	Truarc retaining ring, 5/8 or 3/4 output shaft	W006007-001	1
14	Truarc retaining ring, all models	W006002-001	1
15	Release knob	G060848-001	1
16	Release return spring	G060881-001	1
17	Release adjustment screw	W001002-056C	1
18	Release adjustment lock spring	G060795-001	1
19	Pivot stud	W002005-303A	1
20	Nameplate	K060507-001	1
21	Instruction label, 2-piece shaft design	K060492-001	1
21	Instruction label, 1-piece shaft design	K060493-001	1
22	Splined hub for use with item 8	**	1
23	Stabilizer clip, rotating friction disc (when used)	H060466-001	*
24	Wire outlet cap plug	W008003-001	1
25	Operator assembly: includes "A" through "U" (not shown as assembly)	K060463-**	1
25A	Magnet assembly	**	1
25B	Magnet mounting bracket	H060544-001	1
25C	Magnet shock mount	G060813-001	1
25D	Hex. Hd. Capscrew 1/4-20 x 5/8 lg. Grade 5	W001007-0002E	2
25E	Cable clamp	W021003-001	2
25F	Carriage bolts 1/4-20	G060803-001	2
25G	Torque spring (blue) 1.5 lb. ft.	G060791-001	2
25G	Torque spring (silver) 3 & 6 lb. ft.	G060792-001	2
25G	Torque spring (bronze) 10 & 15 lb. ft.	G060793-001	2
25G	Torque spring (green) 20 lb. ft.	G060794-001	2

Item No.	Description	Encl. Housing 4-60000-5153	Qty.
25H	Armature plate assembly: includes "T" through "T" (not shown as an assem.)	H060541-**	1
25I	Armature plate	H060545-003	1
25J	Armature lamination assembly	G060788-001	1
25K	Nyliner bushing	W013005-001	2
25L	Hex. Hd. Capscrew 1/4-20 x 5/8 lg.	W001007-002E	2
25M	Wear adjustment screw sq. hd.	W002003-001	2
25N	Armature spacer	G060798-002	2
25P	Armature shock mount	G060808-003	1
25Q	Locking plate	G060812-001	1
25R	Split spring lockwasher #8	W004006-003	1
25S	Soc. Hd. Capscrew	W001013-201	1
25T	Roll pin 5/32" dia. X 3/8" lg.	W005003-098	1
25U	Locknut 1/4-20	W003013-001	2
26	Hardware bag includes 29 thru 31 1 & 2 disc models (not shown)	H060237-112	1
27	Hardware bag includes 29 thru 32 3 disc models (not shown)	H060237-113	1
28	Mounting stud 1 & 2 disc only	W012001-001	4
29	3/8 split spring lockwasher	W004006-008	4
30	Hex nut 3/8-16	W003002-003	4
31	Operating instructions & parts manual (not shown)	G061031-001	1
32	Mounting stud	W012001-002	4
33	Key 3/16 sq. x 1-13/16 lg.	W007001-017	1
34	Mounting face gasket	H060344-003	2
35	Double seal ball bearing, 7/8 shaft	W009001-009	1
36	Bearing spacer	G060531-001	1
37	Truarc retaining ring, 7/8 shaft	W006007-002	1
38	Pipe plug 1/2"	W001002-004A	1
39	"O" ring, adapter housing, buna-n	W006001-019	1
40	"O" ring release rod, buna-n	W006001-025	1
41	Hex hd. Capscrew, #8-32, SS	W001007-151C	2
42	#8 sealing washer	W011011-002C	2
43	1/8" hex. Soc. Pipe plug	W010002-001A	1
44	Key attaching label (not shown)	G060648-001	1

*The number of rotating discs is shown in the brake model number. Example 4-62006-5153 has two rotating discs. The number of stabilizing clips is the same as rotating discs. The number of stationary discs is one more than the number of rotating discs.

** Part number is determined by one or more of the following: model number, voltage, motor shaft diameter and keyway size.

SPECIFICATIONS

Torque: 1-1/2 through 20 lb. ft.

NEMA Motor Frame Sizes: 56C, 143TC, and 145TC.

Enclosure: Aluminum with steel wrap cover

Voltage: All NEMA single phase voltages and frequencies are standard. Others optional.

Duty: Rated for continuous duty.

Mounting: Direct to NEMA C face, with one additional C face for mounting of equipment to brake. Horizontal or vertical position with slight modifications.

Maximum Ambient Temperature: 40°C.

Maximum Input Speed: 3600 RPM

Certification:

Models 4-60000-5153 are certified CSA Enclosure 4.

ORDERING INFORMATION

Replacement parts can be purchased from your local distributor or from Dings Co. at the address and phone number shown on the last page. The name of the Dings distributor or sales representative in your area can be obtained by calling the Dings Co. or online at www.dingsco.com.

For replacement parts, please furnish this data with your order:

- Brake model number
- Description (refer to Parts List)
- If ordering a hub, specify bore diameter and keyway dimensions
- If ordering electrical parts, specify voltage and frequency

For a replacement brake, please furnish this data with your order:

- Brake model number
- Voltage and frequency
- Hub bore and keyway dimensions
- Mounting - horizontal or vertical. If vertical, specify whether above or below motor. If brake includes foot mounting bracket or adapter, specify.

WARRANTY

Seller warrants products manufactured by it and supplied hereunder to be free from defects in materials and workmanship under normal use and proper maintenance for a period of twelve months from date of shipment. If within such period any such products shall be proved to Seller's reasonable satisfaction to be defective, such products shall be repaired or replaced at Seller's option Seller's obligation and Buyer's exclusive remedy hereunder shall be limited to such repair and replacement and shall be conditioned upon Seller's receiving written notice of any alleged defect no later than 10 days after its discovery within the warranty period and, at Seller's option, the return of such products to Seller, f.o.b. its factory, when such return is feasible. Seller reserves the right to satisfy its warranty obligation in full by reimbursing Buyer for all payments it makes hereunder, and Buyer shall thereupon return the products to Seller. Seller shall have the right to remedy such defects. Seller makes no warranty with respect to wear or use items, such as belts, chains, sprockets, discs and coils, all which are sold strictly AS IS.

The foregoing warranties are exclusive and in lieu of all other express and implied warranties (except of title) including but not limited to implied warranties of merchantability, fitness for a particular purpose, performance, or otherwise, and in no event shall the Seller be liable for claims (based upon breach of express or implied warranty, negligence, product liability, or otherwise) for any other damages, whether direct, immediate, incidental, foreseeable, consequential, or special.

