



60 Series End-Mount Brake Instructions Standard Housing

Read carefully before attempting to assemble, install, operate or maintain the product described. Protect yourself and others by observing all safety information. Failure to comply with instructions could result in personal injury and/or property damage! Retain instructions for future reference.



DESCRIPTION

These magnetic disc brakes mount directly onto NEMA 56C, 143TC, and 145TC frame motors, on the end opposite the drive shaft. The brake is direct acting, electro-magnetically released, and spring set. It uses rotating friction and stationary disc contact to supply positive braking action. It retains quick release and setting capabilities at all times.

WARNING: Do not install or use these brakes in an explosive atmosphere.

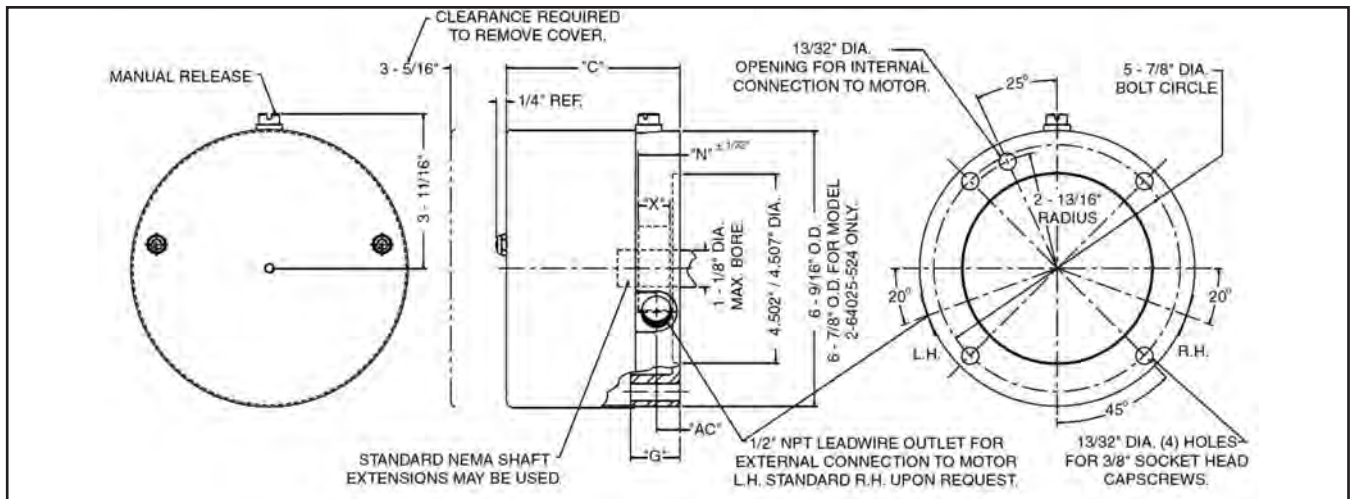

Figure 1

| Model Number | Number of Rotating Discs | Torque lb-ft | *Thermal Capacity HPS/Min | Inertia of Rotating Parts lb-ft ² | Dimensions | | | | |
|--------------|--------------------------|--------------|---------------------------|--|------------|------|------|------|------|
| | | | | | X | G | AC | C | N |
| 61001-524 | 1 | 1.5 | 6 | 0.006 | 0.88 | 1.19 | 0.59 | 4.13 | 1.13 |
| 61003-524 | 1 | 3 | 6 | 0.006 | 0.88 | 1.19 | 0.59 | 4.13 | 1.13 |
| 61006-524 | 1 | 6 | 6 | 0.006 | 0.88 | 1.19 | 0.59 | 4.13 | 1.13 |
| 62006-524 | 2 | 6 | 6 | 0.010 | 0.88 | 1.19 | 0.59 | 4.13 | 1.13 |
| 62010-524 | 2 | 10 | 6 | 0.010 | 0.88 | 1.19 | 0.59 | 4.13 | 1.13 |
| 62015-524 | 2 | 15 | 6 | 0.010 | 0.88 | 1.19 | 0.59 | 4.13 | 1.13 |
| 63010-524 | 3 | 10 | 6 | 0.015 | 1.19 | 1.56 | 0.96 | 4.50 | 1.44 |
| 63015-524 | 3 | 15 | 6 | 0.015 | 1.19 | 1.56 | 0.96 | 4.50 | 1.44 |
| 63020-524 | 3 | 20 | 6 | 0.015 | 1.19 | 1.56 | 0.96 | 4.50 | 1.44 |
| 63025-524 | 3 | 25 | 6 | 0.015 | 1.19 | 1.56 | 0.96 | 4.50 | 1.44 |
| 64025-524 | 4 | 25 | 6 | 0.020 | 1.34 | 2.25 | 1.56 | 5.19 | 2.00 |

*Thermal capacity (HPS/MIN.) was determined under the following test conditions: a) Room temperature 72°F. b) Stopping time of one second or less. c) Brake mounted in a horizontal position. d) Equal on and off times. e) 1800 RPM f) Coil energized with 110% of rated voltage.

WARNING:

Brake performance and features must be carefully matched to the requirements of the application.

Consideration must be given to torque requirements, especially where an overhauling condition exists, as well as thermal capacity, ambient temperature, atmospheric explosion hazards, type of enclosure and any other unusual conditions.

Improper selection and installation of a brake and/or lack of maintenance may cause brake failure which could result in damage to property and/or injury to personnel.

If injury to personnel could be caused by brake failure, additional means must be provided to insure safety of personnel.

UNPACKING

When unpacking the brake, inspect it carefully for damage that may have occurred during transit.

GENERAL SAFETY INFORMATION

NOTE: These brakes are not intended for accurate positioning applications. They are designed for applications that require rapid stopping and holding power, such as on conveyors, door openers, etc.

1. For applications with high inertia-type loads or rapid cycling, the thermal capacity of the brake must be considered.
2. Observe all local electrical and safety codes, as well as the National Electrical Code (NEC) and the Occupational Safety and Health Act (OSHA).
3. Brake motors and brake gearmotors must be securely and adequately grounded. This can be accomplished by wiring with a grounded metal-clad raceway system, by using a separate ground wire connected to the bare metal of the motor frame, or other suitable means. Refer to NEC Article 250 (Grounding) for additional information. All wiring should be done by a qualified electrician.
4. Always disconnect power before working on or near a brake motor, a brake gearmotor, or its connected load. If the power disconnect point is out of sight, lock it in the open position and tag it to prevent unexpected application of power.
5. When working on the brake, be sure the load is completely removed, secured or blocked to prevent injury or property damage.
6. Provide guarding for all moving parts.
7. Be careful when touching the exterior of an operating motor, gearmotor or brake. It may be hot enough to cause injury or to be painful. This condition is normal for modern motors, which operate at higher temperatures when running at rated load and voltage.
8. Protect all electrical lead wires and power cables against contact with sharp objects or moving parts.
9. Do not kink electrical lead wires and power cables, and never allow them to touch oil, grease, hot surfaces, or chemicals.

INSTALLATION

CAUTION: To preserve pre-alignment of rotating discs for ease of installation, do not operate manual release or energize brake coil before installation.

NOTE: The brakes are designed for horizontal mounting. Modification is required for vertical mounting. Brakes that are modified will have a prefix on the model number of VO (Vertical Over) or VU (Vertical Under).

Numbers in parentheses refer to parts illustrated in Figs. 3, 5, 6 and 9.

Mounting Hub on Motor Shaft

1. Remove hub (1) from brake and position it on motor shaft with key as shown in Fig. 1. Stamped part number on hub should face away from motor. Tighten hub setscrews with 8 to 10 lb-ft torque.

Placing Brake on Motor Shaft

1. Remove two cover locknuts (22) and cover (20). Position brake over hub on shaft, aligning hub splines with rotating disc splines.
2. Bolt brake to motor flange with four 3/8 - 16 socket head capscrews.
NOTE: Dimension "G" (Fig. 1) is the length of the mounting hole through brake bracket.
3. Place coil lead wires around mounting bracket (15C) to the same side as the desired wire outlet position. Connect lead wires per "Connection of Coil Leads" and Fig. 2.
4. Replace cover (20) and cover locknuts (22). Tighten just enough to hold the cover in place.

Wiring Diagrams

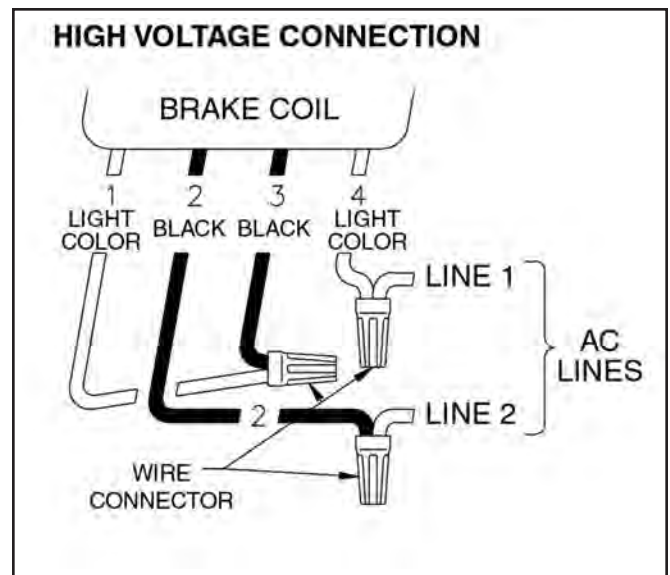
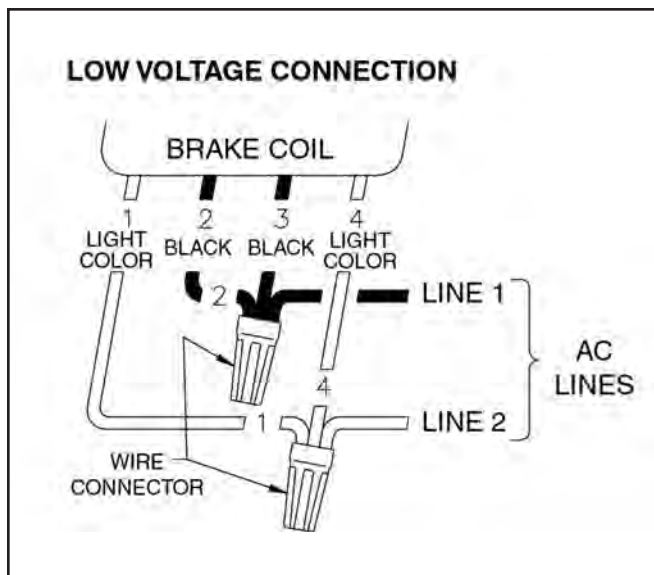

Figure 2

Connection of Coil Leads

After securing the brake to the motor, connect coil leads for proper voltage per wiring diagram (Fig. 2 shows dual voltage coil). Incorrect connection can result in brake failure.

CAUTION: The voltage supplied to the coil must match the voltage that the coils are connected for, or the coils will burn out.

Single voltage coil:

Connect brake coil leads to any two line leads (single or three phase) of same voltage and frequency as brake.

Dual voltage coil:

Connect leads 2 and 4 to any two motor line leads (single or three phase) of same voltage as brake. Connect leads 1 and 3 as shown for voltage desired. Brake must be energized with motor.

OPERATION

These brakes are spring set devices with an electrical (magnet) release. They contain a rotating friction disc which is driven by a hub mounted on the motor shaft. When energized, the magnet compresses the torque springs, removing the force pressing the stationary disc and friction disc together. This permits free rotation of the shaft.

WARNING: Observe proper safety precautions in applications where a brake failure would allow the load to move in such a manner as to injure personnel. KEEP PERSONNEL AWAY FROM LOAD AREAS.

If brake torque rating is higher than motor full-load torque rating, use brake rating rather than motor rating when selecting other drive components.

Take the following precautions when operating the brake:

1. Do not operate the brake at higher than normal static torque capacity.
2. For applications with high inertia-type loads or rapid cycling, the thermal capacity of the brake must be considered.
3. High start-stop rates may damage motor. Consult motor manufacturer if high cycling rates are expected.
4. Be sure power supply conforms to electrical rating of brake.

Manual Release

The brake is equipped with a manual release. Turn the release knob (3) clockwise to stop position to release the brake. The brake will remain released until the release knob is turned counterclockwise (approx. 65°) or until the brake coil is energized, automatically resetting the brake.

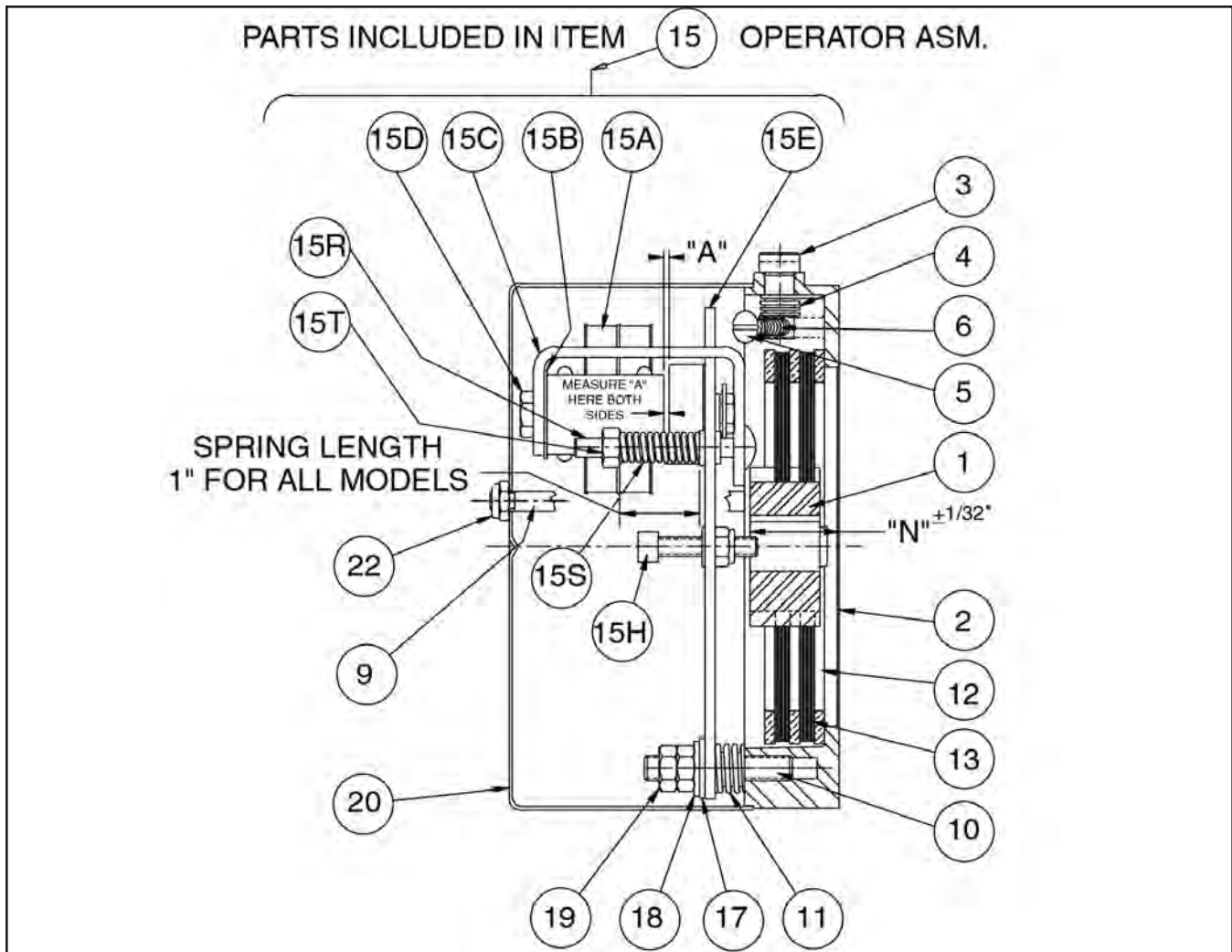

Figure 3

MAINTENANCE

CAUTION: Before attempting to service or remove any components, make certain that the power is disconnected and that the load is completely removed, secured or blocked to prevent injury or property damage.

Wear Adjustment

CAUTION: Load to be removed or blocked. Brake may be inoperative during this procedure.

Before air gap "A" reaches .100", adjustment is required. Any delay in adjusting the magnet air gap will result in eventual loss of torque. Refer to Fig. 3.

1. To adjust, remove cover locknuts (22) and cover (20) to expose square head wear adjusting screws (15H) and expose magnet air gap "A".

2. Measure air gap "A" using 3/8" to 1/2" wide feeler gauge. (Measure at center of magnet.)
3. Turn two square head adjusting screws (15H) until air gap "A" measures:
 - .045/.050 for 1 disc models
 - .050/.055 for 2 disc models
 - .060/.065 for 3 disc models
 - .060/.065 for 4 disc models
 Air gap should be the same on both sides.

Torque Adjustment

Caution: Load to be removed or blocked. Brake may be inoperative during this procedure.

The magnetic disc brake is factory set for rated static torque. The brake can be adjusted to reduce torque which increases stopping time. Do not attempt to adjust brake for higher torque, as this will cause premature coil burnout. (Refer to Fig. 3)

1. To adjust, remove cover locknuts (22) and cover (20) to expose torque locknuts (15T), which are above torque springs (15S).
2. To increase stopping time and reduce torque, turn two locknuts (15T) counterclockwise, increasing spring length. Each full turn reduces torque 7% to 10% depending upon the model.

Friction Disc Replacement

Caution: Load to be removed or blocked. Brake will be inoperative during this procedure.

If brake model number has a prefix VO or VU, see page 8.

When total wear on a rotating friction disc (13) reaches 1/16", replace disc:

1. **Removing operator assembly**

Disconnect power.

2. Remove cover locknuts (22) and cover (20).
3. Remove operator assembly (15) by removing screws (16), pivot stud (10), washer (18), bushing (17), and spring (11).

NOTE: Item (10) has a hex socket in end of stud for removal. Do not loosen nuts (19) on pivot stud (10), or "Pivot Stud Adjustment" (on page 6) to quiet the magnet will have to be made.

4. **Replacing the friction disc**

Remove worn rotating discs (13) and stationary discs (12). Replace worn discs and install new discs in the same order. Install stabilizer clip (14), if furnished, on rotating discs prior to installing.

5. **Re-assembly of operator assembly (15)**

Refer to Figs. 3 and 9. (Capscrew (16) is shown in Fig. 9 and not Fig. 3)

Turn two screws (15H) counterclockwise five turns. Place operator assembly onto brake bracket (2) and install two screws (16). Replace compression spring (11), bushing (17), washer (18), and pivot stud (10) which has the two nuts (19) in place. Tighten firmly.

6. Readjust magnet air gap "A" as described under "Wear Adjustment" on page 4.
7. Check manual release operation before completing installation. Adjust per "Manual Release Adjustment" on page 7 if required.

8. **Completing installation**

Replace cover (20) and cover locknuts (22). Tighten just enough to hold the cover in place. Reconnect power.

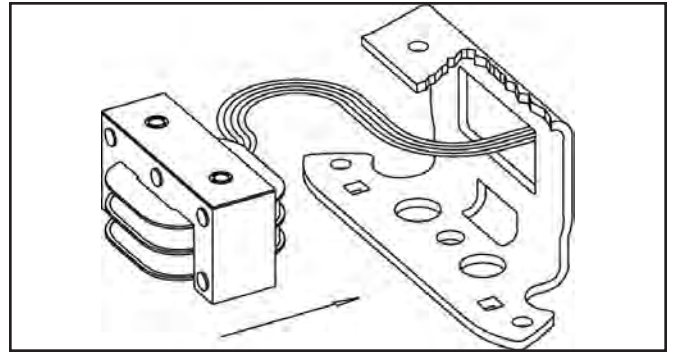

Figure 4

Magnet Assembly Replacement

Caution: Load to be removed or blocked. Brake will be inoperative during this procedure.

1. Disconnect power supply.
2. Remove cover locknuts (22) and cover (20).
3. Remove two capscrews (15D), magnet assembly (15A) and shock mount (15B).
4. Replace with new magnet assembly (15A), making sure shock mount (15B) is in place. Feed coil lead wires through hole in back of bracket (15C) as shown in Fig. 4. Tighten mounting screws (15D) with 55-60 lb. in. torque.
5. Place coil lead wires around mounting bracket (15C) to the same side as the wire outlet position. Connect coil lead wires per "Connection of Coil Leads" and Fig. 2.
6. Set air gap "A" as described under "Wear Adjustment" on page 4.
7. Energize coil. Magnet should be quiet; if not, refer to "Pivot Stud Adjustment" on page 6.
8. Check manual release. If it does not operate properly, adjust as outlined under "Manual Release Adjustment" on page 7.
9. Replace cover (20) and cover locknuts (22). Tighten just enough to hold the cover in place. Reconnect power.

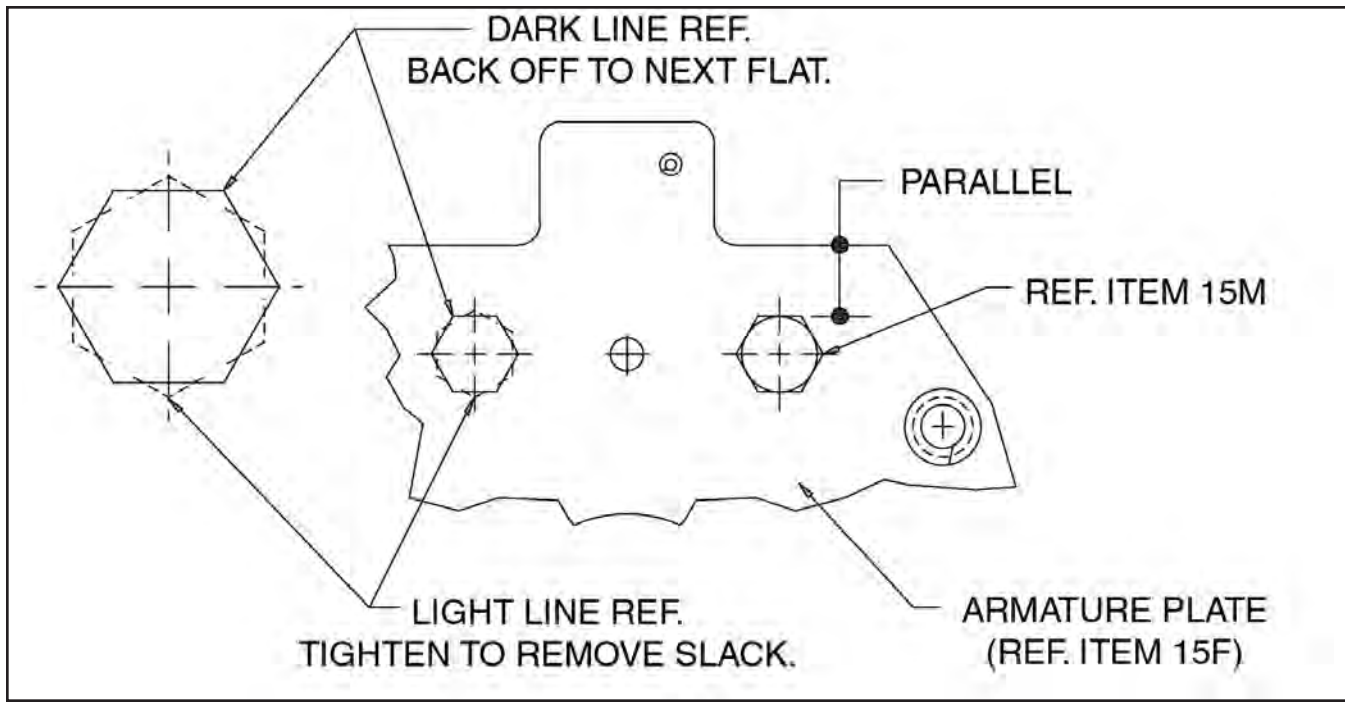

Figure 5

Armature Replacement

CAUTION: Load to be removed or blocked. Brake will be inoperative during this procedure.

If you replace the magnet assembly, it may be necessary to replace the armature (15J). If it is badly deformed, it will be difficult to make the magnet quiet.

1. To replace, remove operator assembly (15) from brake. See "Friction Disc Replacement Steps 1-3" on page 5.
Remove nuts (15T), springs (15S) and carriage bolts (15R). This will allow the armature plate assembly to be removed from magnet bracket.
2. Remove screw (15Q), lockwasher (15P), locking plate (15N), two screws (15M), spacers (15L), and armature (15J). Inspect these parts and shock mount (15K). If worn, replace them also.
3. Put armature in place (ground side up) and install spacers (15L) and screws (15M).

NOTE: See Fig. 5 Screws (15M) should be tightened to remove slack only. Then back off, counterclockwise on screw so that the next flat on screw is parallel with edge of the armature plate (15F).

Install locking plate (15N), screw (15Q), and lockwasher (15P). Tighten screw with 30 lb-in torque.

4. Reassemble to magnet bracket (15C) using items (15R), (15S) and (15T). Reassemble operator assembly to brake bracket. Set magnet air gap "A" and set torque springs (15S) to 1" as shown in Fig. 3.

Pivot Stud Adjustment

CAUTION: Load to be removed or blocked. Brake will be inoperative during this procedure.

This adjustment is made at the factory and may be required when replacing the magnet assembly (15A) or the armature (15J).

The purpose is to regulate the height of the armature plate (15F) so that when the magnet (15A) is energized, the armature (15J) is parallel with it. This is required so that the magnet will be quiet.

NOTE: Cover (20) must be removed to make this adjustment.

1. To adjust: Hold nut (19) which is adjacent to washer (18) and loosen the other nut (19) and remove it from the stud.
2. Energize the magnet and turn remaining nut (19) counterclockwise slowly until the magnet becomes noisy. Turn magnet on and off several times until you find the position where the magnet first becomes quiet.
At this point, turn nut (19) 1/3 turn (two flats) in a clockwise position. Hold nut in this position and turn magnet on and off to make sure the magnet does not become noisy.
3. Holding this nut in place, screw on other nut and tighten it against the nut you are holding to 11-13 lb-ft of torque.
4. Operate the manual release. If the release does not operate properly, see "Manual Release Adjustment" on next page.

Manual Release Adjustment

CAUTION: Load to be removed or blocked. Brake will be inoperative during this procedure.

The manual release (3) may require adjustment after replacing the operator assembly (15), magnet (15A0, or armature (15J). It also may be required if adjustments are made on the pivot stud nuts (19).

The release is working properly if:

- a) you turn release knob (3) clockwise to stop and the brake is released;
- b) the release knob returns to its normal position automatically when power is applied to the magnet.

NOTE: Cover (20) must be removed to make this adjustment.

1. To adjust: Set air gap "A" as described under "Wear Adjustment" on page 4.
2. If the brake does not release, turn adjusting screw (5) counterclockwise 1/4 turn and try again.
3. If the release knob (3) does not return to its normal position automatically, turn screw (5) clockwise 1/4 turn and try again.

NOTE: You may have to repeat Steps 2 or 3 to get the release to operate properly.

It is important that the release knob returns to its normal position automatically when power is applied to the magnet.

Manual Release Assembly

Refer to Fig. 6

1. Place shaft of release knob (3) through hole in bracket (2).
2. Slide return spring (4) over shaft; straight leg of spring should enter shaft first with leg in the position shown.
3. Slip spring (6) over screw (5) and install in tapped hole in release shaft. Screw in until it stops.
Make sure spring (4) is not caught under spring (6).
4. Engage bent end of spring (4) over spring (6) as shown. Pull it over with a needle-nose pliers or screwdriver.
5. Adjust release. See "Manual Release Adjustment" on the left.

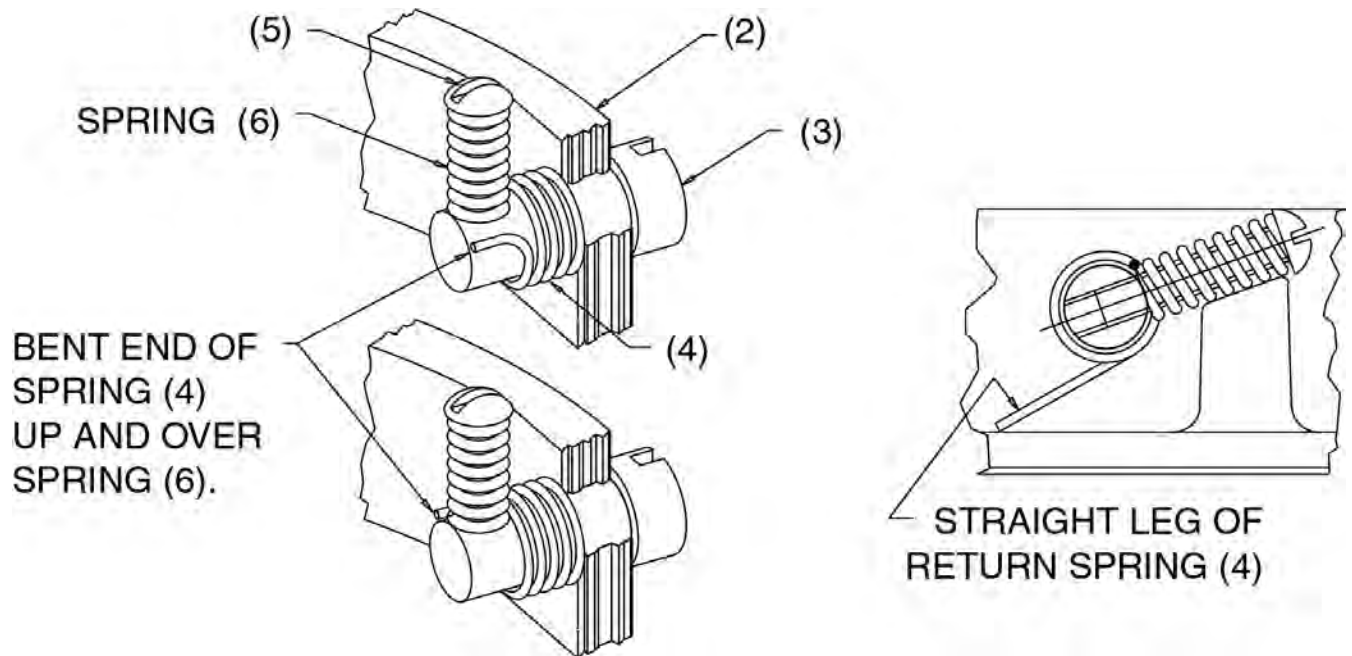

Figure 6

VERTICAL MOUNTING

Installation and adjustment of the vertically mounted brake is the same as on the standard model.

Friction Disc Replacement

When replacing friction discs, follow procedure outlined on page 5 with this addition:

Care must be taken to insure proper insertion of disc separating springs. Springs are color coded for easy identification, and reference is made to spring color (see Figs. 7 and 8). Since the installation order of the disc springs is dependent on brake mounting position (above or below motor), it is important to consult the correct diagram for spring location.

Figure 8

| Item No. | Description | Part No. | Qty. of Parts (determined by no. of rotating discs) | | | |
|----------|---------------------------|-------------|--|---|---|---|
| | | | 1 | 2 | 3 | 4 |
| 1 | Spring (silver) | G060350-001 | 2 | 2 | 2 | - |
| 2 | Spring (black) | G060350-002 | - | 2 | 2 | - |
| 3 | Spring (bronze) | G060350-003 | - | - | 2 | - |
| 4 | Roll pin-1/8" x 5/8" | W005003-071 | 2 | - | - | - |
| 5 | Roll pin-1/8" x 1" | W005003-077 | - | 2 | - | - |
| 6 | Roll pin-1/8" x 1 3/8" | W005003-080 | - | - | 2 | - |
| 7 | Stationary disc | H060203-003 | 1 | 1 | 1 | - |
| 8 | Stationary disc | H060203-004 | 1 | 2 | 3 | 4 |
| 9 | Cast iron bracket (ref.) | - | - | - | - | 1 |
| 10 | Flotation spring (silver) | G060736-001 | - | - | - | 2 |
| 11 | Flotation spring (black) | G060736-002 | - | - | - | 2 |
| 12 | Flotation spring (bronze) | G060736-003 | - | - | - | 2 |
| 13 | Flotation spring (red) | G060736-004 | - | - | - | 2 |
| 14 | Roll pin-1/8" x 1 3/4" | W005003-083 | - | - | - | 2 |

Figure 7 Parts for Vertical Mounting

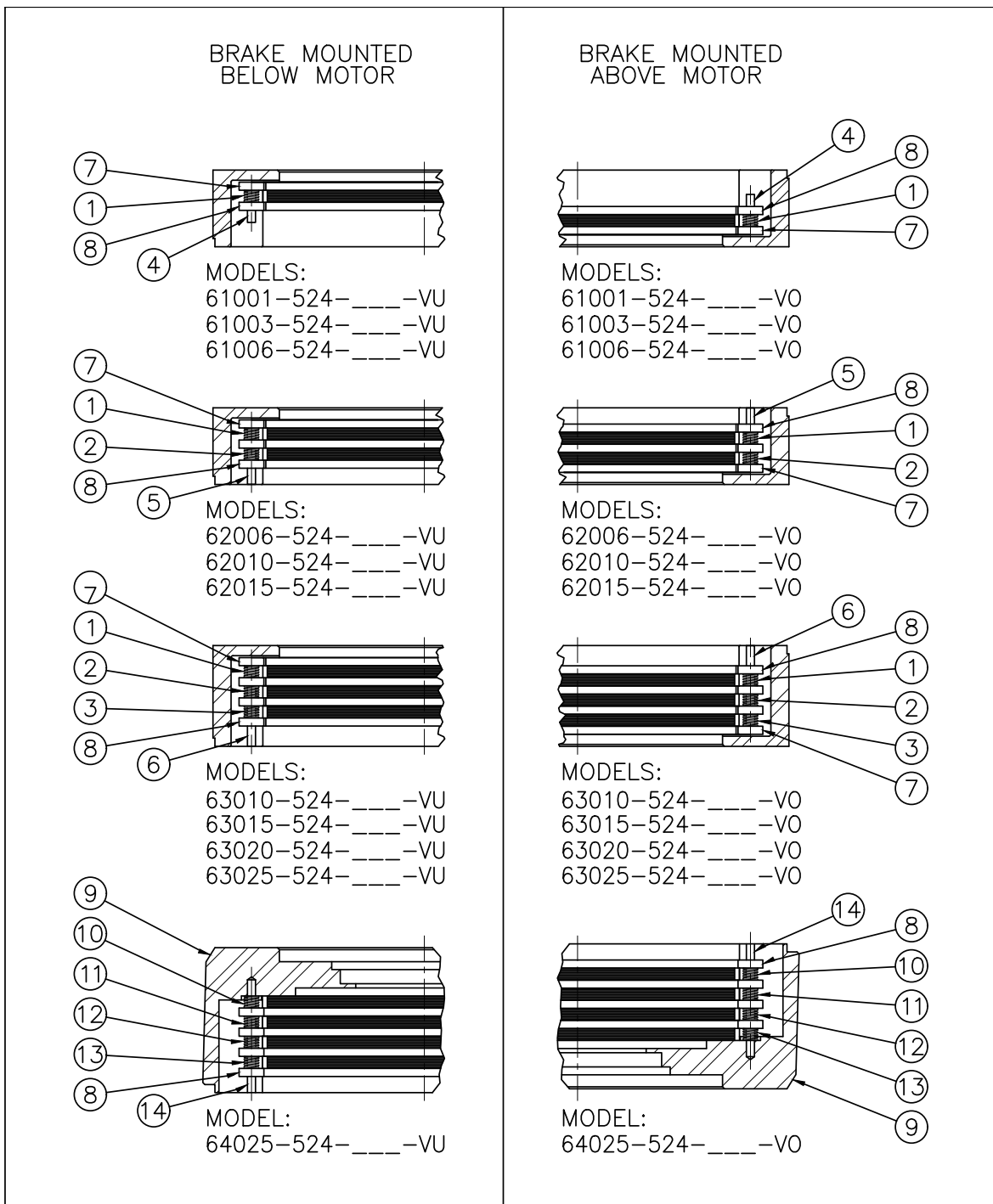

TROUBLESHOOTING CHART

| SYMPTOM | POSSIBLE CAUSE | CORRECTIVE ACTION |
|------------------------------|--|---|
| Brake does not release | <ol style="list-style-type: none"> 1. Broken or damaged parts 2. Wrong voltage 3. Burned out coil 4. Incorrect wiring connections or broken wires | <ol style="list-style-type: none"> 1. Replace. 2. Check for correct voltage. Voltage must correspond to that listed on brake nameplate. If the voltage is more than 10% below the nameplate voltage, the magnet may not pull in. 3. Replace magnet assembly (15A). 4. Find the connection or wiring fault. Correct or repair as required. |
| Brake does not stop properly | <ol style="list-style-type: none"> 1. Broken or damaged parts 2. Worn friction disc 3. Hub positioned incorrectly 4. Brake is manually released | <ol style="list-style-type: none"> 1. Replace. 2. Replace disc if worn to 1/8" thickness. If disc replacement is not required, adjust air gap. (Refer to "Wear Adjustment" section.) 3. Relocate hub (1) and key, if required. (Refer to "Installation" section.) 4. Determine if manual release is in normal position. |
| Brake chatters or hums | <ol style="list-style-type: none"> 1. Dirty magnet faces 2. Magnet faces are not parallel in closed position 3. Loose or broken shading coil 4. Wrong voltage supply | <ol style="list-style-type: none"> 1. To remove dirt, insert a clean sheet of paper between faces and energize brake. Move paper around between faces to dislodge dirt, then remove paper. 2. See "Pivot Stud Adjustment" section. 3. Replace magnet assembly (15A). 4. Check for low voltage. |
| Manual release does not work | <ol style="list-style-type: none"> 1. Broken or damaged parts 2. Improper setting | <ol style="list-style-type: none"> 1. Replace. 2. See "Manual Release Adjustment" section. |

REPLACEMENT PARTS ILLUSTRATION

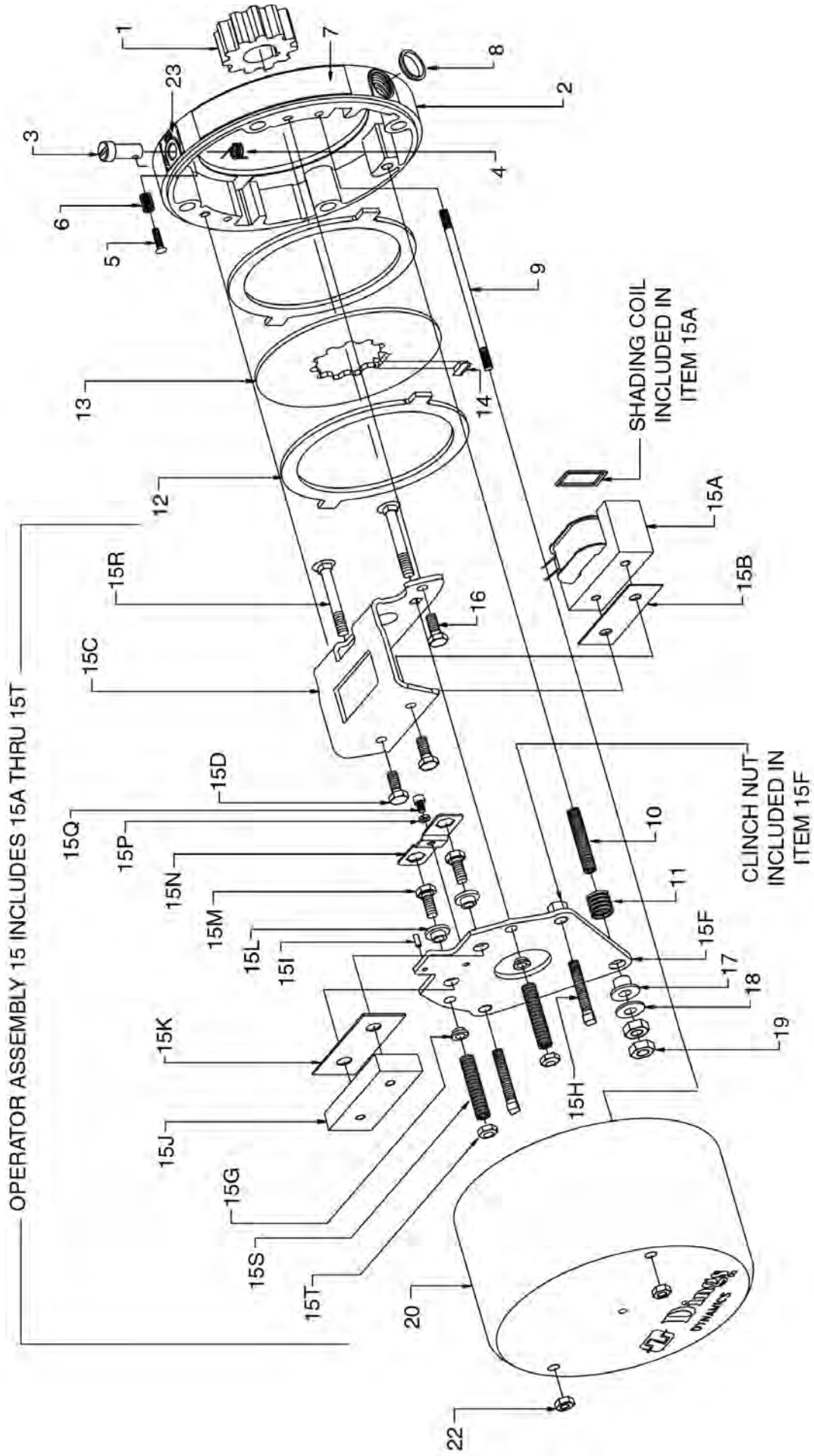

Figure 9

REPLACEMENT PARTS LIST

| Item No. | Description | Part Number | Qty. |
|----------|--|--------------|------|
| 1 | Hub, splined | K060107-*** | 1 |
| 2 | Bracket, 1 & 2 disc models (aluminum) | L060258-001 | 1 |
| 2 | Bracket, 3 disc models (aluminum) | L060259-001 | 1 |
| 2 | Bracket, 4 disc models (cast iron) | L060285-001 | 1 |
| 3 | Knob, release | G060785-001 | 1 |
| 4 | Spring, release return | G060797-001 | 1 |
| 5 | Screw, release adjustment | W001002-056C | 1 |
| 6 | Spring, release adjustment lock | G060795-001 | 1 |
| 7 | Nameplate | K060407-001 | 1 |
| 8 | Cap plug | W008003-001 | 1 |
| 9 | Stud, cover | G060822-001 | 2 |
| 10 | Stud, pivot | W002005-304A | 1 |
| 11 | Spring, pivot | G060852-001 | 1 |
| 12 | Disc, stationary | H060147-001 | * |
| 13 | Disc, rotating friction | H060157-005 | * |
| 14 | Clip, stabilizer, rotating disc | H060466-001 | * |
| 15 | Operator assembly - Includes "A" thru "T" (not shown as an assembly) | K060476-*** | 1 |
| 15A | Magnet assembly | ** | 1 |
| 15B | Shock mount, magnet assembly | G060813-001 | 1 |
| 15C | Bracket, mounting, magnet assembly | H060544-001 | 1 |
| 15D | Screw, magnet assembly mounting | W001008-001E | 2 |
| 15E | Armature plate assembly - Includes "F" thru "Q" (not shown as an assembly) | H060541-*** | 1 |
| 15F | Armature plate | H060545-003 | 1 |
| 15G | Bushing, nylon | W013005-001 | 2 |

| Item No. | Description | Part Number | Qty. |
|----------|---|--------------|------|
| 15H | Screw, wear adjustment | W002003-001 | 2 |
| 15I | Roll pin | W005003-098 | 1 |
| 15J | Armature lamination assembly | G060788-001 | 1 |
| 15K | Shock mount, armature | G060808-003 | 1 |
| 15L | Spacer, armature | G060798-002 | 2 |
| 15M | Screw, armature mounting | W001007-002E | 2 |
| 15N | Locking plate | G060812-001 | 1 |
| 15P | Lockwasher | W004006-003 | 1 |
| 15Q | Screw, locking plate mounting | W001013-201 | 1 |
| 15R | Carriage bolt | G060803-001 | 2 |
| 15S | Spring, torque (blue) - 61001 | G060791-001 | 2 |
| 15S | Spring, torque (silver) - 61003 & 62006 | G060792-001 | 2 |
| 15S | Spring, torque (red) - 63010 | G060843-001 | 2 |
| 15S | Spring, torque (gold) - 62010 & 63015 | G060793-001 | 2 |
| 15S | Spring, torque (green) - 63020 & 64025 | G060794-001 | 2 |
| 15S | Spring, torque (purple) - 62015 | G061092-001 | 2 |
| 15S | Spring, torque (black) - 63025 | G061093-001 | 2 |
| 15T | Locknut | W003013-001 | 2 |
| 16 | Screw, magnet bracket mounting | W001008-001E | 2 |
| 17 | Bushing, pivot | G060820-001 | 1 |
| 18 | Washer, pivot | W004003-024 | 1 |
| 19 | Nut, pivot adjusting / locking | W003002-002E | 2 |
| 20 | Cover | L060261-001 | 1 |
| 21 | Label, instruction (not shown) | K060496-001 | 1 |
| 22 | Nut, cover | W003001-013 | 2 |
| 23 | Label, release | G060859-001 | 1 |

* Number of rotating discs is shown in the brake model number.

Example - 62006-524 has two rotating discs. The number of stationary discs is one more than the number of rotating discs, with the exception of model 64025-524 which has the same number of stationary discs as rotating discs.

**Part number is determined by one or more of the following: model number, voltage, motor shaft diameter and keyway size.

SPECIFICATIONS

Torque: 1-1/2 through 25 lb-ft.

NEMA Motor Frame Sizes: 56C, 143TC and 145TC.

Enclosures: Aluminum bracket with steel cover.

Cast iron bracket with steel cover (25 lb-ft, 4 disc only)

Voltage: All NEMA single phase voltages and frequencies are standard. Others optional.

Duty: Rated for continuous duty.

Mounting: Direct to NEMA C face. Horizontal or vertical position with slight modifications.

Maximum Ambient Temperature: 40°C

Maximum Input Speed: 3600 rpm

Certified CSA Enclosure 2

ORDERING INFORMATION

Replacement parts can be purchased from your local distributor or from Dings Co. at the address and phone number shown below. Call the Dings Co. for the location of the nearest stocking distributor.

For replacement parts, please furnish this data with your order:

- ♦ Brake model number
- ♦ Part number and description (refer to parts list)
- ♦ If ordering a hub, specify bore diameter and key dimensions
- ♦ If ordering electrical parts, specify voltage and frequency

For a replacement brake, please furnish this data with your order:

- ♦ Brake model number
- ♦ Voltage and frequency
- ♦ Hub bore and keyway dimensions
- ♦ Mounting - horizontal or vertical. If vertical, specify whether above or below motor. If brake includes foot mounting bracket or adapter, specify.

WARRANTY

Seller warrants products manufactured by it and supplied hereunder to be free from defects in materials and workmanship under normal use and proper maintenance for a period of twelve months from date of shipment. If within such period any such products shall be proved to Seller's reasonable satisfaction to be defective, such products shall be repaired or replaced at Seller's option. Seller's obligation and Buyer's exclusive remedy hereunder shall be limited to such repair and replacement and shall be conditioned upon Seller's receiving written notice of any alleged defect no later than 10 days after its discovery within the warranty period and, at Seller's option, the return of such products to Seller, f.o.b. its factory, when such return is feasible. Seller reserves the right to satisfy its warranty obligation in full by reimbursing Buyer for all payments it makes hereunder, and Buyer shall thereupon return the products to Seller. Seller shall have the right to remedy such defects. Seller makes no warranty with respect to wear or use items, such as belts, chains, sprockets, discs and coils, all of which are sold strictly AS IS.

The foregoing warranties are exclusive and in lieu of all other express and implied warranties (except of title) including but not limited to implied warranties of merchantability, fitness for a particular purpose, performance or otherwise, and in no event shall the Seller be liable for claims (based upon breach of express or implied warranty, negligence, product liability, or otherwise) for any other damages, whether direct, immediate, incidental, foreseeable, consequential, or special.

