



90 Series NEMA 4 Enclosure Brake Instructions

Read carefully before attempting to assemble, install, operate or maintain the product described. Protect yourself and others by observing all safety information. Failure to comply with instructions could result in personal injury and/or property damage! Retain instructions for future reference. When unpacking the brake, inspect it carefully for damage that may have occurred during transit.



Figure 1.

DESCRIPTION

This brake is direct acting, electromagnetically released and spring set. It uses rotating and stationary disc contact to supply positive braking action. It retains quick release and setting capabilities at all times.

Simplicity of design has reduced maintenance to an absolute minimum. As with any electromechanical equipment, however, periodic inspection and adjustment will assure optimum performance. As the friction disc wears, the magnet gap will increase. The magnet gap should be checked periodically and adjusted when necessary.

SPECIFICATIONS

MOTOR FRAMES - 324TC - 405TC

HOUSINGS - Cast iron.

DUTY - Rated for continuous duty.

VOLTAGES - All standard NEMA voltages and frequencies available. Other voltages and frequencies are optional.

MOUNTING - Direct to NEMA "C" motor flanges. Adaptors for larger or smaller frames, foot mounting and vertical mounting are available.

SHAFTS - NEMA standard length motor shafts and thru shafts may be used on all models (Cover modification required for thru shafts).

ORDERING INFORMATION

The following data should be furnished with your order for:

REPLACEMENT PARTS

Brake Model Number

Part Number from Tables

Part Description from Tables

(On hub order furnish bore dia. & keyway dimensions. On electrical parts specify voltage, phase & frequency.)

REPLACEMENT BRAKE

Model Number

Voltage, Phase & Frequency

Hub Bore & Keyway Dimensions

Mounting - Horizontal or Vertical. (If vertical, specify whether above or below motor. If brake includes foot mounting bracket or adaptor, specify.)

WARNING

Brake performance and features must be carefully matched to the requirements of the application.

Consideration must be given to torque requirements, especially where an overhauling condition exists, as well as thermal capacity, ambient temperature, atmospheric explosion hazards, type of enclosure and any other unusual conditions.

Improper selection and installation of a brake and/or lack of maintenance may cause brake failure which could result in damage to property and/or injury to personnel.

If injury to personnel could be caused by brake failure, additional means must be provided to insure safety of personnel.

Do not operate manual release or energize brake coil before installation, in order to preserve prealignment of rotating discs for ease of installation.

GENERAL SAFETY INFORMATION

NOTE: These brakes are not intended for accurate positioning applications. They are designed for applications that require rapid stopping and holding power, such as on conveyors, door openers, etc.

- For applications with high inertia-type loads or rapid cycling, the thermal capacity of the brake must be considered.
- Observe all local electrical and safety codes, as well as the National Electrical Code (NEC) and the Occupational Safety and Health Act (OSHA).
- Brake motors and brake gearmotors must be securely and adequately grounded. This can be accomplished by wiring with a grounded metal-clad raceway system, by using a separate ground wire connected to the bare metal of the motor frame, or other suitable means. Refer to NEC Article 250 (Grounding) for additional information. All wiring should be done by a qualified electrician.
- Always disconnect power before working on or near a brake motor, a brake gearmotor, or its connected load. If the power disconnect point is out of sight, lock it in the open position and tag it to prevent unexpected application of power.
- When working on the brake, be sure the load is completely removed, secured or blocked to prevent injury or property damage.
- Provide guarding for all moving parts.
- Be careful when touching the exterior of an operating motor, gearmotor or brake. It may be hot enough to cause injury or to be painful. This condition is normal for modern motors, which operate at higher temperatures when running at rated load and voltage.
- Protect all electrical lead wires and power cables against contact with sharp objects or moving parts.
- Do not kink electrical lead wires and power cables, and never allow them to touch oil, grease, hot surfaces or chemicals.
- Upon usage, the inside surfaces of the brake will contain friction material dust. This dust must be removed before servicing or adjusting the brake. It is important to avoid dispersing dust into the air or inhaling it, as this may be dangerous to your health. To avoid dispersing the dust into the air, DO NOT blow the dust off the brake. Remove dust with a vacuum. Avoid breathing dust. Wear a respirator if dust becomes airborne.

4740 WEST ELECTRIC AVENUE • MILWAUKEE, WI 53219

PHONE 414/672-7830 • FAX 414/672-5354

www.dingsbrakes.com

INSTALLATION

(See Figures 3 & 4 and Tables 1 & 2)

1. Remove hub (31) from brake and position on motor shaft with key according to dimension "N". Stamped part number on hub should face away from motor. Tighten hub set screws with 60 lb. ft. torque.
2. Remove cover nuts (21) and cover (19).
3. Place brake on motor, guiding discs on hub.
4. Bolt brake to motor "C" face with four 5/8 inch socket head cap screws. See Figure 4 for screw length through bracket.
5. Connect coil leads per appropriate wiring diagram in Figure 2 and replace cover.

MANUAL RELEASE (See Figure 3)

To operate release, rotate two rods (5) clockwise until stop screw (17) hits pin. Brake will remain in released position until rods are manually returned to original position, or until electrical power is restored which automatically returns the release rods to the set position.

TORQUE ADJUSTMENT (See Figures 3 & 4 and Table 2)

Brake is factory set for rated torque per spring length "H". To increase stopping time and lower torque, turn four locknuts (9) counterclockwise, increasing dimension "H". All four springs must be set to the same length. Do not decrease spring length "H" as this may cause coil to burn out.

WEAR ADJUSTMENT

(See Figures 3 & 4, Table 2)

Magnet gap "D" increases as friction discs wear. When gap approaches "D" max., adjust gap to "D" min. dimension by turning nuts (11 and 13). Magnet gap can vary from nominal $\pm .005$ " between corners. After setting gap, readjust torque spring length "H". Apply 55 lb-ft torque to bottom jam nuts (11). NOTE: Nut should be black in color.

FRICITION DISC REPLACEMENT

(See Figures 3 & 4, Table 2)

*When the rotating friction disc (3) wears down to a thickness of 1/4", replace disc.

1. Remove cover nuts (21) and cover (19).
2. Unhook loop of torsion springs (10) from pins at rear of magnet plate (12). Remove release stop screws (17) and shim washers (14 & 15).
3. Remove adjusting lock nuts (11), magnet assembly (12), adjusting nuts (13), torque nuts (9), washers (8), torque spring (7) and pressure plate (6).
4. Remove friction disc (3) and stationary disc (4). Replace worn friction discs.
5. Reassemble all parts in reverse order. Set spring length "H" and magnet gap "D". Apply 40 lb-ft torque to bottom jam nuts (11). Assemble manual release. See "Manual Release Assembly".

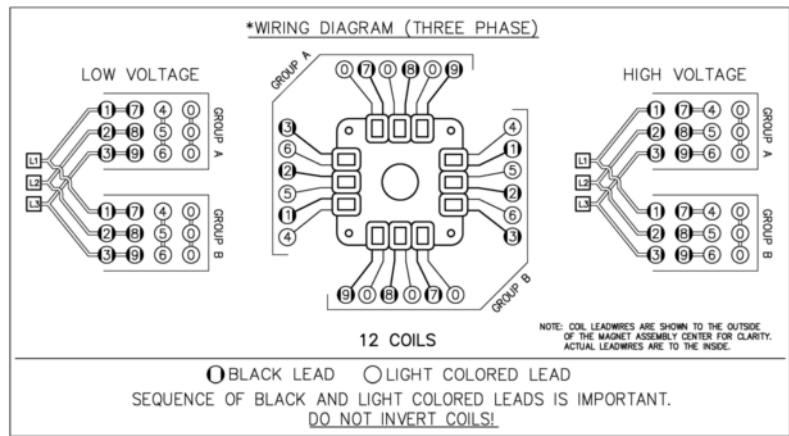

Figure 2. Wiring Diagram

MAGNET COIL REPLACEMENT (See Figures 2 & 3)

Remove magnet assembly (12) as outlined under FRICTION DISC REPLACEMENT.

Coils are held in place with epoxy cement. Force coil off magnet mounting plate and remove excess epoxy from all surfaces.

Replacement coils should be held in place with new epoxy cement. The epoxy cement should be heat resistant and shock resistant.

When installing coils, it is very important to follow EXACTLY the sequence of black and light colored leads as shown in wiring diagram (Figure 2). The brake will not operate properly unless coils are all in the correct position.

MANUAL RELEASE ASSEMBLY (See Figure 3)

When assembling a standard manual release mechanism (Figure 3), add only enough shim washers (14 & 15) to obtain proper release action. Too many shim washers will prevent automatic reset when electrical power is applied. Too few washers will prevent the motor shaft from turning freely. Replace stop screws (17). Wind each torsion spring (10) approximately 1/4 turn and hook spring loop over pin.

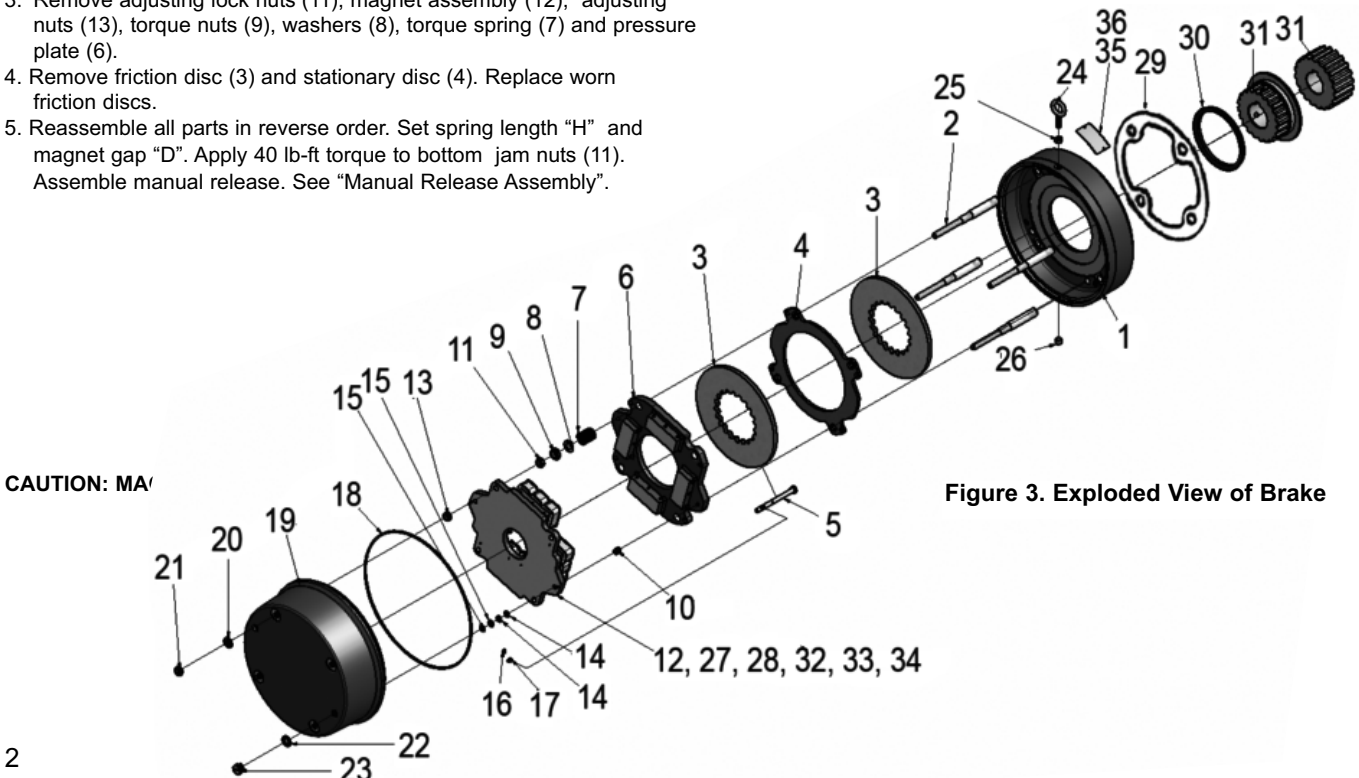

Figure 3. Exploded View of Brake

CAUTION: MA/

Table 1. Parts List

ITEM NO.	MODEL NUMBER														DESCRIPTION	PART NUMBER
	92125-51	92180-51	93230-51	93270-51	94330-51	94360-51	95450-51	92125-52	92180-52	93230-52	93270-52	94330-52	94360-52	95450-52		
	QUANTITY															
1	1	1													Bracket, 2 disc, NEMA 4 w/ Hub Seal	L090162-001
1			1	1											Bracket, 3 disc, NEMA 4 w/ Hub Seal	L090163-001
1					1	1									Bracket, 4 disc, NEMA 4 w/ Hub Seal	L090164-001
1							1								Bracket, 5 disc, NEMA 4 w/ Hub Seal	L090165-001
1								1	1						Bracket, 2 disc, NEMA 4 without Hub Seal	L090162-002
1										1	1				Bracket, 3 disc, NEMA 4 without Hub Seal	L090163-002
1												1	1		Bracket, 4 disc, NEMA 4 without Hub Seal	L090164-002
1														1	Bracket, 5 disc, NEMA 4 without Hub Seal	L090165-002
2	4	4						4	4						Stud Post, 2 disc	H090131-001
2			4	4						4	4				Stud Post, 3 disc	H090131-002
2					4	4						4	4		Stud Post, 4 disc	H090131-003
2							4							4	Stud Post, 5 disc	H090131-004
3	2	2	3	3	4	4	5	2	2	3	3	4	4	5	Disc, Rotating	K090149-001
4	1	1	2	2	3	3	4	1	1	2	2	3	3	4	Disc, Stationary	L090173-001
5	2	2	2	2	2	2	2	2	2	2	2	2	2	2	Rod, Manual Release	G070001-002
6	1	1	1	1	1	1	1	1	1	1	1	1	1	1	Assembly, Pressure Plate	L090171-001
7	4	4	4	4	4	4	4	4	4	4	4	4	4	4	Spring, Torque (Silver)	G080002-001
8	4	4	4	4	4	4	4	4	4	4	4	4	4	4	Washer, Torque Spring	G090304-001
9	4	4	4	4	4	4	4	4	4	4	4	4	4	4	Nut, Torque Spring	W003001-022
10	2	2	2	2	2	2	2	2	2	2	2	2	2	2	Spring, Manual Release Return	G060010-001
11	4	4	4	4	4	4	4	4	4	4	4	4	4	4	Nut, Magnet Assembly Locating	W003003-023F
12	1	1	1	1	1	1	1	1	1	1	1	1	1	1	Magnet Assembly	#
13	4	4	4	4	4	4	4	4	4	4	4	4	4	4	Nut, Magnet Assembly Locking	W003013-010
14	AN	AN	AN	AN	AN	AN	AN	AN	AN	AN	AN	AN	AN	AN	Washer, Manual Release Shim, Thin	W004004-004C
15	AN	AN	AN	AN	AN	AN	AN	AN	AN	AN	AN	AN	AN	AN	Washer, Manual Release Shim, Thick	W004004-003C
16	2	2	2	2	2	2	2	2	2	2	2	2	2	2	Lockwasher, Stop Screw	W004007-007
17	2	2	2	2	2	2	2	2	2	2	2	2	2	2	Screw, Stop	G060029-001
18	1	1	1	1	1	1	1	1	1	1	1	1	1	1	O-ring, cover	W006001-037
19	1	1	1	1	1	1	1	1	1	1	1	1	1	1	Cover	L090160-001
20	4	4	4	4	4	4	4	4	4	4	4	4	4	4	Washer, sealing	W011002-010
21	4	4	4	4	4	4	4	4	4	4	4	4	4	4	Nut, Cover	W003001-020
22	2	2	2	2	2	2	2	2	2	2	2	2	2	2	Gasket, Cap	G070381-001
23	2	2	2	2	2	2	2	2	2	2	2	2	2	2	Cap, Manual Release	G060170-002
24	1	1	1	1	1	1	1	1	1	1	1	1	1	1	Eyebolt, Lifting	W032002-003
25	1	1	1	1	1	1	1	1	1	1	1	1	1	1	Nut, Eyebolt Locking	W003002-003
26	1	1	1	1	1	1	1	1	1	1	1	1	1	1	Plug, Pipe	W010002-002
27	1	1	1	1	1	1	1	1	1	1	1	1	1	1	Clamp, Tube	W021003-001
28	1	1	1	1	1	1	1	1	1	1	1	1	1	1	Screw, Tube Clamp	W001045-085
29								1	1	1	1	1	1	1	Gasket, Motor Mounting	K090134-002
30	1	1	1	1	1	1	1								V-ring, Hub Seal	W011008-005
31	1	1	1	1	1	1	1	1	1	1	1	1	1	1	Hub	@
32	AN	AN	AN	AN	AN	AN	AN	AN	AN	AN	AN	AN	AN	AN	Connector, Crimp	W022003-001
33	3	3	3	3	3	3	3	3	3	3	3	3	3	3	Leadwire, 18 AWG, Class H	W023001-047A
34	AN	AN	AN	AN	AN	AN	AN	AN	AN	AN	AN	AN	AN	AN	Zip Tie	W038001-009A
35	1	1	1	1	1	1	1	1	1	1	1	1	1	1	Nameplate	per order
36	2	2	2	2	2	2	2	2	2	2	2	2	2	2	Screw, Drive, Nameplate	W001012-048

= Part number is dependent on **voltage and torque** of brake - *Contact Factory* for more information

@ = Part number is dependent on **model number and bore size** of brake - *Contact Factory* for more information

AN = As Needed

Table 2. Dimensions

Torque lb-ft	Model No. with hub seal	Wt. Lbs. (with hub seal)	Model No. without hub seal	Wt. Lbs. (without hub seal)	Thermal Capacity HPS/Min	Inertia WK ² lb-ft ²	Dimensions in inches						
							C	N	X	AC	D		H
											MIN	MAX	
125	92125-51	128	92125-52	126	20	1.00	7.88	2.31	2.31	2.16	0.030	0.080	1.38
180	92180-51	128	92180-52	126	20	1.00	7.88	2.31	2.31	2.16	0.030	0.070	1.19
230	93230-51	141	93230-52	139	20	1.30	8.25	2.94	2.94	2.19	0.035	0.080	1.31
270	93270-51	141	93270-52	139	20	1.30	8.25	2.94	2.94	2.19	0.035	0.070	1.19
330	94330-51	149	94330-52	147	20	1.60	8.88	3.56	3.56	3.44	0.040	0.070	1.25
360	94360-51	149	94360-52	147	20	1.60	8.88	3.56	3.56	3.44	0.040	0.070	1.19
450	95450-51	159	95450-52	157	20	1.90	9.50	4.19	4.19	4.06	0.045	0.070	1.19

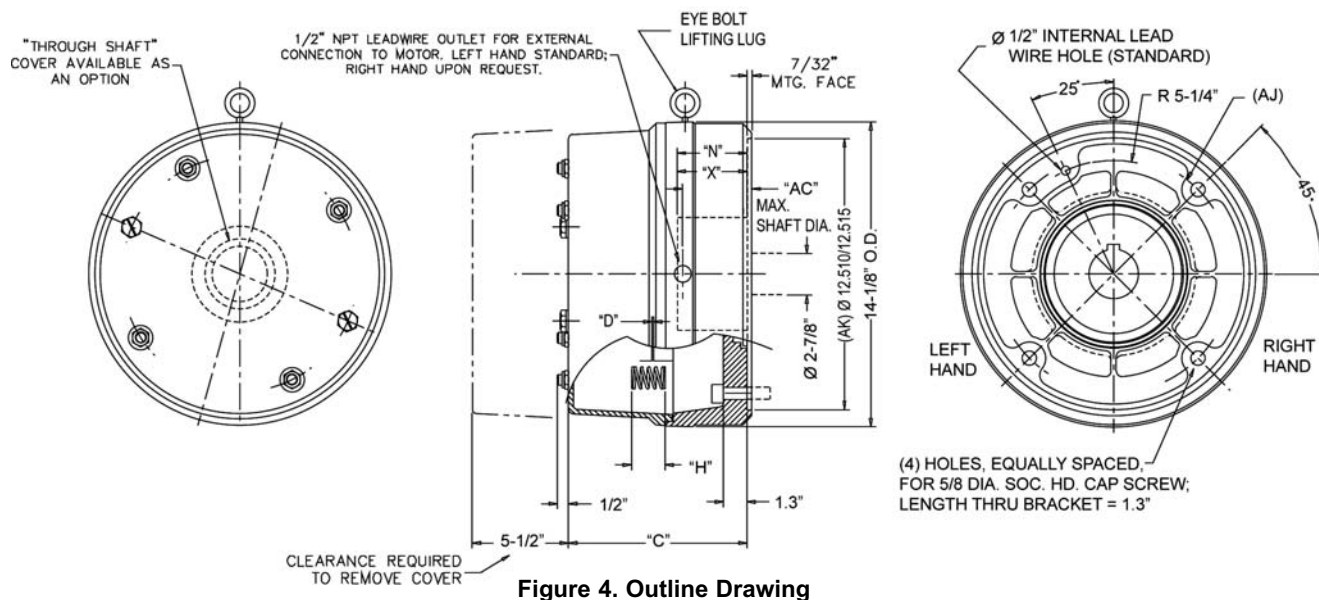

TROUBLE SHOOTING

A. IF BRAKE DOES NOT RELEASE:

1. Check brake visually for broken or damaged parts.
2. Check for broken leadwire or bad electrical connection.
3. Check for correct voltage. Line voltage must correspond to the voltage for which the brake coils are connected. If the line voltage is more than 10% below the voltage for which the brake coils are connected, the magnet will not pull in, causing the coils to burn out within minutes. If the line voltage is more than 10% above the voltage for which the brake coils are connected, the coils will overheat and burn out.
4. Check for burned-out coils (coils may be charred or burned).
5. Check for excessive magnet gap. (See WEAR ADJUSTMENT.)
6. Check for failure or power supply to brake.

B. IF BRAKE DOES NOT STOP:

1. Check brake visually for broken or damaged parts.
2. Make certain hub has not shifted position on the motor shaft and that all rotating discs are fully engaged on the hub.
3. Check that the manual release is in the normal position.
4. Check disc wear. (See WEAR ADJUSTMENT.)

C. IF BRAKE CHATTERS OR HUMS:

1. See that magnet faces are clean. To remove dirt, insert a clean sheet of paper between magnet faces and energize brake. Move paper around between faces to dislodge dirt, then remove paper.
2. Check for low voltage. Magnet will not pull in, and coils will burn out if line voltage is beyond 10% below the voltage the brake coils are connected for.
3. See that magnet faces are parallel within tolerance. Readjust magnet gap to "D" min. (See WEAR ADJUSTMENT.)

D. IF MANUAL RELEASE DOES NOT WORK:

1. Check for broken or damaged parts.
2. Check return spring (10). Brake will not reset automatically if this spring is broken.
3. Check quantity of shim washers (14 & 15) under release stop screws. (See MANUAL RELEASE ASSEMBLY.)