

Table of Contents

Introduction							1
Brake Selection							2
Motor Frame Size	Torque (lb-ft)	Enclosure	Style	Construction	Brake Series	Basic Model #	Pg
Small AC & DC motors	3/8, 3/4	NEMA 2	End Mount	Steel	40	40000-012	3
48C	1.5 - 6	NEMA 2	End Mount	Steel	50	50000-050	4
56C through 145TC	1.5 - 25	NEMA 2	5600 End Mount	Steel	60	60000-5600	5
56C through 145TC	1.5 - 25	NEMA 2	End Mount	Aluminum/Steel	60	60000-524	7
		NEMA 4, no hub seal	End Mount	Aluminum/Steel or Cast Iron	60	60000-545 / 60000-543	9
		NEMA 4 with hub seal	End Mount	Aluminum/Steel or Cast Iron	60	60000-535 / 60000-530	11
		NEMA 4X, no hub seal	End Mount	Cast Iron or Stainless Steel	60	60000-5115 or 60000-5141	9
		NEMA 4X with hub seal	End Mount	Cast Iron or Stainless Steel	60	60000-5116 or 60000-5140	11
56C through 145TC	1.5 - 20	NEMA 2	Double C Face	Aluminum	60	60000-551	13
		NEMA 4	Double C Face	Aluminum	60	60000-5153	13
		NEMA 4X	Double C Face	Aluminum	60	60000-5155	13
		NEMA 4X	Double C Face	Stainless Steel	60	60000-5145	13
182TC through 256TC	1.5 - 25	NEMA 2	End Mount	Aluminum/Steel	1-70	70000-115	15
182TC through 256TC 8700 STYLE 70 SERIES BRAKE	10 - 105	NEMA 2	End Mount	Cast Iron/Steel	70	70000-ES41	17
		NEMA 2	End Mount	Cast Iron	70	70000-EC41	17
		NEMA 4, no hub seal	End Mount	Cast Iron	70	70000-EC61	19
		NEMA 4 with hub seal	End Mount	Cast Iron	70	70000-SC61	21
		NEMA 4X, no hub seal	End Mount	Cast Iron	70	70000-EC6W	19
		NEMA 4X with hub seal	End Mount	Cast Iron	70	70000-SC6W	23
182TC through 256TC 8700 STYLE 70 SERIES BRAKE	10-105	NEMA 2	Double C Face	Cast Iron/Aluminum	70	70000-CE41 / CE42	25
		NEMA 4	Double C Face	Cast Iron/Aluminum	70	70000-CE61 / CE62	27
		NEMA 4X	Double C Face	Cast Iron/Aluminum	70	70000-CE63 / CE64	29
Foot Mount Double Shaft	10 - 75	NEMA 2 & NEMA 4	Foot Mount	Cast Iron/Aluminum	70	70000-DE41 / DE61	31
284TC and 286TC	25 - 175	NEMA 2	End Mount	Cast Iron/Steel or Cast Iron/Aluminum	80	80000-58 or 80000-28	33
		NEMA 4, no hub seal	End Mount	Cast Iron	80	80000-32	35
		NEMA 4 with hub seal	End Mount	Cast Iron	80	80000-29	37
324TC through 405TC	125-450	NEMA 2	End Mount	Cast Iron	90	90000-50	39
		NEMA 4	End Mount	Cast Iron	90	90000-51	39
444TC through 505TC	500-1000	NEMA 2 & NEMA 4	End Mount	Cast Iron	1000	K00000 / L00000	41
HAZARDOUS LOCATION							42
56C through 145TC	1.5 - 15	Hazardous Location	End Mount	Cast Iron	60	8-60000-66B	43
182TC through 256TC	10 - 75	Hazardous Location	End Mount	Cast Iron	70	R70000-9	45
56C through 405TC	1.5 - 450	Maritime Service	End Mount				47
182TC through 256TC	10 - 75	Naval Service	End Mount	Ductile Iron	70	70000-42	48
284TC and 286TC	25 - 180	Naval Service	End Mount	Ductile Iron	80	80000-27	48
Motor Frame Adaptors							49
Foot Mounting Brackets							50
Brake Option Descriptions							51
Brake Option List Price Adders							55
Brake Application Guide							57
Conversions / Product Warranty							59
Sales Offices							60
Model Number Index / Cross Reference to Stearns® Model Numbers							61

The Dings Direct-Acting Difference

[BACK TO TABLE OF CONTENTS](#)

When you need to stop and hold a motor quickly and reliably, you can count on a Dings Electromagnetic Spring-Set Brake to do the job. Dings' brakes are specifically engineered to provide you with years of trouble-free performance.

Simplicity of Design

Our brakes operate on a very simple principle: while the motor is running with power engaged, an electromagnet within the brake pulls back the pressure plate, allowing the friction discs and motor shaft to rotate freely. When power is cut to the motor, the electromagnet releases, instantly stopping the rotating discs and preventing the motor shaft from turning. This **direct acting** design has only one moving part with no complicated linkages to break or fail. You won't have to worry about your brake - leaving you more time for your other responsibilities.

AVAILABLE IN THESE CONFIGURATIONS:

End Mount

Double C Face Coupler

Double Shafted with Foot Mount

NEMA 4X BISSC

Stainless Steel

Hazardous Location

Crane Duty

Marine Duty

Navy

2D drawings and 3D electronic files are available at www.dingsbrakes.com

NEW!! See Dings brake operation on YouTube

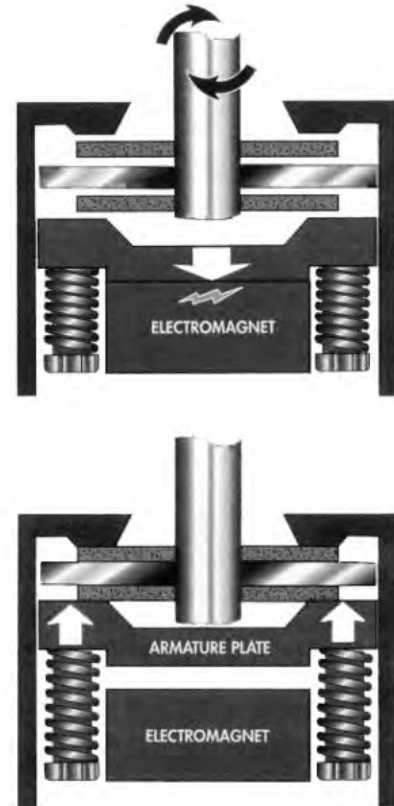

Dings' Brakes are used in many applications, including:

- ♦Tire presses
- ♦Cranes and hoists
- ♦Elevators and walkways
- ♦Satellite positioning equipment
- ♦Conveyors and palletizers
- ♦Motors/speed reducers
- ♦Food and packaging machinery
- ♦And many more...

Brake Selection Guide

[BACK TO TABLE OF CONTENTS](#)

To effectively determine which brake is appropriate for your particular application, you must first calculate the amount of torque required by the system. There are two types of situations in which a brake may be used: **Non-Overhauling** load and **Overhauling** load.

In the case of a non-overhauling load, gravitational forces do not change the energy in the system and the internal friction of the

system is sufficient to hold the load, i.e. an external means is not required to maintain system stability after it has stopped. Examples of this situation would include grinders, horizontal conveyors, etc.

To calculate the torque required in a non-overhauling load situation, refer to the formula and chart below. For overhauling loads, refer to Application Engineering at the end of the catalog.

To calculate torque for a non-overhauling application:

$$T_s = \frac{5252 \times P}{N} \times SF$$

- Where,
- T_s = Static torque, lb-ft
 - P = Motor horsepower, hp
 - N = Motor full load speed, rpm
 - SF = Service Factor
 - 5252 = Constant

Note: Brakes with a 1.0 Service Factor are not intended for critical holding applications.

Motor Hp	1.0 Service Factor							1.4 Service Factor							2.0 Service Factor						
	Speed (RPM)							Speed (RPM)							Speed (RPM)						
	720/750	900/1000	1200	1500	1800	3000	3600	720/750	900/1000	1200	1500	1800	3000	3600	720/750	900/1000	1200	1500	1800	3000	3600
Static Torque Rating of Brake (lb-ft)																					
1/6	11/2	11/2	3/4	3/4	3/4	3/8	3/8	3	11/2	11/2	11/2	3/4	3/4	3/8	3	3	11/2	11/2	11/2	3/4	3/4
1/4	3	3	11/2	11/2	3/4	3/4	3/4	3	3	11/2	11/2	11/2	3/4	3/4	6	3	3	3	11/2	11/2	3/4
1/3	3	3	3	11/2	11/2	3/4	3/4	6	3	3	3	11/2	11/2	3/4	6	6	3	3	3	11/2	11/2
1/2	6	3	3	3	3	11/2	3/4	6	6	6	3	3	11/2	11/2	10	6	6	6	3	3	11/2
3/4	6	6	6	3	3	11/2	11/2	10	10	6	6	6	3	11/2	15	10	10	6	6	3	3
1	10	6	6	6	3	3	3	15	10	10	6	6	3	3	15	15	10	10	6	6	3
1 1/2	15	10	10	6	6	3	3	20	15	10	10	10	6	6	25	20	15	15	10	6	6
2	15	15	10	10	6	6	3	25	20	15	10	10	6	6	35	25	20	15	15	10	6
3	25	20	15	15	10	6	6	35	25	20	15	15	10	10	50	35	35	25	20	15	10
5	50	35	25	20	15	10	10	75	50	35	25	25	15	15	75	75	50	35	35	20	15
7 1/2	70	50	35	35	25	15	15	105	70	50	50	35	20	20	125	105	75	75	50	35	25
10	75	70	50	50	35	20	15	105	105	70	50	50	35	25	175	125	105	75	75	35	35
15	125	105	70	70	50	35	25	175	125	105	75	75	50	35	230	175	175	105	105	75	50
20	180	125	105	75	70	50	35	230	175	125	105	105	50	50	330	270	175	175	125	75	75
25	230	180	125	105	75	50	50	270	230	175	125	105	75	75	450	330	230	175	175		75
30	230	180	180	125	105	75	50	330	270	230	175	125	75	75	450	360	270	230	175		
40	330	270	180	180	125	75	75	450	330	270	230	175					360	330	270		
50	450	330	230	180	180		75		450	330	270	230					450	360	330		
60	450	360	270	230	180					450	330	270						450	360		
75		450	330	270	230						450	330							450		
100			450	360	330							450									
125				450	450																
150					450																

Selection by Frame Size x= mounts directly, ①= adaptor required

Brake Series	Torque Ratings in lb-ft	Motor Frame Size									
		small/fractional hp	48C	56C	143TC 145TC	182TC 184TC	213TC 215TC	254TC 256TC 254UC 256UC	284TC 286TC 284UC 286UC	324/326TC 324/326UC 324/326TSC 324/326USC	364/365TC 364/365UC 364/365TSC 364/365USC
40	3/8 & 3/4	X									
50	1.5-6		X	①	①						
5600 Style 60	1.5-25		①	X	X	①	①	①	①		
60	1.5-25		①	X	X	①	①	①	①		
1-70	1.5-25			①	①	X	X	X	①		
70	10-105			①	①	X	X	X	①		
80	25-175					①	①	①	X	①	①
90	125-450								①	X	X

40 Series End Mount

For Small AC and DC Motors
Torque Ratings: 3/8 and 3/4 lb-ft

[BACK TO TABLE OF CONTENTS](#)



Designed for Dayton®, Bison, Bodine® and Klauber (KMG) type motors and gearmotors.

Specifications:

Reaction Time: 15-20 milliseconds (release and set)
Maximum RPM: 3600
CSA File #LR13814
Instructions & Parts Manual: BK4042

Design Features:

Selectable torque: Two rotating friction discs are used for 3/4 lb-ft torque and one friction disc is used for 3/8 lb-ft torque.
Retrofit to small AC and DC motors.
Plated internal parts - RoHS compliant.

Enclosure Type:

Dripproof Enclosure
NEMA 2, IP40
Steel cover and mounting bracket

Model #	Torque lb-ft (lb-in)	Wt. Lbs.	Inertia Wk ² lb-ft ²	Manual Release	List Price
42001-012	3/8 or 3/4 (4.5 or 9)	3	0.001	No	\$
42001-013	3/8 or 3/4 (4.5 or 9)	3	0.001	Yes	\$

Brake Model Number Definition

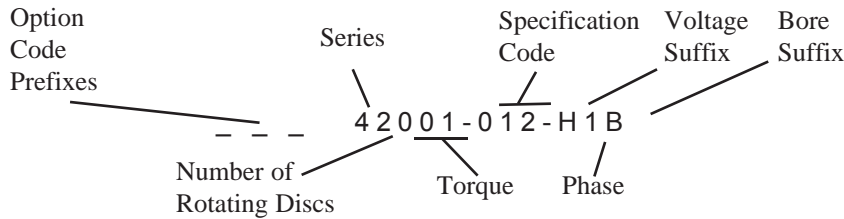

Standard Voltages (single phase only):

Suffix	Voltage
H	115V, 60Hz
M	220/230V, 60 Hz

Standard Hub Bore Sizes:

Suffix	Size	Keyway
A	8mm	None
B	3/8"	None
C	1/2"	None
D	5/8"	None

Maximum bore diameter is 5/8"

Available Options:

Class H Insulation Prefix Q

Refer to pages 51-56 for option descriptions and pricing.

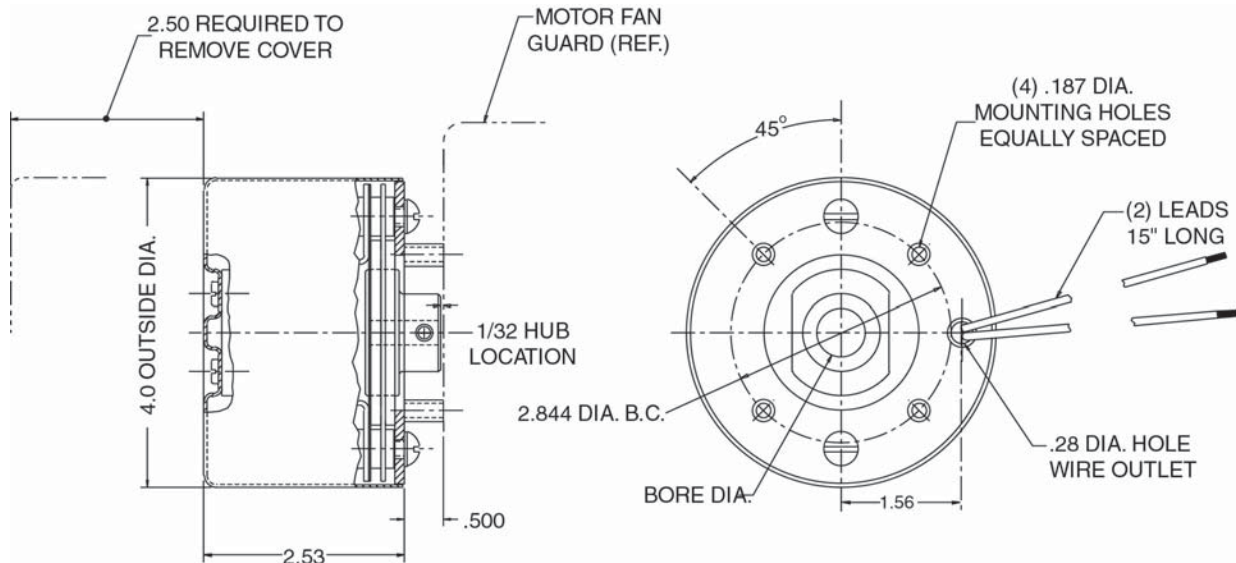

50 Series End Mount

NEMA Frame Size 48C
Torque Ratings: 1.5 to 6 lb-ft

[BACK TO TABLE OF CONTENTS](#)

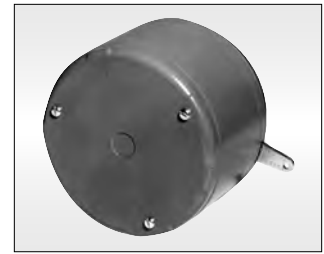

Ideal for OEM applications and brake kits

Specifications:

Reaction Time: 15-20 milliseconds (release and set)

AK: 3" Register

AJ: 3.75" Bolt Circle

Thermal Capacity: 4 HPS/MIN

Maximum RPM: 3600

CSA File #LR13814

Coil insulation: Class B Standard, Class H Optional

Instructions & Parts Manual: BK4618

Enclosure Type:

Dripproof Enclosure

NEMA 2, IP40

Steel cover and mounting bracket

Design Features:

RoHS compliant

Torque adjustable for specific applications

Spring set, electrically released

Deadman release (Available without release)

Splined hub

Through shaft knockout standard, all models

Torque lb-ft	Model # Internal lead connection	Replaces Stearns® Model Number	List Price Internal lead connection	Model # Internal/external lead connection	Replaces Stearns® Model Number	List Price Internal/external lead connection	Wt Lbs.	Inertia Wk ² lb-ft ²	Manual Release*
1.5	51001-050	1-048-151-01	\$	51001-080	1-048-151-00	\$	7	0.002	Yes*
3	51003-050	1-048-161-01	\$	51003-080	1-048-161-00	\$	7	0.002	Yes*
6	51006-050	1-048-171-01	\$	51006-080	1-048-171-00	\$	7	0.002	Yes*

*For brakes without manual release, use model 5xxxx-05A or 5xxxx-08A. Stearns® is a registered trademark of Rexnord Corporation.

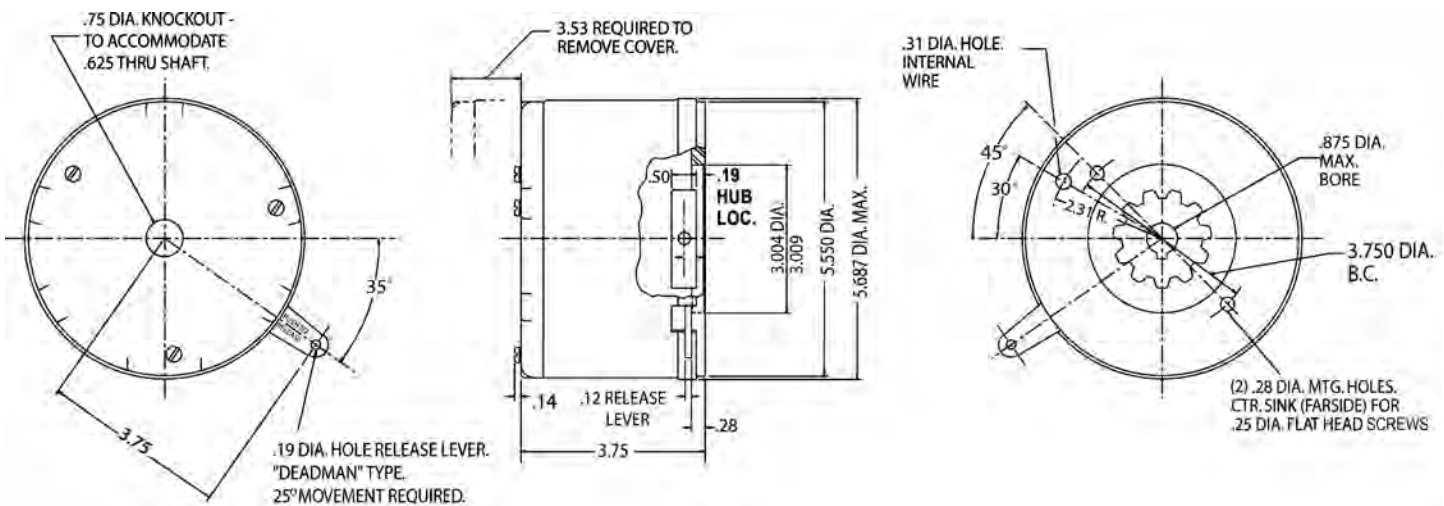

Brake Model Number Definition

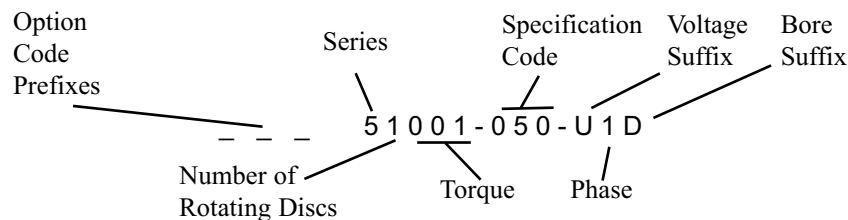

Standard Voltages (single phase only):	
Suffix	Voltage
U	230/460V, 60 Hz or 190/380V, 50 Hz
R	115/230V, 60 Hz
T	220/440V, 60 Hz
P	575V, 60 Hz
Special voltages available.	

Standard Hub Bore Sizes:		
Suffix	Size	Keyway
D	5/8"	3/16" x 3/32"
Special bore sizes available.		

Available Options:	Prefix
Adapter to Larger Frame Size(s)	A
Direct Current (DC Voltage)	DD
Tropical Protection	P
Class H Insulation	Q
Refer to pages 51-56 for option descriptions and pricing.	

60 Series End Mount

5600 Style

NEMA Frame Sizes 56C, 143TC, 145TC

Torque Ratings: 1.5 to 25 lb-ft

[BACK TO TABLE OF CONTENTS](#)



Ideal for OEM Applications and Brake Kits

Specifications:

Reaction Time: 15-20 milliseconds (release and set)
 AK: 4.5" Register
 AJ: 5.88" Bolt Circle
 Thermal Capacity: 6 HPS/MIN
 Maximum RPM: 3600
 CSA File #LR13814
 Coil insulation: 1.5 – 3 lb-ft Class B std, Class H Optional
 6 – 25 lb-ft Class H std
 Mounting: 1.5 – 6 lb-ft are all-position mounting
 10 – 25 lb-ft horizontal mounting only
 Instructions & Parts Manual: BK4684

Design Features:

RoHS compliant
 Direct acting design with no linkages to break
 One moving part for longer life
 Single point air gap adjustment
 Through shaft knockout standard on all models
 Splined hub
 Spring set, electrically released
 Manual release, automatic reset

Enclosure Type:

Dripproof Enclosure
 NEMA 2, CSA 2, IP41
 Stamped steel cover with steel bracket

*Brake Model Number Description

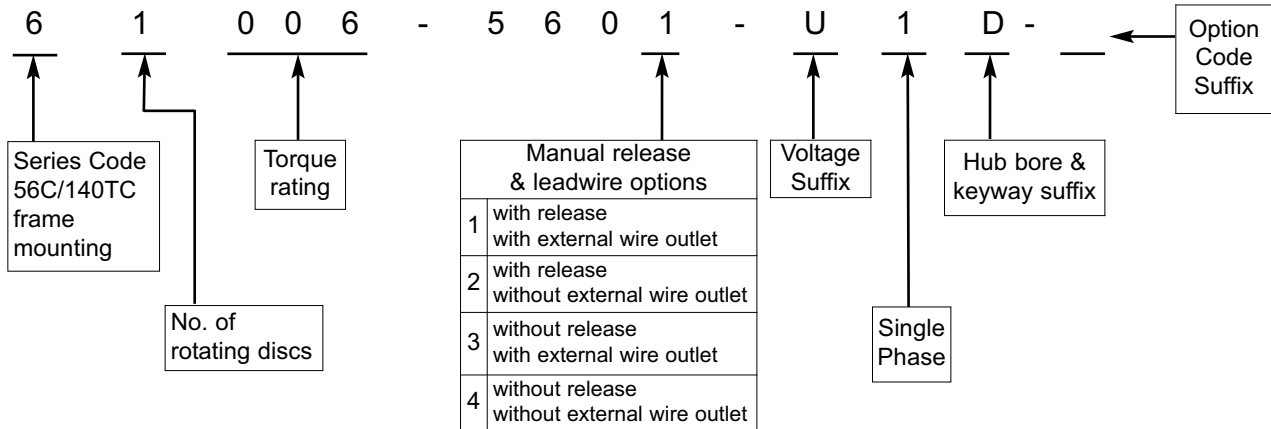

Standard Voltages (single phase only):	
Suffix	Voltage
Y	110/220V, 50Hz
P	575V, 60 Hz
R	115/230V, 60 Hz
T	220/440V, 60 Hz
U	230/460V, 60 Hz or 190/380V, 50 Hz
1	115/208-230V, 60 Hz
5	208-230/460V, 60 Hz

Special voltages available.

Standard Hub Bore Sizes:		
Suffix	Size	Keyway
D	5/8"	3/16" x 3/32"
F	7/8"	3/16" x 3/32"

Special bore sizes available.

Available Options:	Suffix
Adapter to Larger Frame Size(s)	A
Reverse Adapter	AB
Foot Mounting Bracket	F
Class H Insulation	Q

Refer to pages 51-56 for option descriptions and pricing.

Torque Rating lb-ft	Model Number*	Direct Drop-in replacement for Stearns® Model	Number of friction discs	Thermal Capacity HPS/MIN	Inertia lb-ft ²	Dimensions					List Price
						C	AC	G	X	N ± 1/32"	
1.5	61001-560*	1-056-001-00	1	6	0.006	4.01	1.50	0.31	0.81	1.00	\$
3	61003-560*	1-056-011-00	1	6	0.006	4.01	1.50	0.31	0.81	1.00	\$
6	61006-560*	1-056-021-00	1	6	0.006	4.01	1.50	0.31	0.81	1.00	\$
10	62010-560*	1-056-031-00	2	6	0.011	4.01	1.50	0.31	0.81	1.00	\$
15	62015-560*	1-056-041-00	2	6	0.011	4.01	1.50	0.31	0.81	1.00	\$
20	63020-560*	1-056-051-00	3	6	0.015	4.39	1.88	0.69	1.18	1.38	\$
25	63025-560*	1-056-061-00	3	6	0.015	4.39	1.88	0.69	1.18	1.38	\$

Stearns® is a registered trademark of Rexnord Corporation.

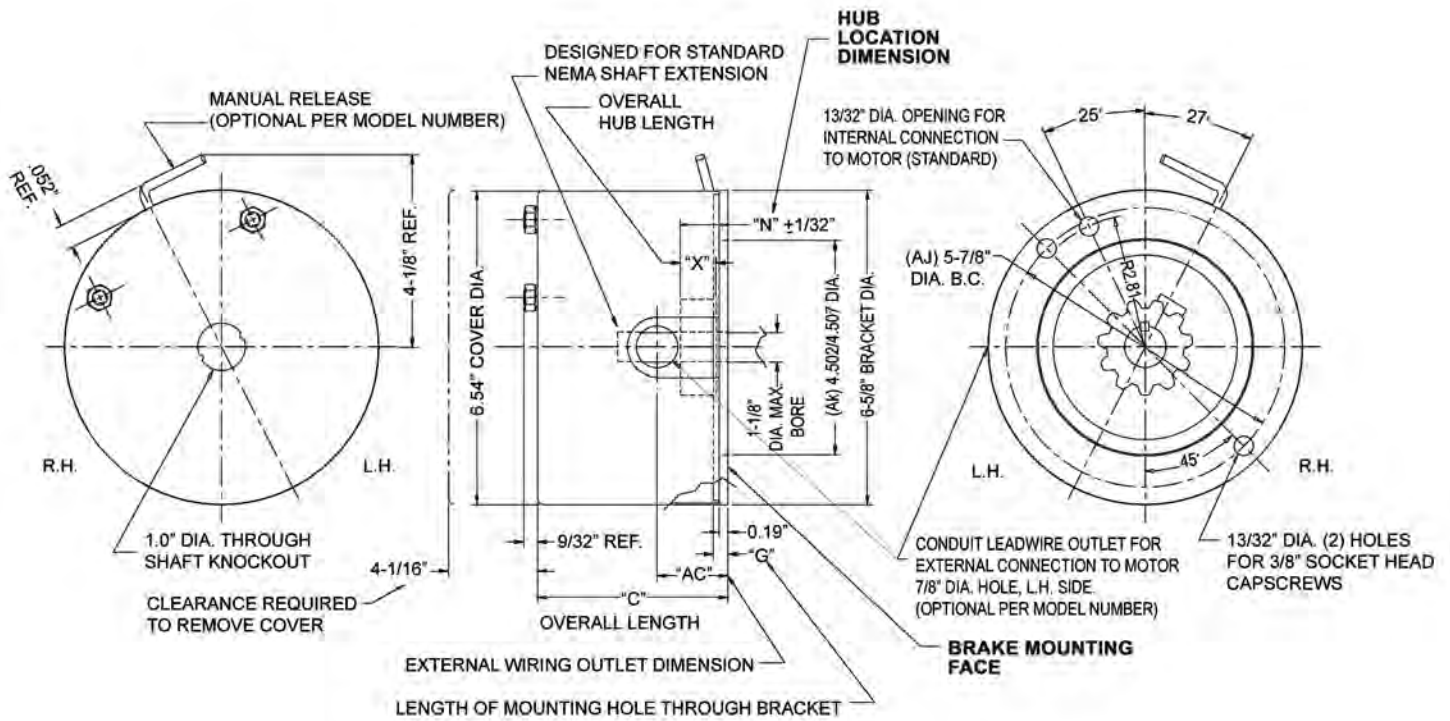

60 Series End Mount

[BACK TO TABLE OF CONTENTS](#)

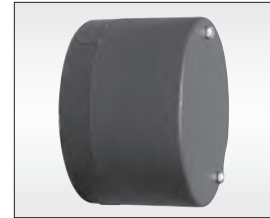

NEMA Frame Sizes 56C, 143TC, 145TC

Torque Ratings: 1.5 to 25 lb-ft

Dripproof NEMA 2, CSA 2, IP41

60 Series Specifications:

Reaction Time: 15-20 milliseconds
(release and set)

AK: 4.5" Register

AJ: 5.88" Bolt Circle

Thermal Capacity: 6 HPS/MIN

Maximum RPM: 3600

Coil insulation:

Class B : 1.5, 3, 10 & 15 lb-ft brakes (Class H optional)

Class H : 6, 20 & 25 lb-ft brakes

CSA File #LR13814

Design Features:

- Direct acting design with no linkages to break
- One moving part for longer life
- Torque adjustable for specific applications
- Spined hub
- Spring set, electrically released
- Manual release, automatic reset
- Plated internal parts - RoHS compliant
- All position brake available

NEMA 2 Brake Specifications:

External paint: Red primer

Lead wires: Internal or conduit connections

Nameplate: Thermally printed adhesive label (pre-masked)

Instructions and Parts Manual: BK4655

Brake Model Number Description

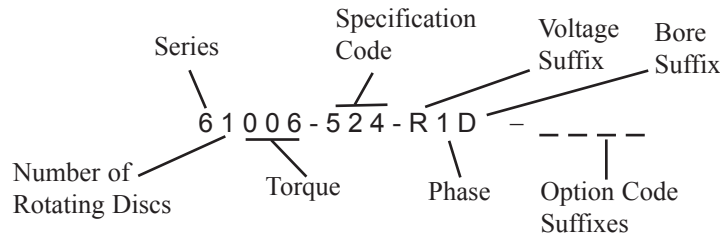

Standard AC Voltages

(single phase only):

Suffix	Voltage
Y	110/220V, 50Hz
U	230/460V, 60 Hz or 190/380V, 50 Hz
5	208-230/460V, 60 Hz
R	115/230V, 60 Hz
1	115/208-230V, 60 Hz
T	220/440V, 60 Hz
P	575V, 60 Hz

Special voltages available.

Optional DC Voltages

(See price for DC modification):

Suffix	Voltage	List Price
A	12	\$
B	24	\$
C	36	\$
D	48	\$
7	76	\$
E	95	\$
H	115	\$
M	230	\$

Special voltages available.

Available Options:

	Suffix
Adapter to Larger Frame Size(s)	A
Reverse Adapter	AB
Foot Mounting Bracket	F
Heavy-Duty Rotating Friction Disc with Hardened Steel Hub	H
Marine/Maritime Duty with MIL-SPEC paint per TT-P-645 & MIL-DTL-15090	M
Marine/Maritime Duty	N
Tropical Protection	P
Internal Space Heater	R
Stainless Steel Stationary Disc	S
Through Shaft	T
Class H Insulation	Q
Vertical Mounting	
Vertical Over, or above motor	VO
Vertical Under, or below motor	VU
Micro-Switch Warning	XS

Refer to pages 51-56 for option descriptions & pricing.

Standard Hub Bore Sizes:

Suffix	Size	Keyway
D	5/8"	3/16" x 3/32"
F	7/8"	3/16" x 3/32"

Special bore sizes available.

NEMA 2 / IP41 Enclosure

BACK TO TABLE
OF CONTENTS

Torque lb-ft	Dings Model #	Replacement for Stearns® Model (NOTE1)	Construction	Wt. Lbs.	Inertia Wk ² lb-ft ²	Dimensions in inches					List Price
						C	N	X	AC	G	
1.5	61001-524	1-056-001-00	Aluminum/Steel	8	0.006	4.13	1.13	0.88	0.59	1.19	\$
3	61003-524	1-056-011-00	Aluminum/Steel	8	0.006	4.13	1.13	0.88	0.59	1.19	\$
6	61006-524	1-056-021-00	Aluminum/Steel	8	0.006	4.13	1.13	0.88	0.59	1.19	\$
10	62010-524	1-056-031-00	Aluminum/Steel	8	0.010	4.13	1.13	0.88	0.59	1.19	\$
15	63015-524	1-056-041-00	Aluminum/Steel	9	0.015	4.50	1.44	1.19	0.59	1.56	\$
20	63020-524	1-056-051-00	Aluminum/Steel	9	0.015	4.50	1.44	1.19	0.59	1.56	\$
25	64025-524	1-056-061-00	Cast Iron/Steel	16	0.020	5.19	2.00	1.34	1.56	2.25	\$

NOTE 1: Hub length and location differ.
For a direct drop-in, refer to Dings 5600 Series Brake on pages 5 & 6.

Stearns® is a Registered Trademark of Rexnord Corporation

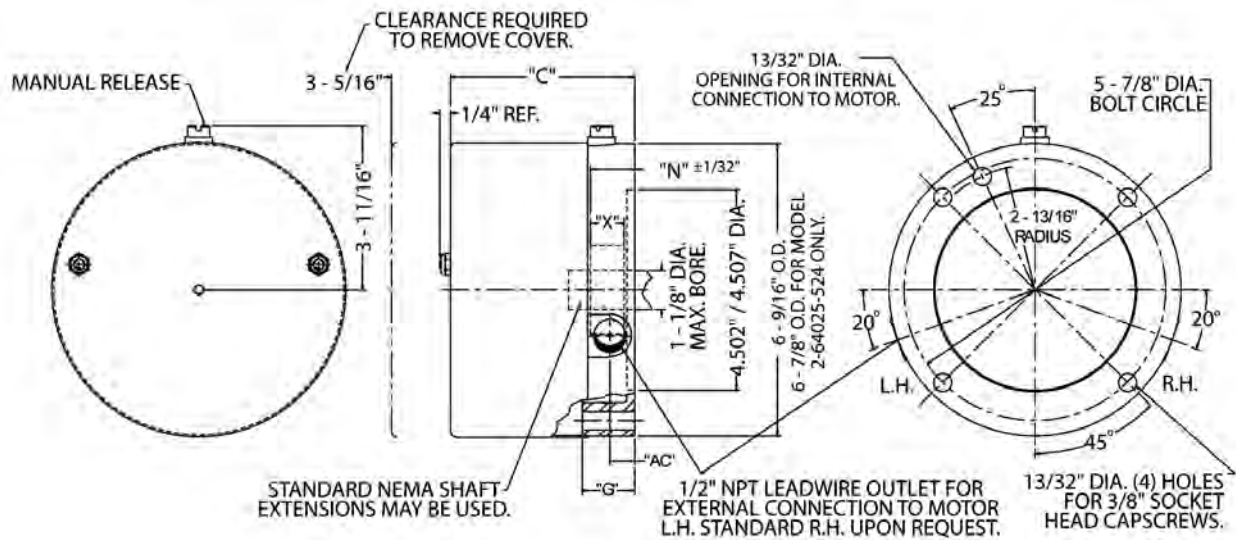

60 Series End Mount

NEMA Frame Sizes 56C, 143TC, 145TC

Torque Ratings: 1.5 to 25 lb-ft

NEMA 4/4X, CSA 4, IP56

without hub seal for Non-TEFC applications

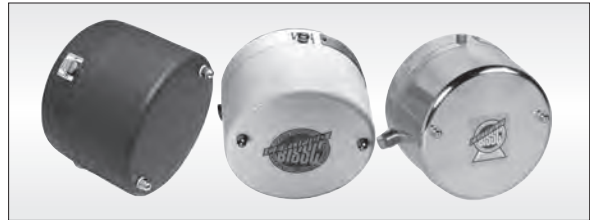

[BACK TO TABLE OF CONTENTS](#)

60 Series Specifications:

- Reaction Time: 15-20 milliseconds (release and set)
- AK: 4.5" Register
- AJ: 5.88" Bolt Circle
- Thermal Capacity: 6 HPS/MIN
- Maximum RPM: 3600
- Coil insulation:
- Class B : 1.5, 3, 10 & 15 lb-ft brakes (Class H optional)
- Class H : 6, 20 & 25 lb-ft brakes
- CSA File #LR13814

Design Features:

- Direct acting design with no linkages to break
- One moving part for longer life
- Torque adjustable for specific applications
- Splined hub
- Spring set, electrically released
- Manual release, automatic reset
- Plated internal parts - RoHS compliant
- All position brake available

NEMA 4 Non-TEFC Specifications:

- External paint: Red primer
- Lead wires: Internal or conduit connections
- Nameplate: Aluminum/Steel brake = Thermally printed adhesive label (pre-masked)
- Cast iron brake = Riveted stamped stainless steel
- Instructions and Parts Manual: Aluminum/Steel brake = BK4710
- Cast iron brake = BK4660

NEMA 4X Non-TEFC Specifications:

- External paint: Cast Iron: FDA approved white epoxy
- Stainless Steel: None
- BISSC Certified Authorization #695
- Lead wires: Internal or conduit connections
- Nameplate: Riveted stamped stainless steel (pre-masked)
- Instructions and Parts Manual: Cast iron brake = BK4660
- Stainless steel brake = BK4661

Brake Model Number Description

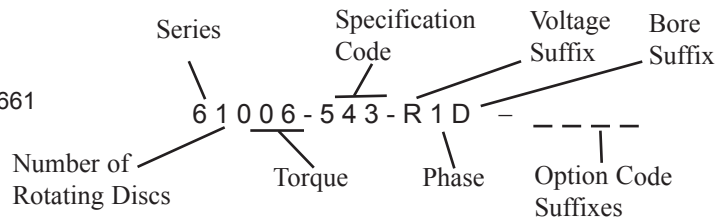

Standard AC Voltages (single phase only):	
Suffix	Voltage
Y	110/220V, 50Hz
U	230/460V, 60 Hz or 190/380V, 50 Hz
5	208-230/460V, 60 Hz
R	115/230V, 60 Hz
1	115/208-230V, 60 Hz
T	220/440V, 60 Hz
P	575V, 60 Hz

Special voltages available.

Optional DC Voltages (See price for DC modification):		
Suffix	Voltage	List Price Adder
A	12	\$
B	24	\$
C	36	\$
D	48	\$
7	76	\$
E	95	\$
H	115	\$
M	230	\$

Special voltages available.

Standard Hub Bore Sizes:		
Suffix	Size	Keyway
D	5/8"	3/16" x 3/32"
F	7/8"	3/16" x 3/32"

Special bore sizes available.

Available Options:	Suffix
Adapter to Larger Frame Size(s)	A
Reverse Adapter	AB
Foot Mounting Bracket	F
Heavy-Duty Rotating Friction Disc with Hardened Steel Hub	H
Marine/Maritime Duty with MIL-SPEC paint per TT-P-645 & MIL-DTL-15090	M
Marine/Maritime Duty	N
Tropical Protection	P
Internal Space Heater	R
Stainless Steel Stationary Disc	S
Through Shaft	T
Class H Insulation	Q
Vertical Mounting	
Vertical Over, or above motor	VO
Vertical Under, or below motor	VU
Micro-Switch Warning	XS

Refer to pages 51-56 for option descriptions & pricing.

NEMA 4 / IP56 Enclosure no hub seal

Torque lb-ft	Dings Model #	Replacement for Stearns® Model (NOTE1)	Construction	Wt. Lbs.	Inertia Wk ² lb-ft ²	Dimensions in inches					List Price
						C	N	X	AC	G	
1.5	61001-545	1-056-002-80	Aluminum/Steel	10	0.008	4.13	1.13	0.88	0.59	1.19	\$
	61001-543	—	Cast Iron	16	0.008	4.81	1.59	0.88	0.94	1.63	\$
3	61003-545	1-056-012-80	Aluminum/Steel	10	0.008	4.13	1.13	0.88	0.59	1.19	\$
	61003-543	—	Cast Iron	16	0.008	4.81	1.59	0.88	0.94	1.63	\$
6	61006-545	1-056-022-80	Aluminum/Steel	10	0.008	4.13	1.13	0.88	0.59	1.19	\$
	61006-543	—	Cast Iron	17	0.008	4.81	1.59	0.88	0.94	1.63	\$
10	62010-545	1-056-032-80	Aluminum/Steel	10	0.013	4.13	1.13	0.88	0.59	1.19	\$
	62010-543	—	Cast Iron	17	0.013	4.81	1.59	0.88	0.94	1.63	\$
15	63015-545	1-056-042-80	Aluminum/Steel	11	0.019	4.50	1.44	1.19	0.96	1.56	\$
	63015-543	—	Cast Iron	18	0.019	5.13	1.90	1.19	1.25	1.94	\$
20	63020-545	1-056-052-80	Aluminum/Steel	11	0.019	4.50	1.44	1.19	0.96	1.56	\$
	63020-543	—	Cast Iron	18	0.019	5.13	1.90	1.19	1.25	1.94	\$
25	64025-543	—	Cast Iron	19	0.024	5.44	2.05	1.34	1.56	2.25	\$

NOTE 1: Hub length and location differ.

Stearns® is a Registered Trademark of Rexnord Corporation

WASHDOWN NEMA 4X / IP56 Enclosure no hub seal

Torque lb-ft	Model #	Construction	Wt. Lbs.	Inertia Wk ² lb-ft ²	Dimensions in inches					List Price
					C	N	X	AC	G	
1.5	61001-5115	Cast Iron	16	0.008	4.81	1.59	0.88	0.94	1.63	\$
	61001-5141	Stainless Steel	16	0.008	4.81	1.59	0.88	0.94	1.63	\$
3	61003-5115	Cast Iron	16	0.008	4.81	1.59	0.88	0.94 <td 1.63	\$	
	61003-5141	Stainless Steel	16	0.008	4.81	1.59	0.88	0.94	1.63	\$
6	61006-5115	Cast Iron	17	0.008	4.81	1.59	0.88	0.94	1.63	\$
	61006-5141	Stainless Steel	17	0.008	4.81	1.59	0.88	0.94	1.63	\$
10	62010-5115	Cast Iron	17	0.013	4.81	1.59	0.88	0.94	1.63	\$
	62010-5141	Stainless Steel	17	0.013	4.81	1.59	0.88	0.94	1.63	\$
15	63015-5115	Cast Iron	18	0.019	5.13	1.90	1.19	1.25	1.94	\$
	63015-5141	Stainless Steel	18	0.019	5.13	1.90	1.19	1.25	1.94	\$
20	63020-5115	Cast Iron	18	0.019	5.13	1.90	1.19	1.25	1.94	\$
	63020-5141	Stainless Steel	18	0.019	5.13	1.90	1.19	1.25	1.94	\$
25	64025-5115	Cast Iron	19	0.022	5.44	2.05	1.34	1.56	2.25	\$
	64025-5141	Stainless Steel	19	0.022	5.44	2.05	1.34	1.56	2.25	\$

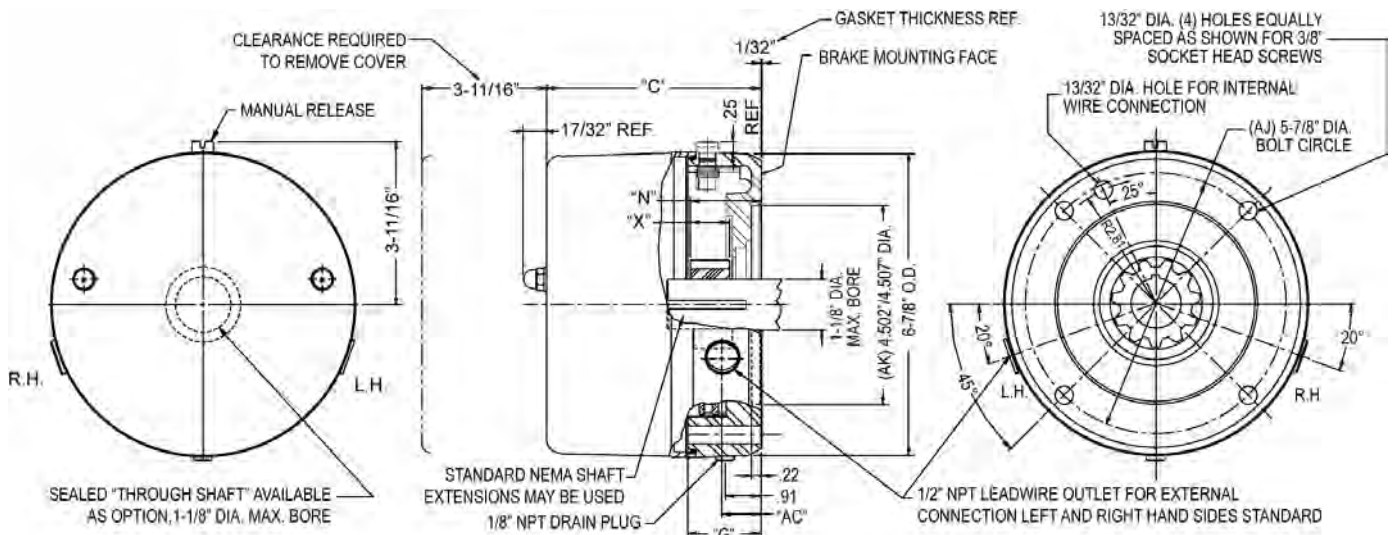

60 Series End Mount

NEMA Frame Sizes 56C, 143TC, 145TC
Torque Ratings: 1.5 to 25 lb-ft

NEMA 4/4X, CSA 4, IP56* with hub seal for TEFC applications

*To obtain full IP56 protection, the customer shaft, hub bore, key and keyway's mating surface(s) must be sealed to meet IP56. Considerations should be reviewed to appropriately seal mounting hardware as well. Contact factory for details and/or assistance.



[BACK TO TABLE OF CONTENTS](#)

60 Series Specifications:

Reaction Time: 15-20 milliseconds (release and set)
AK: 4.5" Register
AJ: 5.88" Bolt Circle
Thermal Capacity: 6 HPS/MIN
Maximum RPM: 3600
Coil insulation:
Class B : 1.5, 3, 10 & 15 lb-ft brakes (Class H optional)
Class H : 6, 20 & 25 lb-ft brakes
CSA File #LR13814

Design Features:

Direct acting design with no linkages to break
One moving part for longer life
Torque adjustable for specific applications
Splined hub
Spring set, electrically released
Manual release, automatic reset
Plated internal parts - RoHS compliant
All position brake available

NEMA 4 TEFC Specifications:

External paint: Red primer
Lead wires: Conduit connections
Nameplate: Aluminum/Steel brake: Thermally printed adhesive label (pre-masked)
Cast iron brake: Riveted stamped stainless steel
Instructions and Parts Manual: Aluminum/Steel brake = BK4710
Cast iron brake = BK4660

NEMA 4X TEFC Specifications:

External paint: Cast Iron: FDA approved white epoxy
Stainless Steel: None
BISCC Certified Authorization #695
Lead wires: Conduit connections
Nameplate: Riveted stamped stainless steel (pre-masked)
Instructions and Parts Manual:
Cast iron brake = BK4660
Stainless steel brake = BK4661

Brake Model Number Description

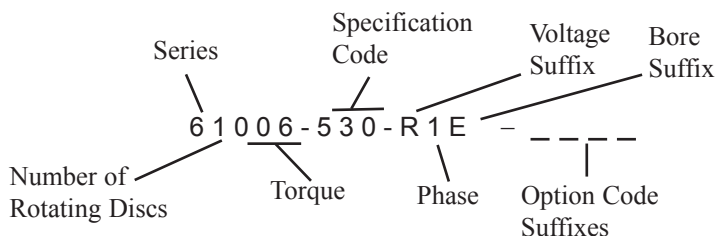

Standard AC Voltages (single phase only):	
Suffix	Voltage
Y	110/220V, 50Hz
U	230/460V, 60 Hz or 190/380V, 50 Hz
5	208-230/460V, 60 Hz
R	115/230V, 60 Hz
1	115/208-230V, 60 Hz
T	220/440V, 60 Hz
P	575V, 60 Hz

Special voltages available.

Optional DC Voltages (See price for DC modification):		
Suffix	Voltage	List Price Adder
A	12	\$
B	24	\$
C	36	\$
D	48	\$
7	76	\$
E	95	\$
H	115	\$
M	230	\$

Special voltages available.

Standard Hub Bore Sizes:		
Suffix	Size	Keyway
D	5/8"	3/16" x 3/32"
F	7/8"	3/16" x 3/32"

Special bore sizes available.

Available Options:	Suffix
Adapter to Larger Frame Size(s)	A
Reverse Adapter	AB
Foot Mounting Bracket	F
Heavy-Duty Rotating Friction Disc with Hardened Steel Hub	H
Marine/Maritime Duty with MIL-SPEC paint per TT-P-645 & MIL-DTL-15090	M
Marine/Maritime Duty	N
Tropical Protection	P
Internal Space Heater	R
Stainless Steel Stationary Disc	S
Through Shaft	T
Class H Insulation	Q
Vertical Mounting	
Vertical Over, or above motor	VO
Vertical Under, or below motor	VU
Micro-Switch Warning	XS

Refer to pages 51-56 for option descriptions & pricing.

NEMA 4 / IP56 Enclosure With hub seal

Torque lb-ft	Model #	Replacement for Stearns® Model (NOTE1)	Construction	Wt. lbs.	Inertia Wk ² lb-ft ²	Dimensions in inches						List Price
						C	N	X Overall length of hub, gap, & V-ring	Xh Hub only length	AC	G	
1.5	61001-535	1-056-002-00	Aluminum/Steel	10	0.008	4.72	1.68	1.47	.88	1.18	1.63	\$
	61001-530	—	Cast Iron	16	0.008	4.81	1.59	1.37	.88	0.94	1.63	\$
3	61003-535	1-056-012-00	Aluminum/Steel	10	0.008	4.72	1.68	1.47	.88	1.18	1.63	\$
	61003-530	1-056-212-00	Cast Iron	16	0.008	4.81	1.59	1.37	.88	0.94	1.63	\$
6	61006-535	1-056-022-00	Aluminum/Steel	10	0.008	4.72	1.68	1.47	.88	1.18	1.63	\$
	61006-530	1-056-222-00	Cast Iron	17	0.008	4.81	1.59	1.37	.88	0.94	1.63	\$
10	62010-535	1-056-032-00	Aluminum/Steel	10	0.013	4.72	1.68	1.47	.88	1.18	1.63	\$
	62010-530	1-056-232-00	Cast Iron	17	0.013	4.81	1.59	1.37	.88	0.94	1.63	\$
15	63015-535	1-056-042-00	Aluminum/Steel	11	0.019	5.10	2.00	1.78	1.19	1.18	1.94	\$
	63015-530	1-056-242-00	Cast Iron	18	0.019	5.13	1.90	1.93	1.19	0.94	1.94	\$
20	63020-535	1-056-052-00	Aluminum/Steel	11	0.019	5.10	2.00	1.78	1.19	1.18	1.94	\$
	63020-530	1-056-252-00	Cast Iron	18	0.019	5.13	1.90	1.93	1.19	0.94	1.94	\$
25	64025-530	1-056-262-00	Cast Iron	19	0.024	5.44	2.05	1.83	1.34	1.56	2.25	\$

WASHDOWN NEMA 4X / IP56 Enclosure With hub seal

Torque lb-ft	Model #	Replacement for Stearns® Model (NOTE1)	Construction	Wt. lbs.	Inertia Wk ² lb-ft ²	Dimensions in inches						List Price
						C	N	X Overall length of hub, gap, & V-ring	Xh Hub only length	AC	G	
1.5	61001-5116	—	Cast Iron	16	0.008	4.81	1.59	1.37	.88	0.94	1.63	\$
	61001-5140	—	Stainless Steel	16	0.008	4.81	1.59	1.37	.88	0.94	1.63	\$
3	61003-5116	1-056-214-00	Cast Iron	16	0.008	4.81	1.59	1.37	.88	0.94	1.63	\$
	61003-5140	1-056-914-00	Stainless Steel	16	0.008	4.81	1.59	1.37	.88	0.94	1.63	\$
6	61006-5116	1-056-224-00	Cast Iron	17	0.008	4.81	1.59	1.37	.88	0.94	1.63	\$
	61006-5140	1-056-924-00	Stainless Steel	17	0.008	4.81	1.59	1.37	.88	0.94	1.63	\$
10	62010-5116	1-056-234-00	Cast Iron	17	0.013	4.81	1.59	1.37	.88	0.94	1.63	\$
	62010-5140	1-056-934-00	Stainless Steel	17	0.013	4.81	1.59	1.37	.88	0.94	1.63	\$
15	63015-5116	1-056-244-00	Cast Iron	18	0.019	5.13	1.90	1.93	1.19	0.94	1.94	\$
	63015-5140	1-056-944-00	Stainless Steel	18	0.019	5.13	1.90	1.93	1.19	0.94	1.94	\$
20	63020-5116	1-056-254-00	Cast Iron	18	0.019	5.13	1.90	1.93	1.19	0.94	1.94	\$
	63020-5140	1-056-954-00	Stainless Steel	18	0.019	5.13	1.90	1.93	1.19	0.94	1.94	\$
25	64025-5116	1-056-264-00	Cast Iron	19	0.022	5.44	2.05	1.83	1.34	1.56	2.25	\$
	64025-5140	1-056-964-00	Stainless Steel	19	0.022	5.44	2.05	1.83	1.34	1.56	2.25	\$

NOTE 1: Hub length and location differ.

Stearns® is a Registered Trademark of Rexnord Corporation

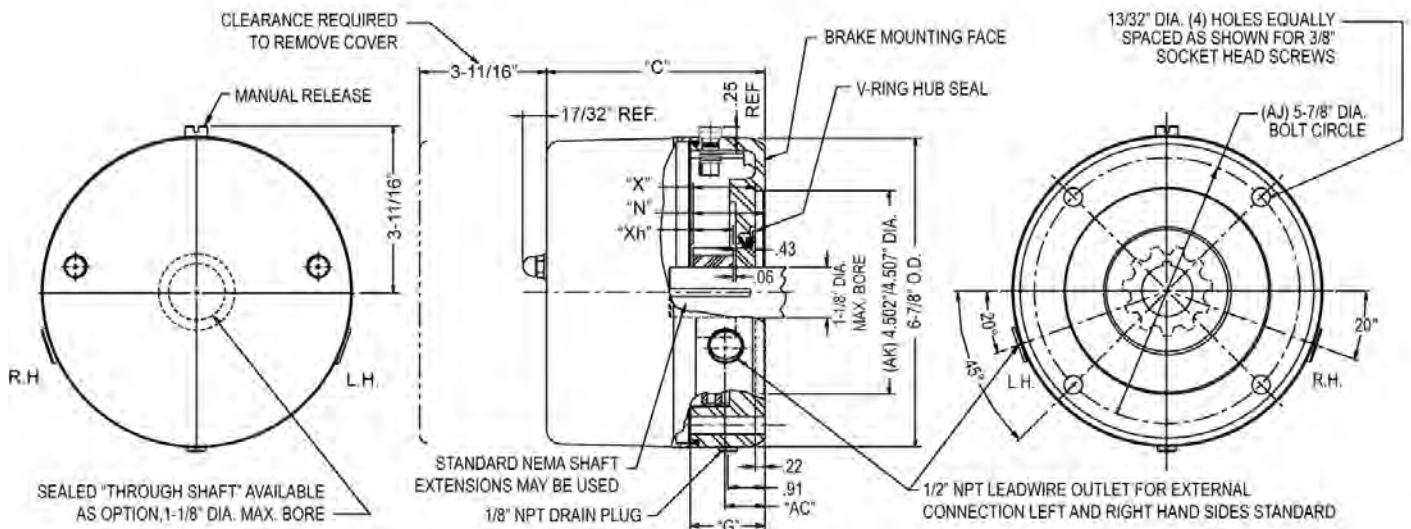

60 Series Double C Face

NEMA Frame Sizes 56C, 143TC, 145TC
Torque Ratings: 1.5 to 20 lb-ft

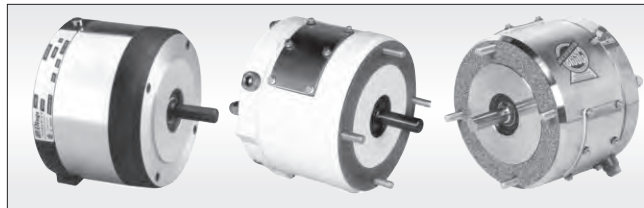

[BACK TO TABLE
OF CONTENTS](#)

Specifications:

Reaction Time: 15-20 milliseconds (release and set)
 AK: 4.5" Register
 AJ: 5.88" Bolt Circle
 Thermal Capacity: 6 HPS/MIN
 Maximum RPM: 3600
 CSA File #LR13814
 Coil insulation:
 Class B : 1.5, 3, 10 & 15 lb-ft brakes (Class H optional)
 Class H : 6 & 20 lb-ft brakes

Instructions and Parts Manual:

NEMA 2 = BK4650
 NEMA 4 = BK4652
 NEMA 4X aluminum = BK4646
 NEMA 4X stainless steel = BK4651

Design Features:

Direct acting design with no linkages to break
 One moving part for longer life
 Torque adjustable for specific applications
 Splined hub
 Plated internal parts - RoHS compliant
 Spring set, electrically released
 Lead wires for internal or conduit connections
 Manual release, automatic reset
 All position brake available

Enclosure Types:

Dripproof NEMA 2, CSA 2, IP41

Aluminum bracket & housing with steel wrap cover
 Exterior Paint: Gray enamel
 Nameplate: Thermally printed adhesive label

Waterproof/Dusttight Enclosure NEMA 4, CSA 4, IP56

Aluminum bracket and housing with stainless steel caps
 Exterior Paint: Gray enamel
 Nameplate: Stainless steel

Washdown Enclosure NEMA 4X, CSA 4, IP56

WHITE BISSC

Aluminum bracket and housing with stainless steel caps
 and FDA Approved white epoxy paint

BISSC Certified Authorization #695

Nameplate: Stainless steel

STAINLESS STEEL BISSC

300 Series Stainless steel bracket, housing and caps

BISSC Certified Authorization #695

Nameplate: Stainless steel

Brake Model Number Definition

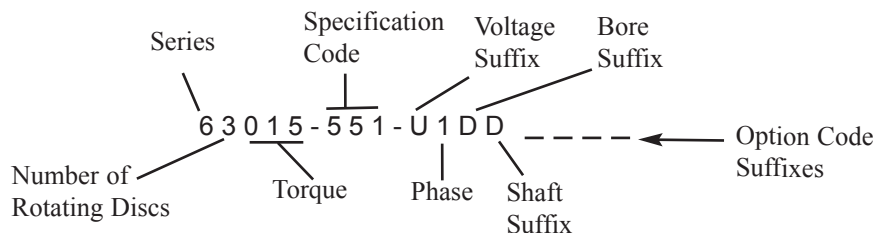

Standard AC Voltages (single phase only):	
Suffix	Voltage
Y	110/220V, 50Hz
U	230/460V, 60 Hz or 190/380V, 50 Hz
5	208-230/460V, 60 Hz
R	115/230V, 60 Hz
1	115/208-230V, 60 Hz
T	220/440V, 60 Hz
P	575V, 60 Hz

Special voltages available.

Optional DC Voltages (See price for DC modification):		
Suffix	Voltage	List Price Adder
A	12	\$
B	24	\$
C	36	\$
D	48	\$
7	76	\$
E	95	\$
H	115	\$
M	230	\$

Special voltages available.

Available Options:	Suffix
Foot Mounting Bracket	F
Heavy-Duty Rotating Friction Disc with Hardened Steel Hub	H
Marine/Maritime Duty with MIL-SPEC paint per TT-P-645 & MIL-DTL-15090	M
Marine/Maritime Duty	N
Tropical Protection	P
Internal Space Heater	R
Stainless Steel Stationary Disc	S
Class H Insulation	Q
Vertical Mounting	
Vertical Over, or above motor	VO
Vertical Under, or below motor	VU
Micro-Switch Warning	XS

Refer to pages 51-56 for option descriptions & pricing.

Standard Hub Bore & Shaft Sizes:		
Suffix	Size	Keyway
D	5/8"	3/16" x 3/32"
F	7/8"	3/16" x 3/32"

Special bore sizes available.

Torque lb-ft	Dings Model #	Replacement for Stearns® Model (NOTE1)	Enclosure	Construction	Wt. Lbs.	Inertia Wk ² lb-ft ²	Dimensions in inches				List Price
							C	X		AC	
								1-Piece Shaft*	2-Piece Shaft*		
1.5	61001-551	1-056-701-0X	NEMA 2	Cast Aluminum	11	0.006	4.94	0.81	0.88	0.59	\$
	61001-5153	1-056-702-0X	NEMA 4	Cast Aluminum	11	0.006	4.94	0.81	0.88	0.59	\$
	61001-5155	1-056-704-0X	NEMA 4X	Cast Aluminum	11	0.006	4.94	0.81	0.88	0.59	\$
	61001-5145	—	NEMA 4X	Stainless Steel	20	0.006	5.07	0.81	0.88	0.63	\$
3	61003-551	1-056-711-0X	NEMA 2	Cast Aluminum	11	0.006	4.94	0.81	0.88	0.59	\$
	61003-5153	1-056-712-0X	NEMA 4	Cast Aluminum	11	0.006	4.94	0.81	0.88	0.59	\$
	61003-5155	1-056-714-0X	NEMA 4X	Cast Aluminum	11	0.006	4.94	0.81	0.88	0.59	\$
	61003-5145	1-056-71S-0X	NEMA 4X	Stainless Steel	20	0.006	5.07	0.81	0.88	0.63	\$
6	61006-551	1-056-721-0X	NEMA 2	Cast Aluminum	12	0.006	4.94	0.81	0.88	0.59	\$
	61006-5153	1-056-722-0X	NEMA 4	Cast Aluminum	12	0.006	4.94	0.81	0.88	0.59	\$
	61006-5155	1-056-724-0X	NEMA 4X	Cast Aluminum	12	0.006	4.94	0.81	0.88	0.59	\$
	61006-5145	1-056-72S-0X	NEMA 4X	Stainless Steel	21	0.006	5.07	0.81	0.88	0.63	\$
10	62010-551	1-056-731-0X	NEMA 2	Cast Aluminum	12	0.010	4.94	0.81	—	0.59	\$
	62010-5153	1-056-732-0X	NEMA 4	Cast Aluminum	12	0.010	4.94	0.81	—	0.59	\$
	62010-5155	1-056-734-0X	NEMA 4X	Cast Aluminum	12	0.010	4.94	0.81	—	0.59	\$
	62010-5145	1-056-73S-0X	NEMA 4X	Stainless Steel	21	0.010	5.07	0.81	—	0.63	\$
15	63015-551	1-056-741-0X	NEMA 2	Cast Aluminum	13	0.014	5.31	1.19	—	0.87	\$
	63015-5153	1-056-742-0X	NEMA 4	Cast Aluminum	13	0.014	5.31	1.19	—	0.87	\$
	63015-5155	1-056-744-0X	NEMA 4X	Cast Aluminum	13	0.014	5.31	1.19	—	0.87	\$
	63015-5145	1-056-74S-0X	NEMA 4X	Stainless Steel	23	0.014	5.44	1.19	—	0.94	\$
20	63020-551	1-056-751-0X	NEMA 2	Cast Aluminum	13	0.014	5.31	1.19	—	0.87	\$
	63020-5153	1-056-752-0X	NEMA 4	Cast Aluminum	13	0.014	5.31	1.19	—	0.87	\$
	63020-5155	1-056-754-0X	NEMA 4X	Cast Aluminum	13	0.014	5.31	1.19	—	0.87	\$
	63020-5145	1-056-75S-0X	NEMA 4X	Stainless Steel	23	0.014	5.44	1.19	—	0.94	\$

NOTE 1: Hub length and location differ.

*Brakes rated 1.5 through 6 lb-ft include “2-piece shaft” as standard. This includes a separate hub and shaft.
The “1-piece” hub and shaft is available as a modification.
Brakes rated 10 through 20 lb-ft have a 1-piece hub and shaft.

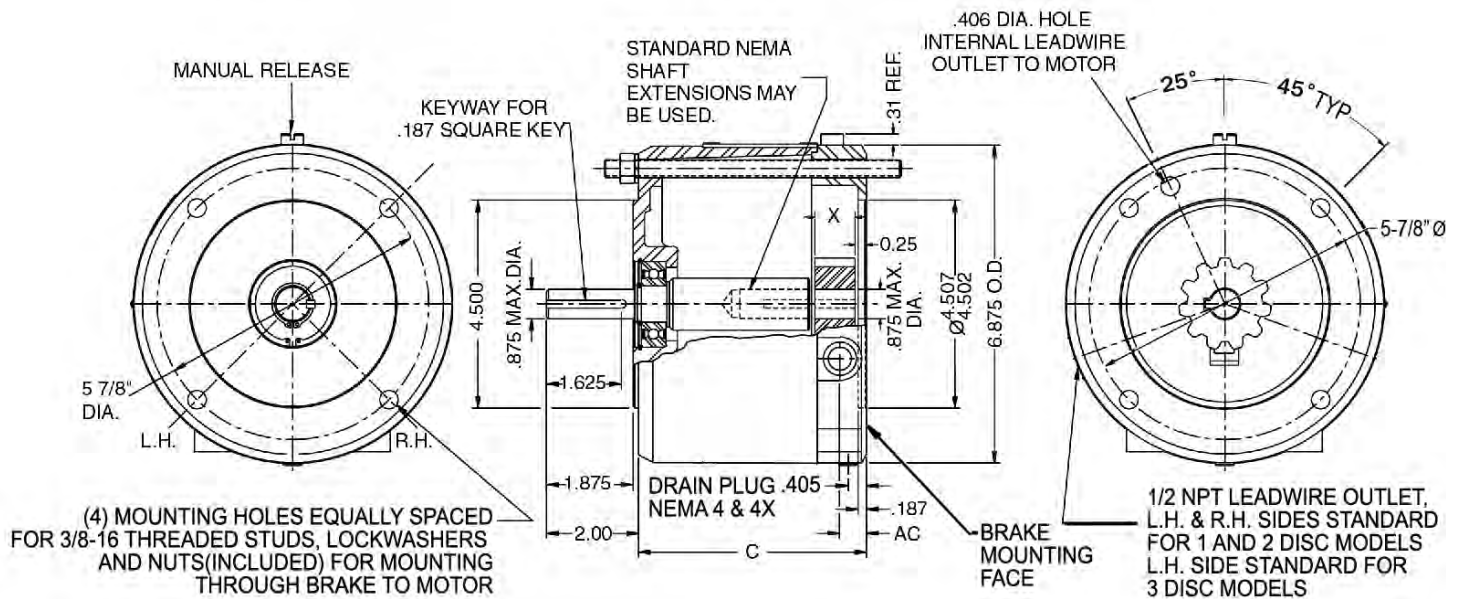

Stearns® is a Registered Trademark of Rexnord Corporation

1-70 Series End Mount

NEMA Frame Sizes 182TC through 256TC/UC
Torque Ratings: 1.5 to 25 lb-ft

[BACK TO TABLE OF CONTENTS](#)

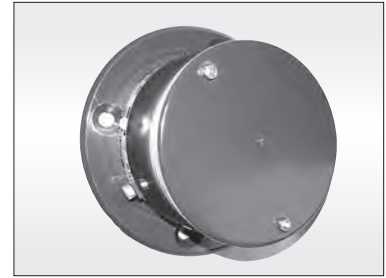

Specifications:

- Reaction Time: 15-20 milliseconds (release and set)
- AK: 8.5" Register
- AJ: 7.25" Bolt Circle
- Thermal Capacity: 6 HPS/MIN
- Maximum RPM: 3600
- CSA File #LR13814
- Coil insulation:
 - 1.5 – 15 lb-ft Class B Standard, Class H Optional
 - 20 & 25 lb-ft Class H Standard
- Instructions and Parts Manual: BK4755

Design Features:

- Direct acting design with no linkages to break
- One moving part for longer life
- Torque adjustable for specific applications
- Splined hub
- Plated internal parts - RoHS compliant
- Spring set, electrically released
- Lead wires for internal or conduit connections
- Manual release, automatic reset
- All position brake available

Enclosure Types:

Dripproof Enclosure NEMA 2, CSA 2, IP41

- Stamped steel cover with aluminum bracket & cast iron adaptor, 1.5 - 20 lb-ft
- Stamped steel cover with cast iron bracket & adaptor, 25 lb-ft
- External paint: Red primer
- Nameplate: Thermally printed adhesive label (pre-masked)

Brake Model Number Description

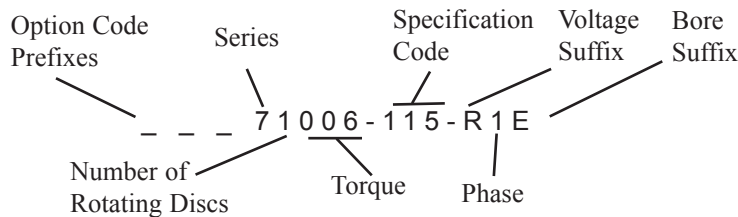

Standard AC Voltages (single phase only):	
Suffix	Voltage
Y	110/220V, 50Hz
U	230/460V, 60 Hz or 190/380V, 50 Hz
5	208-230/460V, 60 Hz
R	115/230V, 60 Hz
1	115/208-230V, 60 Hz
T	220/440V, 60 Hz
P	575V, 60 Hz
Special voltages available.	

Optional DC Voltages (See price for DC modification):		
Suffix	Voltage	List Price Adder
A	12	\$
B	24	\$
C	36	\$
D	48	\$
7	76	\$
E	95	\$
H	115	\$
M	230	\$
Special voltages available.		

Available Options:	Prefix
Heavy-Duty Rotating Friction Disc with Hardened Steel Hub	H
Marine/Maritime Duty with MIL-SPEC paint per TT-P-645 & MIL-DTL-15090	M
Marine/Maritime Duty	N
Tropical Protection	P
Internal Space Heater	R
Stainless Steel Stationary Disc	S
Through Shaft	T
Class H Insulation	Q
Vertical Mounting	
Vertical Over, or above motor	VO
Vertical Under, or below motor	VU
Micro-Switch Warning	XS
Refer to pages 51-56 for option descriptions & pricing.	

Standard Hub Bore Sizes:		
Suffix	Size	Keyway
D	5/8"	3/16" x 3/32"
F	7/8"	3/16" x 3/32"
H	1 1/8"	1/4" x 1/8"
Special bore sizes available.		

Torque lb-ft	Model #	Replacement for Stearns® Model (NOTE1)	Enclosure	Construction	Wt. Lbs.	Inertia WK ² lb-ft ²	Dimensions				List Price
							C	N	X	AC	
1.5	71001-115	-	NEMA 2	Aluminum/Steel	10	0.006	4.57	1.69	0.88	1.21	\$
3	71003-115	-	NEMA 2	Aluminum/Steel	10	0.006	4.57	1.69	0.88	1.21	\$
6	71006-115	-	NEMA 2	Aluminum/Steel	10	0.006	4.57	1.69	0.88	1.21	\$
10	72010-115	1-056-531-00	NEMA 2	Aluminum/Steel	10	0.010	4.94	1.87	1.19	1.50	\$
15	73015-115	1-056-541-00	NEMA 2	Aluminum/Steel	11	0.015	4.94	1.87	1.19	1.50	\$
20	73020-115	1-056-551-00	NEMA 2	Aluminum/Steel	11	0.015	4.94	1.87	1.19	1.50	\$
25	74025-115	1-056-561-00	NEMA 2	Cast Iron/Steel	18	0.020	5.63	2.44	1.34	2.19	\$

NOTE 1: Hub length and location differ.

Stearns® is a registered trademark of Rexnord Corporation.

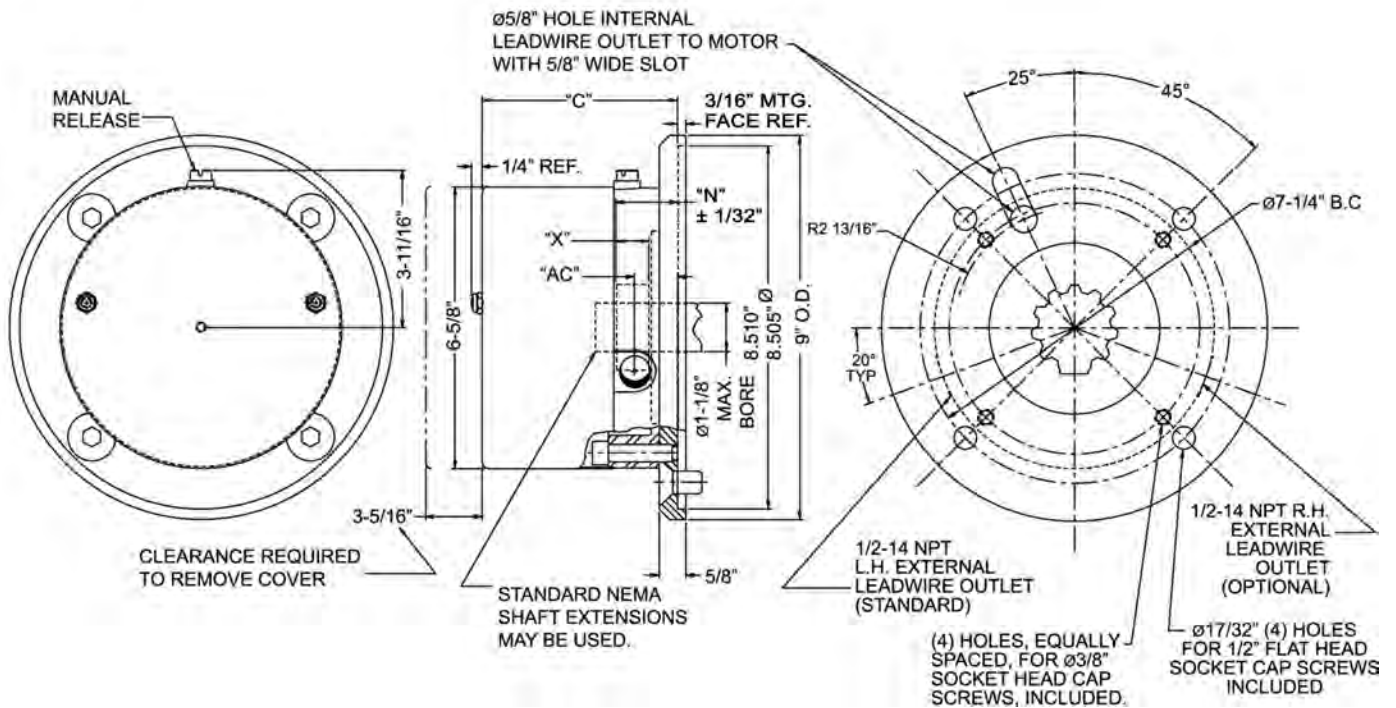

70 Series End Mount

8700 Style

NEMA Frame Sizes 182TC through 256TC/UC

Torque Ratings: 10 to 105 lb-ft

Dripproof NEMA 2, CSA 2, IP43

[BACK TO TABLE OF CONTENTS](#)



Direct replacement for Stearns® brakes

70 Series Specifications:

- Reaction Time: 20-25 milliseconds (release and set)
- AK: 8.5" Register
- AJ: 7.25" Bolt Circle
- Maximum RPM: 3600
- CSA File #LR13814
- Coil insulation: Class H standard
- External paint: Red primer
- Lead wires: Internal or conduit connections
- Nameplate: Thermally printed adhesive label (pre-masked)
- Instructions and Parts Manual:
 - Dings Standard = BK4772
 - Stearns Replacement = BK4772S

Design Features:

- RoHS compliant
- No disassembly required for mounting
- Direct acting design with no linkages to break
- Torque adjustable for specific applications
- External manual release with automatic reset
- One moving part for longer life
- Splined hub
- Spring set, electrically released
- All position brake available

Brake Model Number Definition

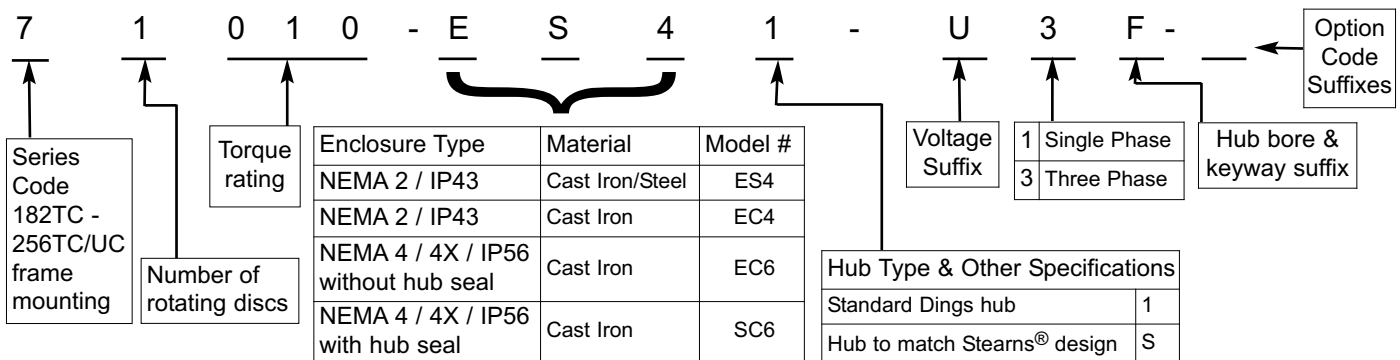

Standard Voltages	
(Single or three Phase):	
Suffix	Voltage
Y	110/220V, 50Hz
U	230/460V, 60 Hz or 190/380V, 50 Hz
5	208-230/460V, 60 Hz
R	115/230V, 60 Hz
1	115/208-230V, 60 Hz
T	220/440V, 60 Hz
P	575V, 60 Hz
Special voltages available.	

Standard Hub Bore Sizes:		
Suffix	Size	Keyway
F	7/8"	3/16" x 3/32"
H	1 1/8"	1/4" x 1/8"
J	1 1/4"	1/4" x 1/8"
K	1 3/8"	5/16" x 5/32"
M	1 5/8"	3/8" x 3/16"
Special bore sizes available.		

Available Options:	Suffix
Adapter to Larger Frame Size(s)	A
Reverse Adapter	AB
Foot Mounting Bracket	F
Heavy-Duty Rotating Friction Disc	H
Marine/Maritime Duty with MIL-SPEC paint per TT-P-645 & MIL-DTL-15090	M
Marine/Maritime Duty	N
Tropical Protection	P
Internal Space Heater	R
Stainless Steel Stationary Disc	S
Through Shaft	T
Vertical Mounting, over motor	VO
Vertical Mounting, under motor	VU
Micro-Switch Warning	XS
Refer to pages 51-56 for option descriptions & pricing.	

NEMA 2 / IP43 Enclosure DINGS STANDARD

Torque lb-ft	Model # Dings Standard	Replaces Dings 2-post Brake Models	Replaces Dings 4-post Brake Models	Construction	Weight lbs.	Thermal Capacity HPS/Min	Inertia WK ² Lb-Ft ²	Dimensions in inches				List Price
								C	"N" Hub Location	"X" Hub Length	AC	
10	71010-ES41	6-71010-96	6-71010-97	Cast Iron/Steel	30	10	.047	6.91	1.50	1.00	1.13	\$
	71010-EC41	R71010	6-71010-55	Cast Iron	41	10	.047	6.91	1.50	1.00	1.13	\$
15	71015-ES41	6-71015-96	6-71015-97	Cast Iron/Steel	30	10	.047	6.91	1.50	1.00	1.13	\$
	71015-EC41	R71015	6-71015-55	Cast Iron	41	10	.047	6.91	1.50	1.00	1.13	\$
25	72025-ES41	6-72025-96	6-72025-97	Cast Iron/Steel	32	11	.075	6.91	2.00	1.50	1.13	\$
	72025-EC41	R72025	6-72025-55	Cast Iron	43	11	.075	6.91	2.00	1.50	1.13	\$
35	72035-ES41	6-72035-96	6-72035-97	Cast Iron/Steel	32	11	.075	6.91	2.00	1.50	1.13	\$
	72035-EC41	R72035	6-72035-55	Cast Iron	43	11	.075	6.91	2.00	1.50	1.13	\$
50	73050-ES41	6-73050-96	6-73050-97	Cast Iron/Steel	37	12	.103	7.47	2.50	2.00	1.69	\$
	73050-EC41	R73050	6-73050-55	Cast Iron	48	12	.103	7.47	2.50	2.00	1.69	\$
75	74075-ES41	6-74075-96	6-74075-97	Cast Iron/Steel	42	13	.131	8.03	3.00	2.50	2.25	\$
	74075-EC41	R74075	6-74075-55	Cast Iron	53	13	.131	8.03	3.00	2.50	2.25	\$
105	74105-ES41	NEW	NEW	Cast Iron/Steel	42	13	.131	8.03	3.00	2.50	2.25	\$
	74105-EC41	NEW	NEW	Cast Iron	53	13	.131	8.03	3.00	2.50	2.25	\$

NEMA 2 / IP43 Enclosure STEARNS® REPLACEMENT

Torque lb-ft	Model # Stearns Replacement	Direct Drop-in replacement for Stearns® Model	Construction	Weight lbs.	Thermal Capacity HPS/Min	Inertia WK ² Lb-Ft ²	Dimensions in inches				List Price
							C	"N" Hub Location	"X" Hub Length	AC	
10	71010-ES4S	1-087-011-00	Cast Iron/Steel	30	10	.045	6.91	1.13	1.00	1.13	\$
	71010-EC4S	N/A	Cast Iron	41	10	.045	6.91	1.13	1.00	1.13	\$
15	71015-ES4S	1-087-021-00	Cast Iron/Steel	30	10	.045	6.91	1.13	1.00	1.13	\$
	71015-EC4S	N/A	Cast Iron	41	10	.045	6.91	1.13	1.00	1.13	\$
25	71025-ES4S	1-087-031-00	Cast Iron/Steel	30	11	.074	6.91	1.13	1.00	1.13	\$
	71025-EC4S	N/A	Cast Iron	41	11	.074	6.91	1.13	1.00	1.13	\$
35	72035-ES4S	1-087-041-00	Cast Iron/Steel	32	11	.074	6.91	1.13	1.00	1.13	\$
	72035-EC4S	N/A	Cast Iron	43	11	.074	6.91	1.13	1.00	1.13	\$
50	72050-ES4S	1-087-051-00	Cast Iron/Steel	32	12	.077	6.91	1.63	1.50	1.13	\$
	72050-EC4S	N/A	Cast Iron	43	12	.077	6.91	1.63	1.50	1.13	\$
75	73075-ES4S	1-087-061-00	Cast Iron/Steel	37	13	.077	7.47	1.63	1.50	1.69	\$
	73075-EC4S	N/A	Cast Iron	48	13	.077	7.47	1.63	1.50	1.69	\$
105	74105-ES4S	1-087-081-00	Cast Iron/Steel	42	13	.136	8.03	2.13	2.00	2.25	\$
	74105-EC4S	N/A	Cast Iron	53	13	.136	8.03	2.13	2.00	2.25	\$

Stearns® is a Registered Trademark of Rexnord Corporation

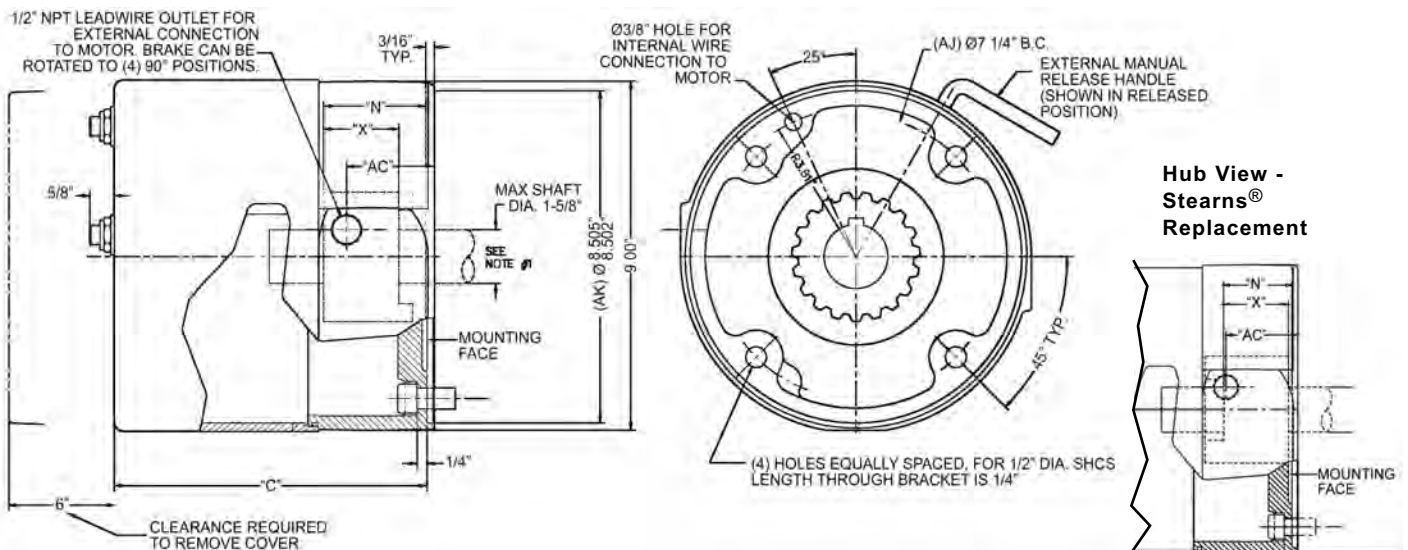

70 Series End Mount 8700 Style

NEMA Frame Sizes 182TC through 256TC/UC

Torque Ratings: 10 to 105 lb-ft

NEMA 4 / 4X, CSA 4, IP56
without hub seal for Non-TEFC applications

[BACK TO TABLE
OF CONTENTS](#)



Direct replacement for Stearns® brakes

NEMA 4 / 4X Non-TEFC Specifications:

Reaction Time: 20-25 milliseconds (release and set)

AK: 8.5" Register

AJ: 7.25" Bolt Circle

Maximum RPM: 3600

CSA File #LR13814

Coil insulation: Class H standard

Enclosure: Cast iron

External paint: NEMA 4, Red primer

NEMA 4X, FDA approved white epoxy

Lead wires: Internal or conduit connections

Nameplate: Stamped stainless steel

Instructions and Parts Manual:

NEMA 4 = BK4773

NEMA 4X = BK4774

Design Features:

RoHS compliant

No disassembly required for mounting

Direct acting design with no linkages to break

Torque adjustable for specific applications

External manual release with automatic reset

One moving part for longer life

Splined hub

Spring set, electrically released

All position brake available

Brake Model Number Definition

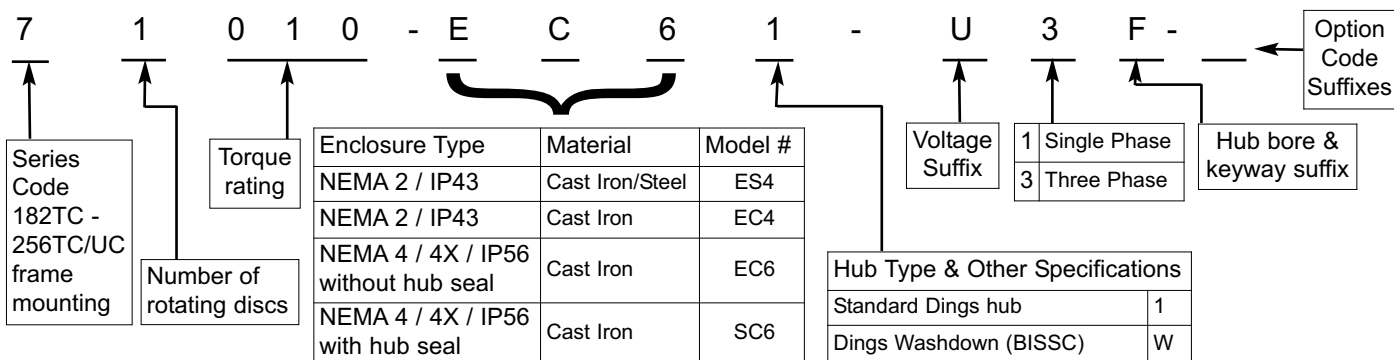

Standard Voltages	
(Single or three Phase):	
Suffix	Voltage
Y	110/220V, 50Hz
U	230/460V, 60 Hz or 190/380V, 50 Hz
5	208-230/460V, 60 Hz
R	115/230V, 60 Hz
1	115/208-230V, 60 Hz
T	220/440V, 60 Hz
P	575V, 60 Hz
Special voltages available.	

Standard Hub Bore Sizes:		
Suffix	Size	Keyway
F	7/8"	3/16" x 3/32"
H	1 1/8"	1/4" x 1/8"
J	1 1/4"	1/4" x 1/8"
K	1 3/8"	5/16" x 5/32"
M	1 5/8"	3/8" x 3/16"
Special bore sizes available.		

Available Options:	Prefix
Adapter to Larger Frame Size(s)	A
Reverse Adapter	AB
Foot Mounting Bracket	F
Heavy-Duty Rotating Friction Disc	H
Marine/Maritime Duty with MIL-SPEC paint per TT-P-645 & MIL-DTL-15090	M
Marine/Maritime Duty	N
Tropical Protection	P
Internal Space Heater	R
Stainless Steel Stationary Disc	S
Through Shaft	T
Vertical Mounting, over motor	VO
Vertical Mounting, under motor	VU
Micro-Switch Warning	XS
Refer to pages 51-56 for option descriptions & pricing.	

NEMA 4 / IP56 Enclosure *without hub seal* for non-TEFC applications

[BACK TO TABLE
OF CONTENTS](#)

Cast Iron Construction

Torque lb-ft	Model # Dings Standard	Replaces Dings 2-post Brake Models	Replaces Dings 4-post Brake Models	Weight lbs.	Thermal Capacity HPS/Min	Dimensions in inches					List Price
						Inertia WK ² Lb-Ft ²	C	N Hub Location	X Hub Length	AC	
10	71010-EC61	R71010-37	6-71010-58	41	10	.047	6.91	1.50	1.00	1.13	\$
15	71015-EC61	R71015-37	6-71015-58	41	10	.047	6.91	1.50	1.00	1.13	\$
25	72025-EC61	R72025-37	6-72025-58	43	11	.075	6.91	2.00	1.50	1.13	\$
35	72035-EC61	R72035-37	6-72035-58	43	11	.075	6.91	2.00	1.50	1.13	\$
50	73050-EC61	R73050-37	6-73050-58	48	12	.103	7.47	2.50	2.00	1.69	\$
75	74075-EC61	R74075-37	6-74075-58	53	13	.130	8.03	3.00	2.50	2.25	\$
105	74105-EC61	NEW	NEW	53	13	.130	8.03	3.00	2.50	2.25	\$

WASHDOWN NEMA 4X / IP56 Enclosure *without hub seal* for non-TEFC applications

Cast Iron Construction

Torque lb-ft	Model # Dings Standard	Replaces Dings 2-post Brake Models	Replaces Dings 4-post Brake Models	Weight lbs.	Thermal Capacity HPS/Min	Dimensions in inches					List Price
						Inertia WK ² Lb-Ft ²	C	N Hub Location	X Hub Length	AC	
10	71010-EC6W	R71010-91	6-71010-92	41	10	.047	6.91	1.50	1.00	1.13	\$
15	71015-EC6W	R71015-91	6-71015-92	41	10	.047	6.91	1.50	1.00	1.13	\$
25	72025-EC6W	R72025-91	6-72025-92	43	11	.075	6.91	2.00	1.50	1.13	\$
35	72035-EC6W	R72035-91	6-72035-92	43	11	.075	6.91	2.00	1.50	1.13	\$
50	73050-EC6W	R73050-91	6-73050-92	48	12	.103	7.47	2.50	2.00	1.69	\$
75	74075-EC6W	R74075-91	6-74075-92	53	13	.130	8.03	3.00	2.50	2.25	\$
105	74105-EC6W	NEW	NEW	53	13	.130	8.03	3.00	2.50	2.25	\$

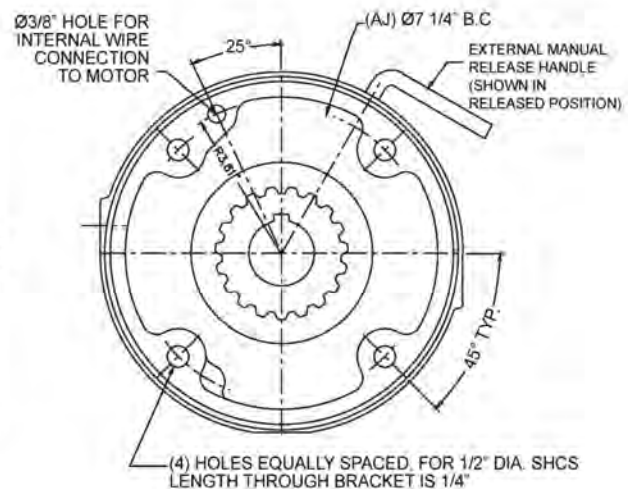
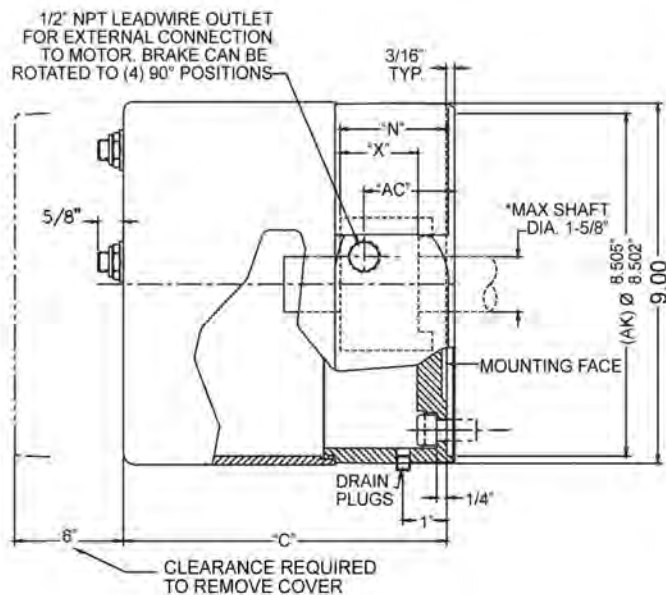

70 Series End Mount

8700 Style

NEMA Frame Sizes 182TC through 256TC/UC

Torque Ratings: 10 to 105 lb-ft

NEMA 4, CSA 4, IP56* with hub seal for TEFC applications

*To obtain full IP56 protection, the customer shaft, hub bore, key and keyway's mating surface(s) must be sealed to meet IP56. Considerations should be reviewed to appropriately seal mounting hardware as well. Contact factory for details and/or assistance.

[BACK TO TABLE OF CONTENTS](#)



Direct replacement for Stearns® brakes

NEMA 4 TEFC Specifications:

- Reaction Time: 20-25 milliseconds (release and set)
- AK: 8.5" Register / AJ: 7.25" Bolt Circle
- Maximum RPM: 3600
- CSA File #LR13814
- Coil insulation: Class H standard
- Enclosure: Cast iron
- External paint: Red primer
- Lead wires: Conduit connections
- Nameplate: Stamped stainless steel
- Instructions and Parts Manual:
 - Dings Standard = BK4773
 - Stearns Replacement = BK4773S

Design Features:

- RoHS compliant
- No disassembly required for mounting
- Direct acting design with no linkages to break
- Torque adjustable for specific applications
- External manual release with automatic reset
- One moving part for longer life
- Splined hub
- Spring set, electrically released
- All position brake available

Brake Model Number Definition

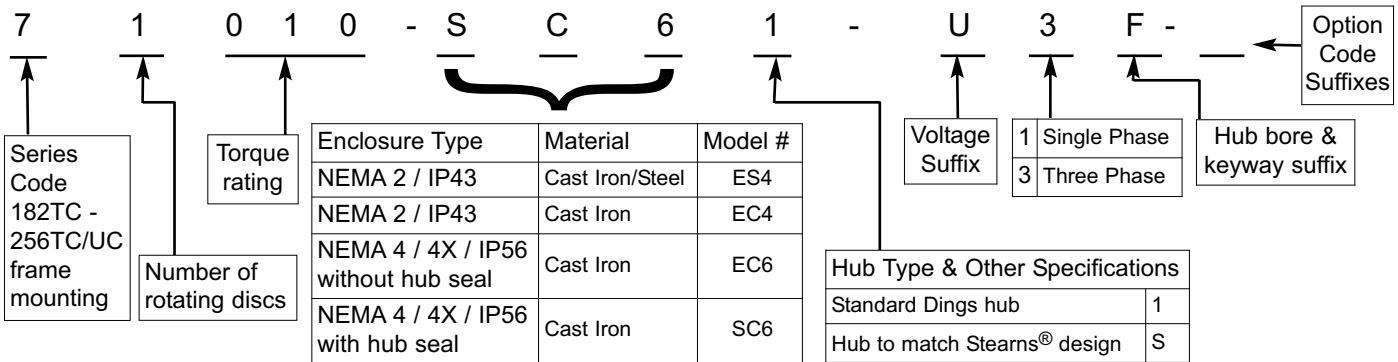

Standard Voltages	
(Single or three phase):	
Suffix	Voltage
Y	110/220V, 50Hz
U	230/460V, 60 Hz or 190/380V, 50 Hz
5	208-230/460V, 60 Hz
R	115/230V, 60 Hz
1	115/208-230V, 60 Hz
T	220/440V, 60 Hz
P	575V, 60 Hz
Special voltages available.	

Standard Hub Bore Sizes:		
Suffix	Size	Keyway
F	7/8"	3/16" x 3/32"
H	1 1/8"	1/4" x 1/8"
J	1 1/4"	1/4" x 1/8"
K	1 3/8"	5/16" x 5/32"
M	1 5/8"	3/8" x 3/16"
Special bore sizes available.		

Available Options:	Prefix
Adapter to Larger Frame Size(s)	A
Reverse Adapter	AB
Foot Mounting Bracket	F
Heavy-Duty Rotating Friction Disc	H
Marine/Maritime Duty with MIL-SPEC paint per TT-P-645 & MIL-DTL-15090	M
Marine/Maritime Duty	N
Tropical Protection	P
Internal Space Heater	R
Stainless Steel Stationary Disc	S
Through Shaft	T
Vertical Mounting, over motor	VO
Vertical Mounting, under motor	VU
Micro-Switch Warning	XS

Refer to pages 51-56 for option descriptions & pricing.

NEMA 4 / IP56 Enclosure with hub seal DINGS STANDARD

[BACK TO TABLE OF CONTENTS](#)

Cast Iron Construction

Torque lb-ft	Model # Dings Standard	Replaces Dings 2-post Brake Models	Replaces Dings 4-post Brake Models	Weight lbs.	Thermal Capacity HPS/Min	Dimensions in inches					List Price
						Inertia WK ² Lb-Ft ²	C	N Hub Location	X Hub Length	AC	
10	71010-SC61	R71010-4	6-71010-57	41	10	.047	6.91	1.50	1.00	1.13	\$
15	71015-SC61	R71015-4	6-71015-57	41	10	.047	6.91	1.50	1.00	1.13	\$
25	72025-SC61	R72025-4	6-72025-57	43	11	.075	6.91	2.00	1.50	1.13	\$
35	72035-SC61	R72035-4	6-72035-57	43	11	.075	6.91	2.00	1.50	1.13	\$
50	73050-SC61	R73050-4	6-73050-57	48	12	.103	7.47	2.50	2.00	1.69	\$
75	74075-SC61	R74075-4	6-74075-57	53	13	.130	8.03	3.00	2.50	2.25	\$
105	74105-SC61	NEW	NEW	53	13	.130	8.03	3.00	2.50	2.25	\$

NEMA 4 / IP56 Enclosure with hub seal STEARNS® REPLACEMENT

Cast Iron Construction

Stearns® Replacement	Torque lb-ft	Dings Model # Stearns® Replacement	Direct Drop-in replacement for Stearns® Model	Weight lbs.	Thermal Capacity HPS/Min	Inertia WK ² Lb-Ft ²	Dimensions in inches				List Price
							C	N Hub Location	X Hub Length	AC	
	10	71010-SC6S	1-087-012-00	41	10	.045	6.91	1.13	1.00	1.13	\$
	15	71015-SC6S	1-087-022-00	41	10	.045	6.91	1.13	1.00	1.13	\$
	25	71025-SC6S	1-087-032-00	41	11	.045	6.91	1.13	1.00	1.13	\$
	35	72035-SC6S	1-087-042-00	43	11	.074	6.91	1.13	1.00	1.13	\$
	50	72050-SC6S	1-087-052-00	43	12	.077	6.91	1.63	1.50	1.13	\$
	75	73075-SC6S	1-087-062-00	48	13	.105	7.47	1.63	1.50	1.69	\$
	105	74105-SC6S	1-087-082-00	53	13	.136	8.03	2.13	2.00	2.25	\$

Stearns® is a Registered Trademark of Rexnord Corporation

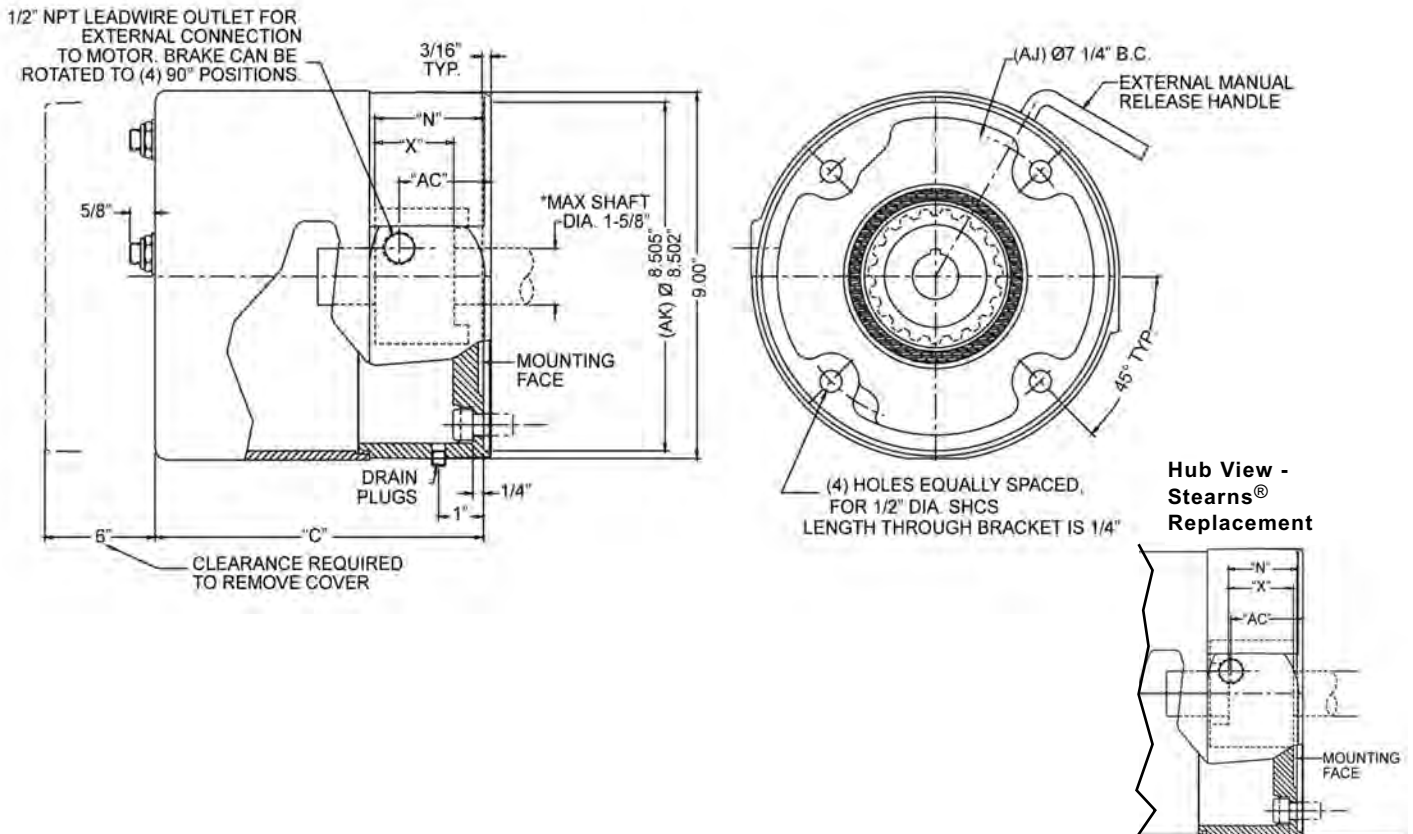

70 Series End Mount

[BACK TO TABLE
OF CONTENTS](#)



Direct replacement for Stearns® brakes

8700 Style

NEMA Frame Sizes 182TC through 256TC/UC

Torque Ratings: 10 to 105 lb-ft

NEMA 4X, CSA 4, IP56* with hub seal for TEFC applications

*To obtain full IP56 protection, the customer shaft, hub bore, key and keyway's mating surface(s) must be sealed to meet IP56. Considerations should be reviewed to appropriately seal mounting hardware as well. Contact factory for details and/or assistance.

NEMA 4X TEFC Specifications:

Reaction Time: 20-25 milliseconds (release and set)

AK: 8.5" Register / AJ: 7.25" Bolt Circle

Maximum RPM: 3600

CSA File #LR13814

Coil insulation: Class H standard

Enclosure: Cast iron

External paint: FDA approved white epoxy

Lead wires: Conduit connections

Nameplate: Stamped stainless steel

Instructions and Parts Manual:

Dings Standard = BK4774

Stearns Replacement = BK4774S

Design Features:

RoHS compliant

No disassembly required for mounting

Direct acting design with no linkages to break

Torque adjustable for specific applications

External manual release with automatic reset

One moving part for longer life

Splined hub

Spring set, electrically released

All position brake available

Brake Model Number Definition

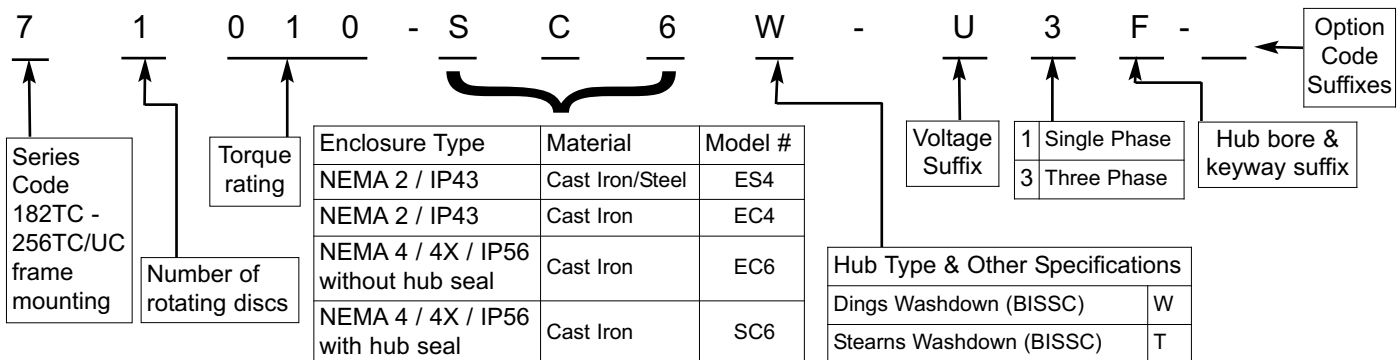

Standard Voltages	
(Single or three phase):	
Suffix	Voltage
Y	110/220V, 50Hz
U	230/460V, 60 Hz or 190/380V, 50 Hz
5	208-230/460V, 60 Hz
R	115/230V, 60 Hz
1	115/208-230V, 60 Hz
T	220/440V, 60 Hz
P	575V, 60 Hz
Special voltages available.	

Standard Hub Bore Sizes:		
Suffix	Size	Keyway
F	7/8"	3/16" x 3/32"
H	1 1/8"	1/4" x 1/8"
J	1 1/4"	1/4" x 1/8"
K	1 3/8"	5/16" x 5/32"
M	1 5/8"	3/8" x 3/16"
Special bore sizes available.		

Available Options:	Prefix
Adapter to Larger Frame Size(s)	A
Reverse Adapter	AB
Foot Mounting Bracket	F
Heavy-Duty Rotating Friction Disc	H
Marine/Maritime Duty with MIL-SPEC paint per TT-P-645 & MIL-DTL-15090	M
Marine/Maritime Duty	N
Tropical Protection	P
Internal Space Heater	R
Stainless Steel Stationary Disc	S
Through Shaft	T
Vertical Mounting, over motor	VO
Vertical Mounting, under motor	VU
Micro-Switch Warning	XS
Refer to pages 51-56 for option descriptions & pricing.	

WASHDOWN NEMA 4X / IP56 Enclosure with hub seal DINGS STANDARD

Cast Iron Construction

[BACK TO TABLE OF CONTENTS](#)

Torque lb-ft	Model # Dings Standard	Replaces Dings 2-post Brake Models	Replaces Dings 4-post Brake Models	Weight lbs.	Thermal Capacity HPS/Min	Dimensions in inches					List Price
						Inertia WK ² Lb-Ft ²	C	N Hub Location	X Hub Length	AC	
10	71010-SC6W	6-71010-93	6-71010-94	41	10	.047	6.91	1.50	1.00	1.13	\$
15	71015-SC6W	6-71015-93	6-71015-94	41	10	.047	6.91	1.50	1.00	1.13	\$
25	72025-SC6W	6-72025-93	6-72025-94	43	11	.047	6.91	2.00	1.50	1.13	\$
35	72035-SC6W	6-72035-93	6-72035-94	43	11	.075	6.91	2.00	1.50	1.13	\$
50	73050-SC6W	6-73050-93	6-73050-94	48	12	.075	7.47	2.50	2.00	1.69	\$
75	74075-SC6W	6-74075-93	6-74075-94	53	13	.103	8.03	3.00	2.50	2.25	\$
105	74105-SC6W	NEW	NEW	53	13	.131	8.03	3.00	2.50	2.25	\$

WASHDOWN NEMA 4X / IP56 Enclosure with hub seal STEARNS® REPLACEMENT

Cast Iron Construction

Stearns® Replacement	Torque lb-ft	Dings Model # Stearns® Replacement	Direct Drop-in replacement for Stearns® Model	Weight lbs.	Thermal Capacity HPS/Min	Inertia WK ² Lb-Ft ²	Dimensions in inches				List Price
							C	N Hub Location	X Hub Length	AC	
	10	71010-SC6T	1-087-012-B0	41	10	.045	6.91	1.13	1.00	1.13	\$
	15	71015-SC6T	1-087-022-B0	41	10	.045	6.91	1.13	1.00	1.13	\$
	25	71025-SC6T	1-087-032-B0	41	11	.045	6.91	1.13	1.00	1.13	\$
	35	72035-SC6T	1-087-042-B0	43	11	.074	6.91	1.13	1.00	1.13	\$
	50	72050-SC6T	1-087-052-B0	43	12	.077	6.91	1.63	1.50	1.13	\$
	75	73075-SC6T	1-087-062-B0	48	13	.105	7.47	1.63	1.50	1.69	\$
	105	74105-SC6T	1-087-082-B0	53	13	.136	8.03	2.13	2.00	2.25	\$

Stearns® is a Registered Trademark of Rexnord Corporation

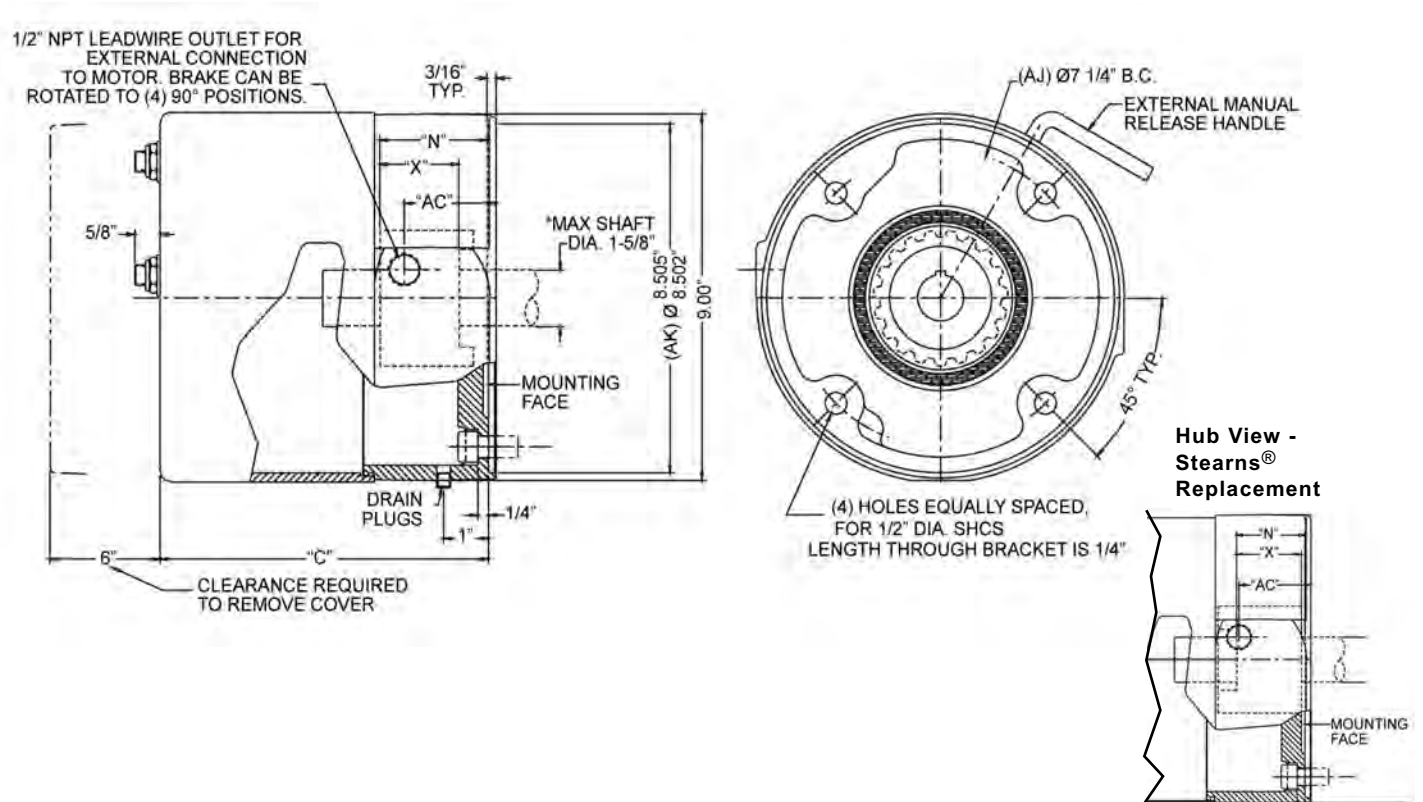

70 Series Double C Face

8700 Style

NEMA Frame Sizes 182TC through 256TC/UC

Torque Ratings: 10 to 105 lb-ft

Dripproof NEMA 2, CSA 2, IP43

NEW DESIGN

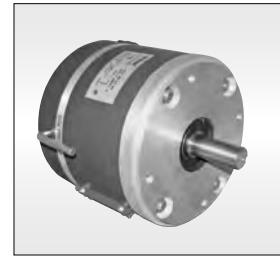

**No Disassembly
Required for Mounting**

Specifications:

Reaction Time: 20-25 milliseconds (release and set)
 AK: 8.5" Register
 AJ: 7.25" Bolt Circle
 Maximum RPM: 3600
 CSA File #LR13814
 Coil insulation: Class H Standard
 Construction: Cast Iron Bracket, Aluminum Housing
 Instruction & Parts Manual: BK4770

Design Features:

RoHS compliant
 Torque adjustable for specific applications
 Splined hub
 Spring set, electrically released
 Lead wires for conduit connections (internal connection available)
 Manual release, automatic reset
 All position brake available

[BACK TO TABLE
OF CONTENTS](#)

Brake Model Number Definition

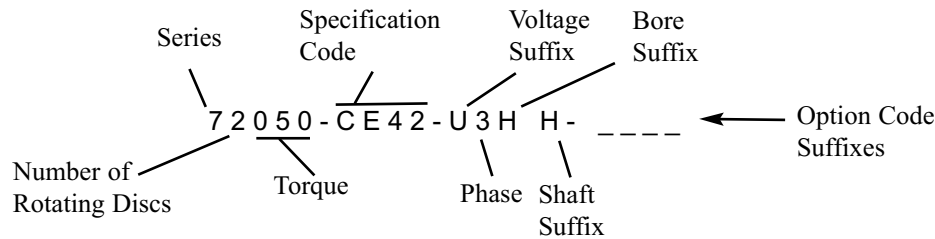

Standard Voltages (Single or three phase):

Suffix	Voltage
Y	110/220V, 50Hz
U	230/460V, 60 Hz or 190/380V, 50 Hz
5	208-230/460V, 60 Hz
R	115/230V, 60 Hz
1	115/208-230V, 60 Hz
T	220/440V, 60 Hz
P	575V, 60 Hz

Special voltages available.

Standard Hub Bore & Shaft Sizes:

Suffix	Bore Size	Shaft Size	Keyway
H	1 1/8"	1 1/8"	1/4" x 1/8"
K	1 3/8"	1 3/8"	5/16" x 5/32"
M	1 5/8"*	1 5/8"	3/8" x 3/16"

*For brakes below 75 lb-ft torque rating that require 1-5/8" bore size, contact factory.

Available Options:

	Suffix
Foot Mounting Bracket	F
Heavy-Duty Rotating Friction Disc	H
Marine/Maritime Duty with MIL-SPEC paint per TT-P-645 & MIL-DTL-15090	M
Marine/Maritime Duty	N
Tropical Protection	P
Internal Space Heater	R
Stainless Steel Stationary Disc	S
Vertical Mounting	
Vertical Over, or above motor	VO
Vertical Under, or below motor	VU
Micro-Switch Warning	XS

Refer to pages 51-56 for option descriptions & pricing.

NEMA 2 / IP43 Enclosure

Construction: Cast Iron Bracket, Aluminum Housing

[BACK TO TABLE OF CONTENTS](#)

Torque lb-ft	Dings Model #	Replaces Stearns® Model (NOTE1)	Thermal Capacity HPS/MIN	Inertia Wk ² lb-ft ²	Dimensions in inches				AHbore Max Motor Shaft Length			AHext Brake Shaft Extension Length			List Price
					C	X	AC	N	1.125	1.375	1.625	1.125	1.375	1.625	
									Dia	Dia	Dia	Dia	Dia	Dia	
10	71010-CE42	1-087-711	10	0.055	7.53	1.00	1.13	0.13	2.63	3.13	N/A	2.63	3.13	3.75	\$
15	71015-CE42	1-087-721	10	0.055	7.53	1.00	0.13	\$							
25	72025-CE42	1-087-731	11	0.076	7.53	1.00	0.13	\$							
35	72035-CE42	1-087-741	11	0.076	7.53	1.00	0.13	\$							
50	72050-CE42	1-087-751	11	0.076	7.53	1.00	0.13	3.75	3.75	3.75	2.63	3.13	3.75	\$	
75	74075-CE41	1-087-761	13	0.145	8.66	2.38	0.50							\$	
105	74105-CE41	1-087-781	13	0.145	8.66	2.38	0.50							\$	

NOTE 1: Hub length and location may differ.

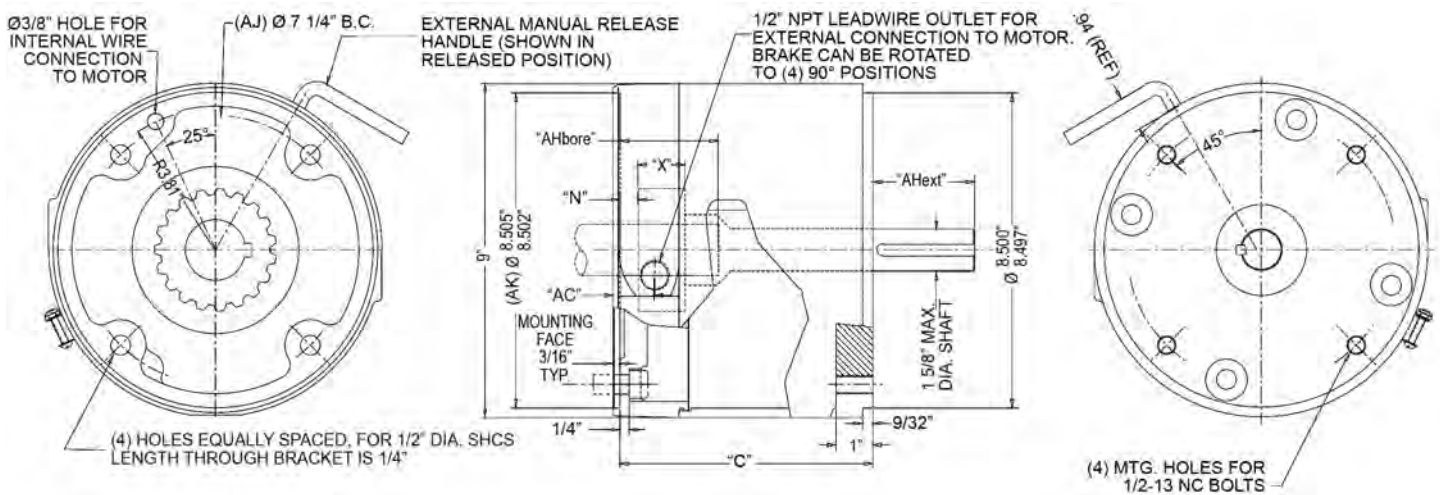

Stearns® is a Registered Trademark of Rexnord Corporation

70 Series Double C Face

8700 Style

NEMA Frame Sizes 182TC through 256TC/UC
Torque Ratings: 10 to 105 lb-ft

NEMA 4, CSA 4, IP56



**No Disassembly
Required for Mounting**

[BACK TO TABLE
OF CONTENTS](#)

Specifications:

Reaction Time: 20-25 milliseconds (release and set)
AK: 8.5" Register
AJ: 7.25" Bolt Circle
Maximum RPM: 3600
CSA File #LR13814
Coil insulation: Class H Standard
Construction: Cast Iron Bracket, Aluminum Housing
Instruction & Parts Manual: BK4770

Design Features:

RoHS compliant
Torque adjustable for specific applications
Splined hub
Spring set, electrically released
Lead wires for conduit connections
(internal connection available)
Manual release, automatic reset
All position brake available

Brake Model Number Definition

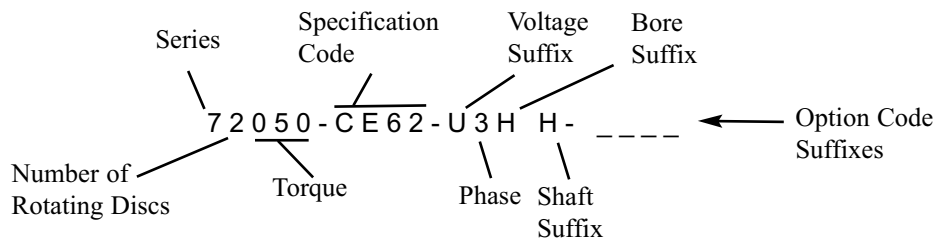

Standard Voltages (Single or three phase):

Suffix	Voltage
Y	110/220V, 50Hz
U	230/460V, 60 Hz or 190/380V, 50 Hz
5	208-230/460V, 60 Hz
R	115/230V, 60 Hz
1	115/208-230V, 60 Hz
T	220/440V, 60 Hz
P	575V, 60 Hz

Special voltages available.

Standard Hub Bore & Shaft Sizes:

Suffix	Bore Size	Shaft Size	Keyway
H	1 1/8"	1 1/8"	1/4" x 1/8"
K	1 3/8"	1 3/8"	5/16" x 5/32"
M	1 5/8"*	1 5/8"	3/8" x 3/16"

*For brakes below 75 lb-ft torque rating that require 1-5/8" bore size, contact factory.

Available Options:

	Suffix
Foot Mounting Bracket	F
Heavy-Duty Rotating Friction Disc	H
Marine/Maritime Duty with MIL-SPEC paint per TT-P-645 & MIL-DTL-15090	M
Marine/Maritime Duty	N
Tropical Protection	P
Internal Space Heater	R
Stainless Steel Stationary Disc	S
Vertical Mounting	
Vertical Over, or above motor	VO
Vertical Under, or below motor	VU
Micro-Switch Warning	XS

Refer to pages 51-56 for option descriptions & pricing.

Torque lb-ft	Dings Model #	Replaces Stearns® Model (NOTE1)	Thermal Capacity HPS/MIN	Inertia Wk ² lb-ft ²	Dimensions in inches				AHbore Max Motor Shaft Length			AHext Brake Shaft Extension Length			List Price
					C	X	AC	N	1.125	1.375	1.625	1.125	1.375	1.625	
									Dia	Dia	Dia	Dia	Dia	Dia	
10	71010-CE62	1-087-712	10	0.055	7.53	1.00	1.13	0.13	2.63	3.13	N/A	2.63	3.13	3.75	\$
15	71015-CE62	1-087-722	10	0.055	7.53	1.00	1.13	0.13							\$
25	72025-CE62	1-087-732	11	0.076	7.53	1.00	1.13	0.13							\$
35	72035-CE62	1-087-742	11	0.076	7.53	1.00	1.13	0.13							\$
50	72050-CE62	1-087-752	11	0.076	7.53	1.00	1.13	0.13							\$
75	74075-CE61	1-087-762	13	0.145	8.66	2.38	2.25	0.50	3.75	3.75	3.75	\$			
105	74105-CE61	1-087-782	13	0.145	8.66	2.38	2.25	0.50				\$			

NOTE 1: Hub length and location may differ.

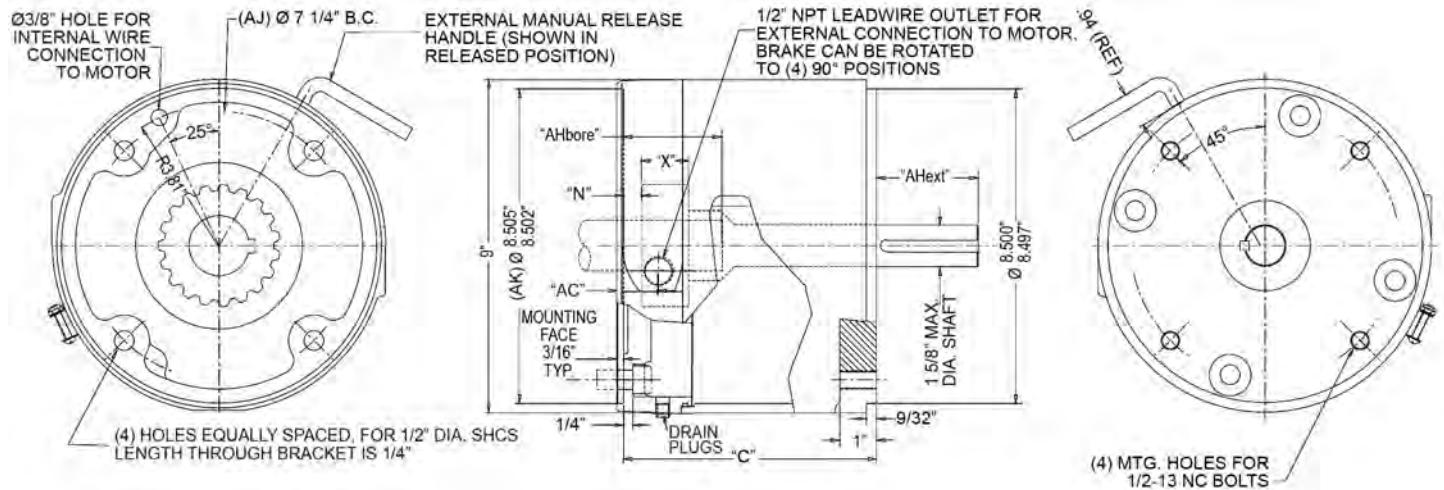

Stearns® is a Registered Trademark of Rexnord Corporation

70 Series Double C Face

8700 Style

NEMA Frame Sizes 182TC through 256TC/UC
Torque Ratings: 10 to 105 lb-ft

NEMA 4X, CSA 4, IP56

NEW DESIGN



**No Disassembly
Required for Mounting**

[BACK TO TABLE
OF CONTENTS](#)

Specifications:

Reaction Time: 20-25 milliseconds (release and set)
AK: 8.5" Register
AJ: 7.25" Bolt Circle
Maximum RPM: 3600
CSA File #LR13814
Coil insulation: Class H Standard
Construction: Cast Iron Bracket, Aluminum Housing
BISSC Certified Authorization #695
Exterior paint: FDA approved white epoxy paint
Plated internal parts - RoHS compliant
Instruction & Parts Manual: BK4771

Design Features:

RoHS compliant
Torque adjustable for specific applications
Splined hub
Spring set, electrically released
Lead wires for conduit connections
(internal connection available)
Manual release, automatic reset
All position brake available

Brake Model Number Definition

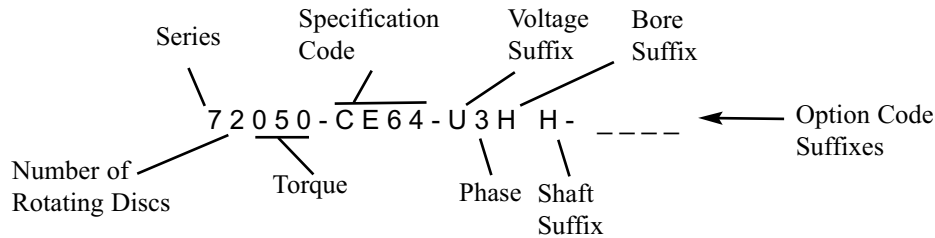

Standard Voltages (Single or three phase):

Suffix	Voltage
Y	110/220V, 50Hz
U	230/460V, 60 Hz or 190/380V, 50 Hz
5	208-230/460V, 60 Hz
R	115/230V, 60 Hz
1	115/208-230V, 60 Hz
T	220/440V, 60 Hz
P	575V, 60 Hz

Special voltages available.

Standard Hub Bore & Shaft Sizes:

Suffix	Bore Size	Shaft Size	Keyway
H	1 1/8"	1 1/8"	1/4" x 1/8"
K	1 3/8"	1 3/8"	5/16" x 5/32"
M	1 5/8"*	1 5/8"	3/8" x 3/16"

*For brakes below 75 lb-ft torque rating that require 1-5/8" bore size, contact factory.

Available Options:

	Suffix
Foot Mounting Bracket	F
Heavy-Duty Rotating Friction Disc	H
Marine/Maritime Duty with MIL-SPEC paint per TT-P-645 & MIL-DTL-15090	M
Marine/Maritime Duty	N
Tropical Protection	P
Internal Space Heater	R
Stainless Steel Stationary Disc	S
Vertical Mounting	
Vertical Over, or above motor	VO
Vertical Under, or below motor	VU
Micro-Switch Warning	XS

Refer to pages 51-56 for option descriptions & pricing.

NEMA 4X / IP56 Enclosure

Construction: Cast Iron Bracket, Aluminum Housing

[BACK TO TABLE OF CONTENTS](#)

Torque lb-ft	Dings Model #	Replaces Stearns® Model (NOTE1)	Thermal Capacity HPS/MIN	Inertia Wk ² lb-ft ²	Dimensions in inches				AHbore Max Motor Shaft Length			AHext Brake Shaft Extension Length			List Price
					C	X	AC	N	1.125	1.375	1.625	1.125	1.375	1.625	
									Dia	Dia	Dia	Dia	Dia	Dia	
10	71010-CE64	1-087-712	10	0.055	7.53	1.00	1.13	0.13	2.63	3.13	N/A	2.63	3.13	3.75	\$
15	71015-CE64	1-087-722	10	0.055	7.53	1.00	1.13	0.13							\$
25	72025-CE64	1-087-732	11	0.076	7.53	1.00	1.13	0.13							\$
35	72035-CE64	1-087-742	11	0.076	7.53	1.00	1.13	0.13							\$
50	72050-CE64	1-087-752	11	0.076	7.53	1.00	1.13	0.13	3.75	3.75	3.75			\$	
75	74075-CE63	1-087-762	13	0.145	8.66	2.38	2.25	0.50						\$	
105	74105-CE63	1-087-782	13	0.145	8.66	2.38	2.25	0.50						\$	

NOTE 1: Hub length and location may differ.

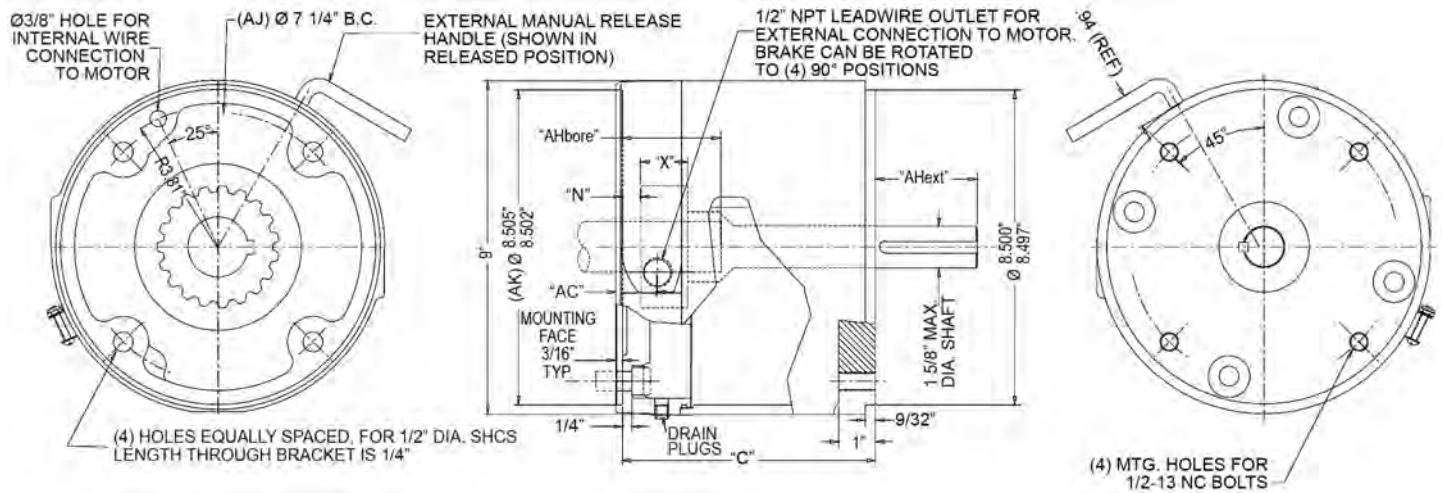

Stearns® is a Registered Trademark of Rexnord Corporation

70 Series Double Shafted with Foot Mount

Torque Ratings: 10 to 105 lb-ft

[BACK TO TABLE
OF CONTENTS](#)

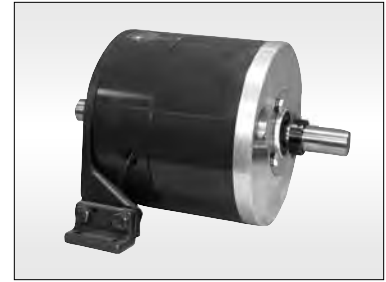

Specifications:

Reaction Time: 20-25 milliseconds (release and set)
Maximum RPM: 3600
Coil insulation: Class H Standard

Enclosure Types:

Dripproof Enclosure, NEMA 2, CSA 2, IP43, Model 70000-DE41
NEMA 4, CSA 4, IP56, Model 70000-DE61
Cast iron bracket and aluminum housing
Exterior paint: Red primer

Design Features:

RoHS compliant
Torque adjustable for specific applications
Splined hub
Spring set, electrically released
Lead wires for conduit connections
(internal connection available)
Manual release, automatic reset
All position brake available

Brake Model Number Definition

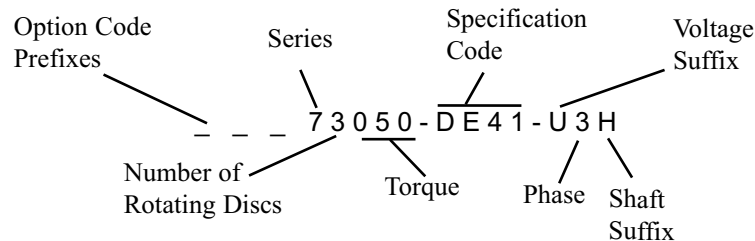

Standard Voltages

(single or three phase):

Suffix Voltage

Y	110/220V, 50Hz
U	230/460V, 60 Hz or 190/380V, 50 Hz
5	208-230/460V, 60 Hz
R	115/230V, 60 Hz
1	115/208-230V, 60 Hz
T	220/440V, 60 Hz
P	575V, 60 Hz

Special voltages available.

Standard Shaft Sizes:

Suffix	Shaft Size	Keyway
H	1 1/8"	1/4" x 1/8"
K	1 3/8"	5/16" x 5/32"
M	1 5/8"	3/8" x 3/16"

Special shaft sizes available.

Available Options:

	Prefix
Heavy-Duty Rotating Friction Disc	H
Marine/Maritime Duty with MIL-SPEC paint per TT-P-645 & MIL-DTL-15090	M
Marine/Maritime Duty	N
Tropical Protection	P
Internal Space Heater	R
Stainless Steel Stationary Disc	S
Vertical Mounting	
Vertical Over, or above motor	VO
Vertical Under, or below motor	VU
Micro-Switch Warning	XS

Refer to pages 51-56 for option descriptions & pricing.

NEMA 2 Specifications

Torque lb-ft	Model #	Replacement for Stearns® Model (NOTE1)	Enclosure	Wt. Lbs.	Thermal Capacity HPS/MIN	Inertia Wk ² lb-ft ²	Dimensions in inches				List Price
							A	C 1-1/8" shaft	C 1-3/8" shaft	AC	
10	71010-DE41	1-087-211-00	NEMA 2	45	10	0.069	NEW BRAKE DESIGN- CONTACT FACTORY FOR OUTLINE DRAWING				\$
15	71015-DE41	1-087-221-00	NEMA 2	45	10	0.069					\$
25	72025-DE41	1-087-231-00	NEMA 2	49	11	0.110					\$
35	72035-DE41	1-087-241-00	NEMA 2	49	11	0.110					\$
50	73050-DE41	1-087-251-00	NEMA 2	53	12	0.150					\$
75	74075-DE41	1-087-261-00	NEMA 2	57	13	0.190					\$
105	74105-DE41	1-087-281-00	NEMA 2	57	13	0.190					\$

NEMA 4 Specifications

Torque lb-ft	Model #	Replacement for Stearns® Model (NOTE1)	Enclosure	Wt. Lbs.	Thermal Capacity HPS/MIN	Inertia Wk ² lb-ft ²	Dimensions in inches				List Price
							A	C 1-1/8" shaft	C 1-3/8" shaft	AC	
10	71010-DE61	1-087-212-00	NEMA 4	45	10	0.069	NEW BRAKE DESIGN- CONTACT FACTORY FOR OUTLINE DRAWING				\$
15	71015-DE61	1-087-222-00	NEMA 4	45	10	0.069					\$
25	72025-DE61	1-087-232-00	NEMA 4	49	11	0.110					\$
35	72035-DE61	1-087-242-00	NEMA 4	49	11	0.110					\$
50	73050-DE61	1-087-252-00	NEMA 4	53	12	0.150					\$
75	74075-DE61	1-087-262-00	NEMA 4	57	13	0.190					\$
105	74105-DE61	1-087-282-00	NEMA 4	57	13	0.190					\$

NOTE 1: Not a direct drop-in for Stearns models; review outline drawing and dimensions.

Stearns® is a Registered Trademark of Rexnord Corporation

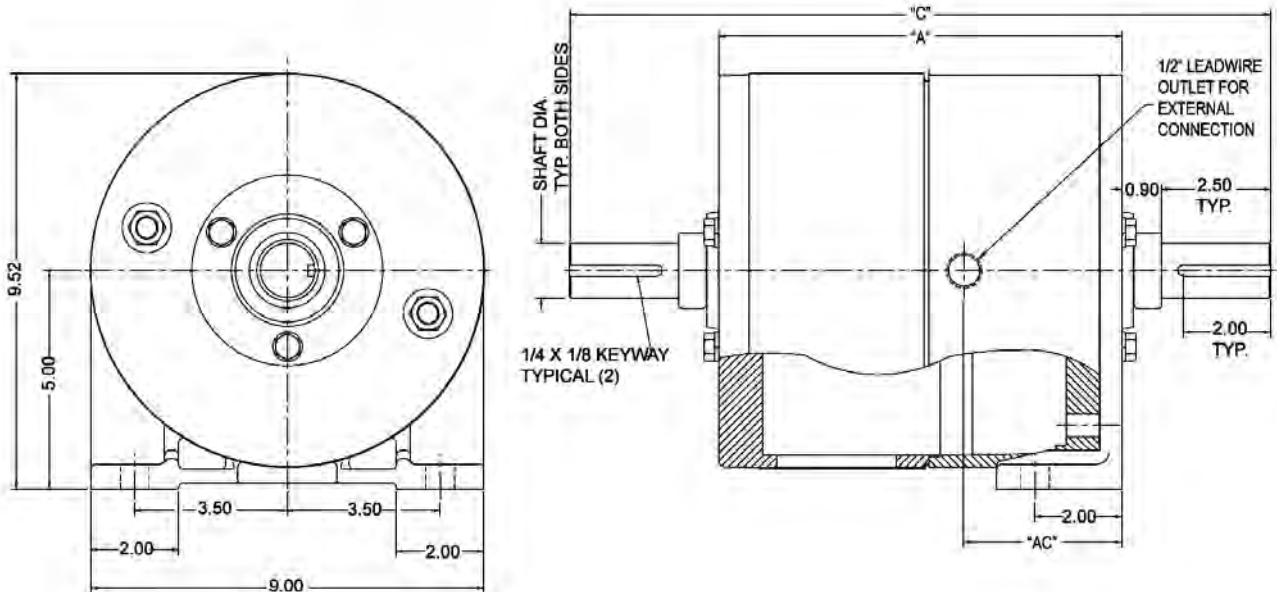

80 Series End Mount

[BACK TO TABLE OF CONTENTS](#)



No Disassembly Required for Mounting

NEMA Frame Sizes 284TC/UC, 286TC/UC

Torque Ratings: 25 to 175 lb-ft

Dripproof NEMA 2, CSA 2, IP41

80 Series Specifications:

Reaction Time: 20-25 milliseconds (release and set)

AK: 10.5" Register

AJ: 9.00" Bolt Circle

Maximum RPM: 2400

CSA File #LR13814

Coil insulation: Class H

NEMA 2 Specifications:

External paint: Red primer

Lead wires: Internal or conduit connections

Nameplate: Stamped stainless steel

HEAVY DUTY 4 Post Design

Instruction & Parts Manual:

NEMA 2 cast iron/steel: BK4804

NEMA 2 cast iron/aluminum: BK4604

Design Features:

RoHS compliant

No disassembly required for mounting

Direct acting design with no linkages to break

One moving part for longer life

Torque adjustable for specific applications

Splined hub

Spring set, electrically released

Manual release, automatic reset

All position brake available

External manual release available

Refer to brake options on pages 51-56

Brake Model Number Definition

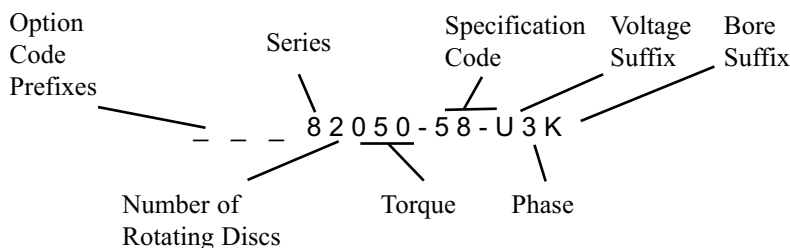

Standard Voltages (single and three phase):

Suffix	Voltage
Y	110/220V, 50Hz
U	230/460V, 60 Hz or 190/380V, 50 Hz
R	115/230V, 60 Hz
T	220/440V, 60 Hz
P	575V, 60 Hz

Special voltages available.

Standard Hub Bore Sizes:

Suffix	Size	Keyway Width
F	7/8"	3/16" x 3/32"
H	1 1/8"	1/4" x 1/8"
J	1 1/4"	1/4" x 1/8"
K	1 3/8"	5/16" x 5/32"
M	1 5/8"	3/8" x 3/16"
N	1 7/8"	1/2" x 1/4"

Special bore sizes available.

Available Options:

Option	Prefix
Adapter to Larger Frame Size(s)	A
Reverse Adapter	AB
Ductile Iron Stationary Disc	E
Foot Mounting Bracket	F
Harsh Environment Protection	G
Heavy-Duty Rotating Friction Disc with Hardened Steel Hub	H
High Tensile Studs	J
Marine/Maritime Duty with MIL-SPEC paint per TT-P-645 & MIL-DTL-15090	M
Marine/Maritime Duty	N
Tropical Protection	P
Internal Space Heater	R
Stainless Steel Stationary Disc	S
Through Shaft	T
Vertical Mounting	
Vertical Over, or above motor	VO
Vertical Under, or below motor	VU
Micro-Switch Warning	XS

Refer to pages 51-56 for option descriptions & pricing.

NEMA 2 / IP41 Enclosure, Cast Iron/Steel

Torque lb-ft	Model #	Construction	Wt. Lbs.	Thermal Capacity HPS/Min	Inertia WK ² Lb-Ft ²	Dimensions in inches				List Price
						C	N	X	AC	
25	81025-58	Cast Iron/Steel	57	15	0.084	5.95	1.75	1.00	1.48	\$
35	81035-58	Cast Iron/Steel	57	15	0.084	5.95	1.75	1.00	1.48	\$
50	82050-58	Cast Iron/Steel	65	17	0.158	6.58	2.25	1.50	2.10	\$
70	82070-58	Cast Iron/Steel	65	17	0.158	6.58	2.25	1.50	2.10	\$
75	83075-58	Cast Iron/Steel	70	19	0.233	7.20	2.75	2.00	2.73	\$
105	83105-58	Cast Iron/Steel	70	19	0.233	7.83	2.75	2.00	3.35	\$
125	84125-58	Cast Iron/Steel	75	21	0.307	8.12	3.25	2.50	3.60	\$
175	85175-58	Cast Iron/Steel	81	21	0.384	8.75	3.87	3.12	4.23	\$

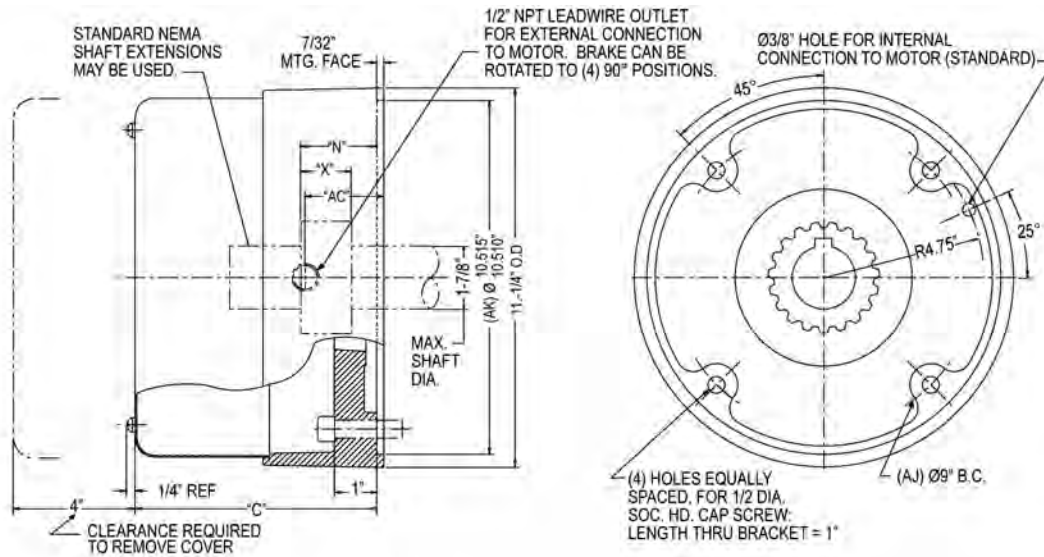

NEMA 2 / IP41 Enclosure, Cast Iron/Aluminum

Torque lb-ft	Model No.	Wt. Lbs.	Thermal Capacity HPS/Min	Inertia WK ² lb-ft ²	Dimensions in inches				List Price
					C	N	X	AC	
25	81025-28	60	15	0.084	6.31	1.75	1.00	1.73	\$
35	81035-28	60	15	0.084	6.31	1.75	1.00	1.73	\$
50	82050-28	68	17	0.158	6.94	2.25	1.50	2.35	\$
70	82070-28	68	17	0.158	6.94	2.25	1.50	2.35	\$
75	83075-28	73	19	0.233	7.56	2.75	2.00	2.98	\$
105	83105-28	74	19	0.233	7.56	2.75	2.00	2.98	\$
125	84125-28	79	21	0.307	8.12	3.25	2.50	3.60	\$
175	85175-28	85	21	0.384	8.81	3.87	3.12	4.23	\$

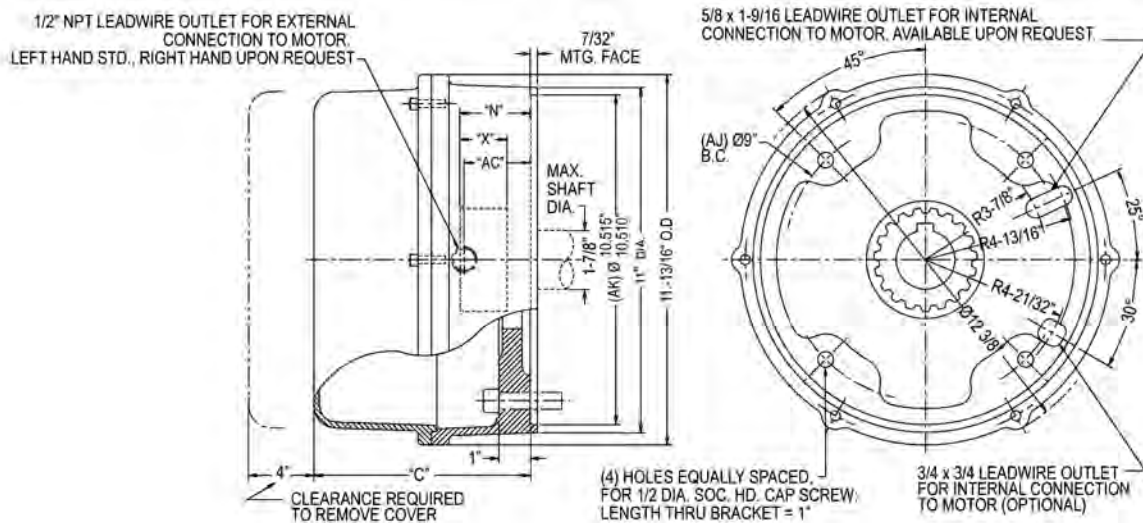

80 Series End Mount

[BACK TO TABLE OF CONTENTS](#)

NEMA Frame Sizes 284TC/UC, 286TC/UC

Torque Ratings: 25 to 175 lb-ft

NEMA 4, CSA 4, IP56 without hub seal for Non-TEFC applications



**No Disassembly
Required for Mounting**

80 Series Specifications:

Reaction Time: 20-25 milliseconds
(release and set)

AK: 10.5" Register
AJ: 9.00" Bolt Circle
Maximum RPM: 2400
CSA File #LR13814
Coil insulation: Class H

NEMA 4 Non-TEFC Specifications:

Without hub seal for non-TEFC applications
External paint: Red primer
Lead wires: Internal or conduit connections
Nameplate: Stamped stainless steel
HEAVY DUTY 4 Post Design
Instruction & Parts Manual: BK4814

Design Features:

RoHS compliant
No disassembly required for mounting
Direct acting design with no linkages to break
One moving part for longer life
Torque adjustable for specific applications
Splined hub
Spring set, electrically released
Manual release, automatic reset
All position brake available
External manual release available
Refer to brake options on pages 51-56

Brake Model Number Definition

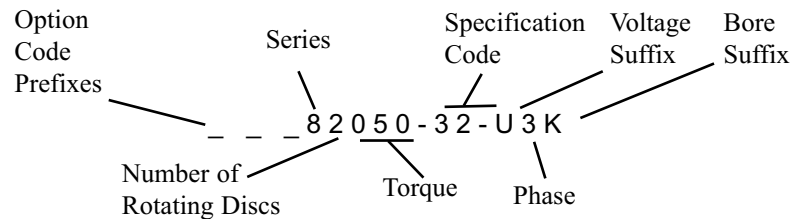

Standard Voltages (single and three phase):

Suffix	Voltage
Y	110/220V, 50Hz
U	230/460V, 60 Hz or 190/380V, 50 Hz
R	115/230V, 60 Hz
T	220/440V, 60 Hz
P	575V, 60 Hz

Special voltages available.

Standard Hub Bore Sizes:

Suffix	Size	Keyway Width
F	7/8"	3/16" x 3/32"
H	1 1/8"	1/4" x 1/8"
J	1 1/4"	1/4" x 1/8"
K	1 3/8"	5/16" x 5/32"
M	1 5/8"	3/8" x 3/16"
N	1 7/8"	1/2" x 1/4"

Special bore sizes available.

Available Options:

Option	Prefix
Adapter to Larger Frame Size(s)	A
Reverse Adapter	AB
Ductile Iron Stationary Disc	E
Foot Mounting Bracket	F
Harsh Environment Protection	G
Heavy-Duty Rotating Friction Disc with Hardened Steel Hub	H
High Tensile Studs	J
Marine/Maritime Duty with MIL-SPEC paint per TT-P-645 & MIL-DTL-15090	M
Marine/Maritime Duty	N
Tropical Protection	P
Internal Space Heater	R
Stainless Steel Stationary Disc	S
Through Shaft	T
Vertical Mounting	
Vertical Over, or above motor	VO
Vertical Under, or below motor	VU
Micro-Switch Warning	XS

Refer to pages 51-56 for option descriptions & pricing.

NEMA 4 / IP56 Enclosure without hub seal for non-TEFC applications

[BACK TO TABLE OF CONTENTS](#)

Torque lb-ft	Model No.	Construction	Wt. Lbs.	Thermal Capacity HPS/Min	Inertia WK ² lb-ft ²	Dimensions in inches				List Price
						C	N	X	AC	
25	81025-32	Cast Iron	57	15	0.084	6.25	1.75	1.00	1.73	\$
35	81035-32	Cast Iron	57	15	0.084	6.25	1.75	1.00	1.73	\$
50	82050-32	Cast Iron	65	17	0.158	6.87	2.25	1.50	2.35	\$
70	82070-32	Cast Iron	65	17	0.158	6.87	2.25	1.50	2.35	\$
75	83075-32	Cast Iron	70	19	0.233	7.50	2.75	2.00	2.98	\$
105	83105-32	Cast Iron	70	19	0.233	7.50	2.75	2.00	2.98	\$
125	84125-32	Cast Iron	75	21	0.307	8.12	3.25	2.50	3.60	\$
175	85175-32	Cast Iron	81	21	0.384	8.75	3.87	3.12	4.23	\$

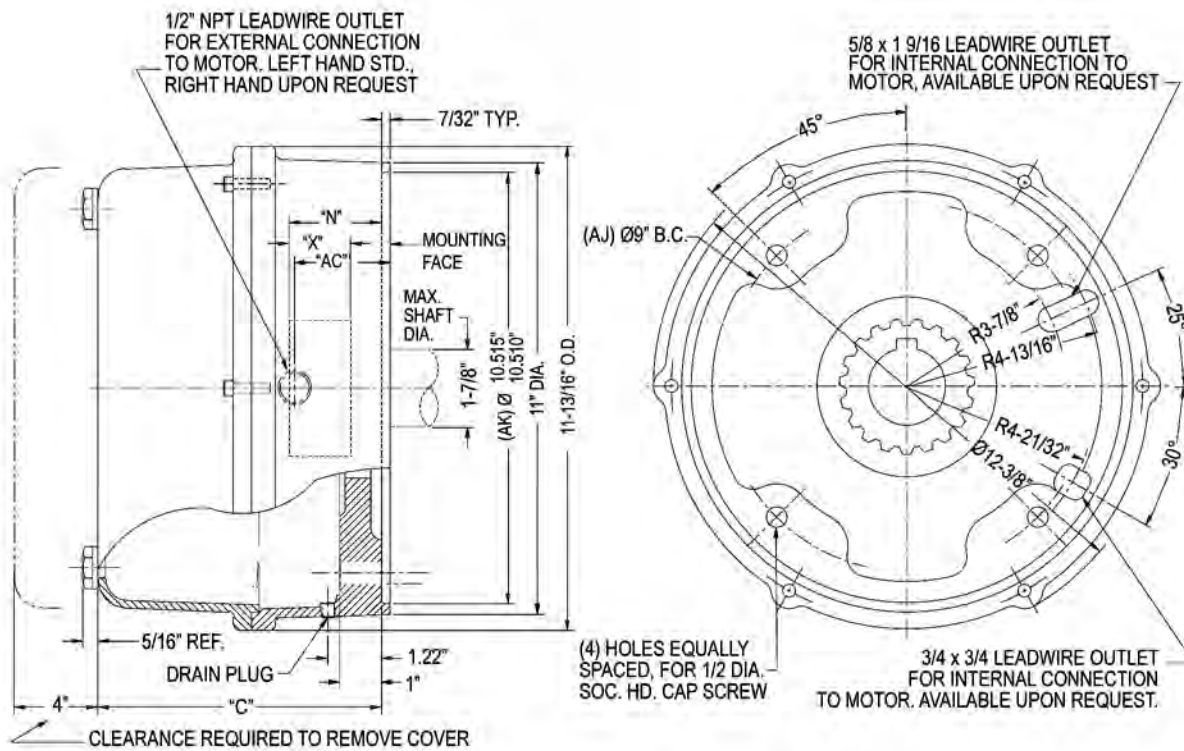

80 Series End Mount

[BACK TO TABLE OF CONTENTS](#)

NEMA Frame Sizes 284TC/UC, 286TC/UC

Torque Ratings: 25 to 175 lb-ft

NEMA 4, CSA 4, IP56* with hub seal for TEFC applications



**No Disassembly
Required for Mounting**

*To obtain full IP56 protection, the customer shaft, hub bore, key and keyway's mating surface(s) must be sealed to meet IP56. Considerations should be reviewed to appropriately seal mounting hardware as well. Contact factory for details and/or assistance.

80 Series Specifications:

Reaction Time: 20-25 milliseconds
(release and set)
AK: 10.5" Register
AJ: 9.00" Bolt Circle
Maximum RPM: 2400
CSA File #LR13814
Coil insulation: Class H

Design Features:

RoHS compliant
No disassembly required for mounting
Direct acting design with no linkages to break
One moving part for longer life
Torque adjustable for specific applications
Splined hub
Spring set, electrically released
Manual release, automatic reset
All position brake available
External manual release available
Refer to brake options on pages 51-56

NEMA 4 TEFC Specifications:

External paint: Red primer
Lead wires: Conduit connections
Nameplate: Stamped stainless steel
HEAVY DUTY 4 Post Design
Instruction & Parts Manual: BK4814

Brake Model Number Definition

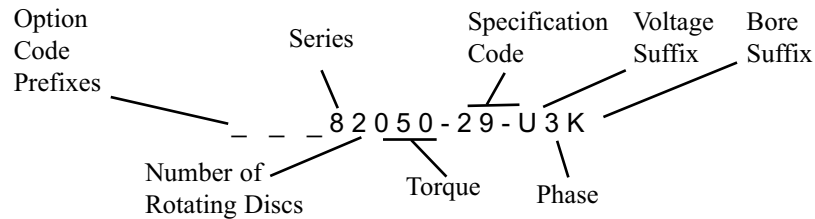

Standard Voltages (single and three phase):

Suffix	Voltage
Y	110/220V, 50Hz
U	230/460V, 60 Hz or 190/380V, 50 Hz
R	115/230V, 60 Hz
T	220/440V, 60 Hz
P	575V, 60 Hz

Special voltages available.

Standard Hub Bore Sizes:

Suffix	Size	Keyway Width
F	7/8"	3/16" x 3/32"
H	1 1/8"	1/4" x 1/8"
J	1 1/4"	1/4" x 1/8"
K	1 3/8"	5/16" x 5/32"
M	1 5/8"	3/8" x 3/16"
N	1 7/8"	1/2" x 1/4"

Special bore sizes available.

Available Options:

Option	Prefix
Adapter to Larger Frame Size(s)	A
Reverse Adapter	AB
Ductile Iron Stationary Disc	E
Foot Mounting Bracket	F
Harsh Environment Protection	G
Heavy-Duty Rotating Friction Disc with Hardened Steel Hub	H
High Tensile Studs	J
Marine/Maritime Duty with MIL-SPEC paint per TT-P-645 & MIL-DTL-15090	M
Marine/Maritime Duty	N
Tropical Protection	P
Internal Space Heater	R
Stainless Steel Stationary Disc	S
Through Shaft	T
Vertical Mounting	
Vertical Over, or above motor	VO
Vertical Under, or below motor	VU
Micro-Switch Warning	XS

Refer to pages 51-56 for option descriptions & pricing.

NEMA 4 / IP56 Enclosure with hub seal

BACK TO TABLE
OF CONTENTS

Torque lb-ft	Model No.	Construction	Wt. Lbs.	Thermal Capacity HPS/Min	Inertia WK ² lb-ft ²	Dimensions in inches					List Price
						C	N	X	Xb	AC	
25	81025-29	Cast Iron	57	15	0.084	6.25	1.75	1.31	1.00	1.73	\$
35	81035-29	Cast Iron	57	15	0.084	6.25	1.75	1.31	1.00	1.73	\$
50	82050-29	Cast Iron	65	17	0.158	6.87	2.25	1.81	1.50	2.35	\$
70	82070-29	Cast Iron	65	17	0.158	6.87	2.25	1.81	1.50	2.35	\$
75	83075-29	Cast Iron	70	19	0.233	7.50	2.75	2.31	2.00	2.98	\$
105	83105-29	Cast Iron	70	19	0.233	7.50	2.75	2.31	2.00	2.98	\$
125	84125-29	Cast Iron	75	21	0.307	8.12	3.25	2.81	2.50	3.60	\$
175	85175-29	Cast Iron	81	21	0.384	8.75	3.87	3.44	3.13	4.23	\$

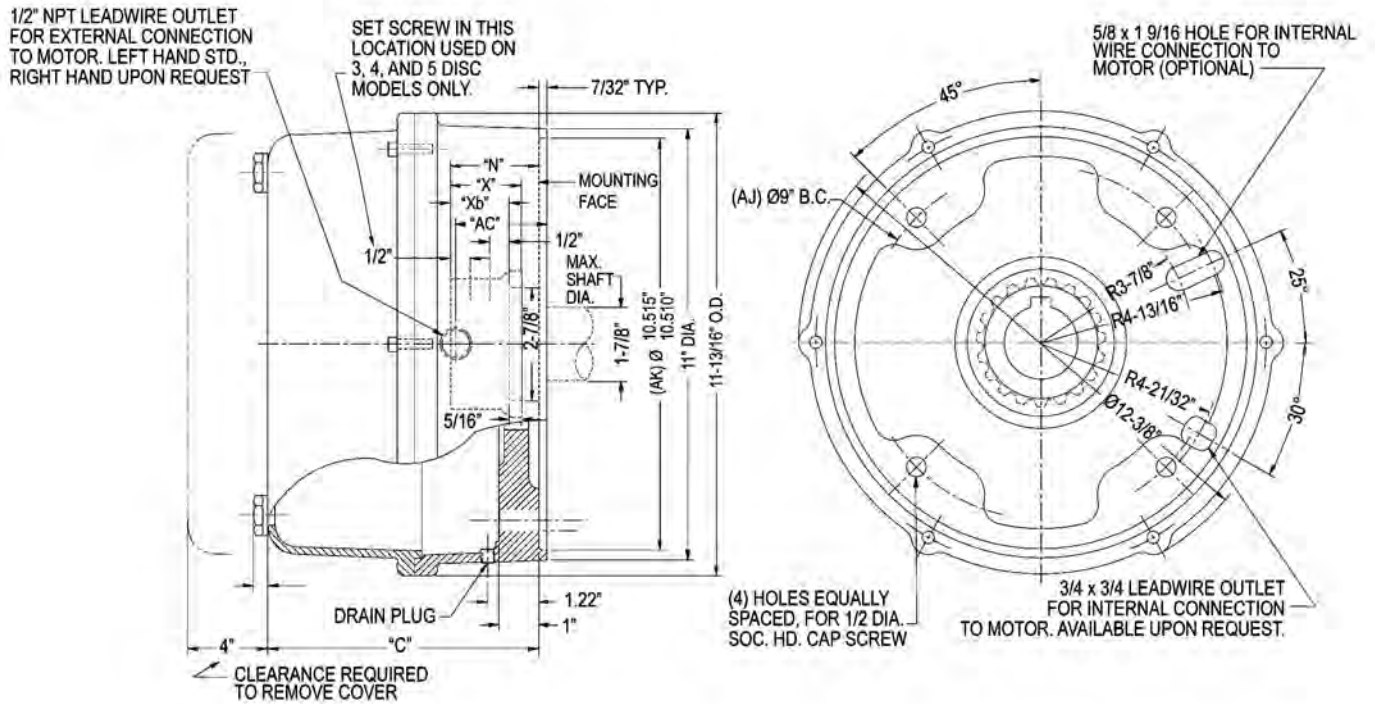

90 Series End Mount

[BACK TO TABLE OF CONTENTS](#)

NEMA Frame Sizes 324TC/UC/TSC/USC
through 405TC/UC/TSC/USC
Torque Ratings: 125 to 450 lb-ft

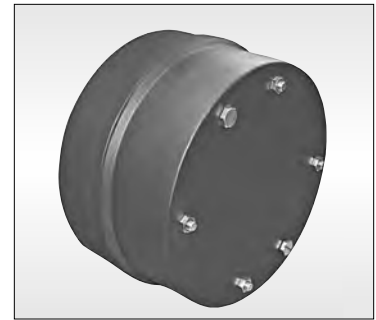

**No Disassembly
Required for Mounting**

Specifications:

- Reaction Time: 20-25 milliseconds (release and set)
- AK: 12.5" Register
- AJ: 11" Bolt Circle
- Thermal Capacity: 20 HPS/MIN
- Maximum RPM: 1800
- Coil insulation: Class H Standard
- CSA File #LR13814 (IEEE nameplate standard)
- External paint: Red primer
- Instructions & parts manual:
 - NEMA 2 = BK4699
 - NEMA 4 = BK4696

Design Features:

- RoHS compliant
- Torque adjustable for specific applications
- Splined hub
- Spring set, electrically released
- Lead wires for conduit connections
- Manual release, automatic reset
- High tensile studs standard

Enclosure Types:

Dripproof Enclosure 90000-50

- NEMA 2, CSA 2, IP41
- Cast iron cover and bracket

Waterproof/Dusttight Enclosure 90000-51

- NEMA 4, CSA 4, IP56*
- Cast iron cover and bracket
- Also available without hub seal for non-TEFC applications, model 90000-52

*To obtain full IP56 protection, the customer shaft, hub bore, key and keyway's mating surface(s) must be sealed to meet IP56. Considerations should be reviewed to appropriately seal mounting hardware as well. Contact factory for details and/or assistance.

Brake Model Number Definition

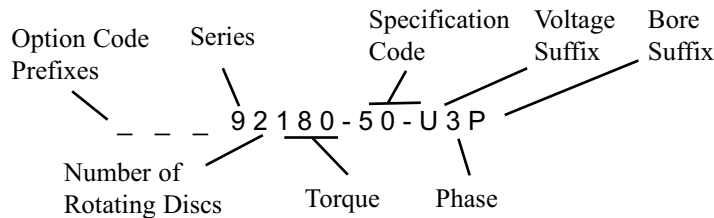

Standard Voltages (three phase only):	
Suffix	Voltage
Y	110/220V, 50Hz
U	230/460V, 60 Hz or 190/380V, 50 Hz
R	115/230V, 60 Hz
T	220/440V, 60 Hz
P	575V, 60 Hz

Special voltages available.

Standard Hub Bore Sizes:		
Suffix	Size	Keyway
N	1 7/8"	1/2" x 1/4"
O	2 1/8"	1/2" x 1/4"
P	2 3/8"	5/8" x 5/16"
Q	2 7/8"	3/4" x 3/8"

Special bore sizes available.

Available Options:	Prefix
Adapter to Larger Frame Size(s)	A
Reverse Adapter	AB
Foot Mounting Bracket	F
Heavy-Duty Rotating Friction Disc with Hardened Steel Hub	H
External Breather	K
Marine/Maritime Duty with MIL-SPEC paint per TT-P-645 & MIL-DTL-15090	M
Marine/Maritime Duty	N
Tropical Protection	P
Internal Space Heater	R
Stainless Steel Stationary Disc	S
Through Shaft	T
Vertical Mounting	
Vertical Over, or above motor	VO
Vertical Under, or below motor	VU
Micro-Switch Warning	XS

Refer to pages 51-56 for option descriptions & pricing.

Torque lb-ft	Model #	Replacement for Stearns® Model	Enclosure	Construction	Wt. Lbs.	Inertia Wk ² Lb-Ft ²	Dimensions in inches				List Price
							C	N	X	AC	
125	92125-50	1-082-011-02	NEMA 2	Cast Iron	126	1.0	7.88	2.31	2.31	2.19	\$
	92125-51	1-082-012-02	NEMA 4	Cast Iron	128	1.0	7.88	2.31	2.31	2.19	\$
180	92180-50	1-082-021-02	NEMA 2	Cast Iron	126	1.0	7.88	2.31	2.31	2.19	\$
	92180-51	1-082-022-02	NEMA 4	Cast Iron	128	1.0	7.88	2.31	2.31	2.19	\$
230	93230-50	1-082-031-02	NEMA 2	Cast Iron	139	1.3	8.25	2.94	2.94	2.19	\$
	93230-51	1-082-032-02	NEMA 4	Cast Iron	139	1.3	8.25	2.94	2.94	2.19	\$
270	93270-50	—	NEMA 2	Cast Iron	139	1.3	8.25	2.94	2.94	2.19	\$
	93270-51	—	NEMA 4	Cast Iron	139	1.3	8.25	2.94	2.94	2.19	\$
330	94330-50*	1-082-041-02*	NEMA 2	Cast Iron	147	1.6	8.88	3.56	3.56	3.44	\$
	94330-51*	1-082-042-02*	NEMA 4	Cast Iron	149	1.6	8.88	3.56	3.56	3.44	\$
360	94360-50	—	NEMA 2	Cast Iron	147	1.6	8.88	3.56	3.56	3.44	\$
	94360-51	—	NEMA 4	Cast Iron	149	1.6	8.88	3.56	3.56	3.44	\$
450	95450-50*	1-082-051-02*	NEMA 2	Cast Iron	157	1.9	9.28	4.19	4.19	4.06	\$
	95450-51*	1-082-052-02*	NEMA 4	Cast Iron	159	1.9	9.28	4.19	4.19	4.06	\$

*Specify requirement for Stearns replacement at time of order Stearns® is a registered trademark of Rexnord Corporation.

OUTLINE DRAWING, NEMA 2 ENCLOSURE

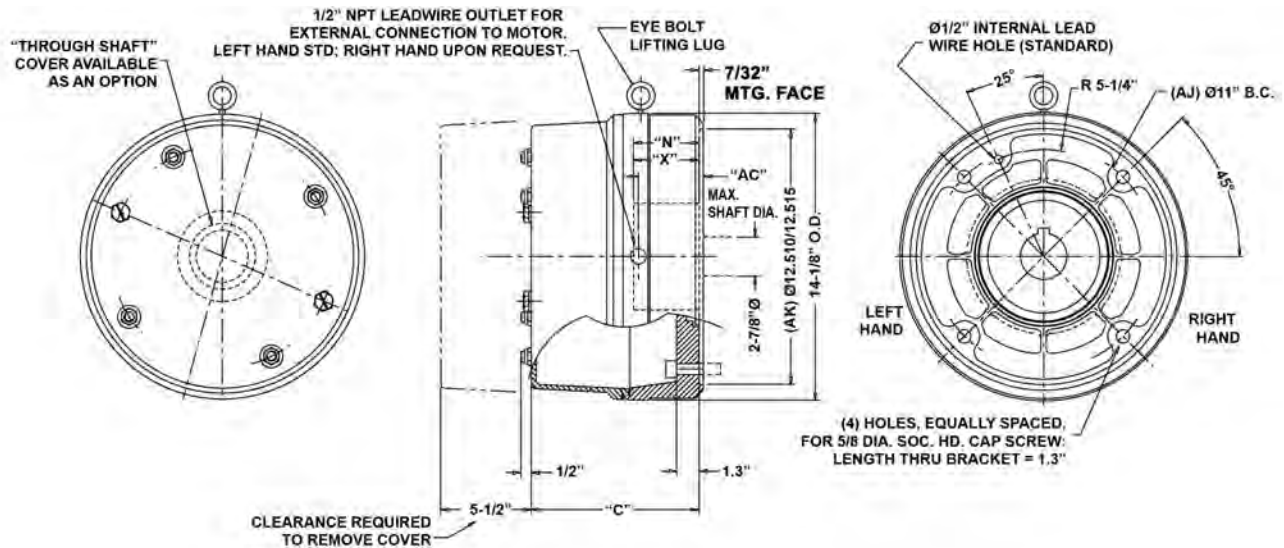

OUTLINE DRAWING, NEMA 4 ENCLOSURE

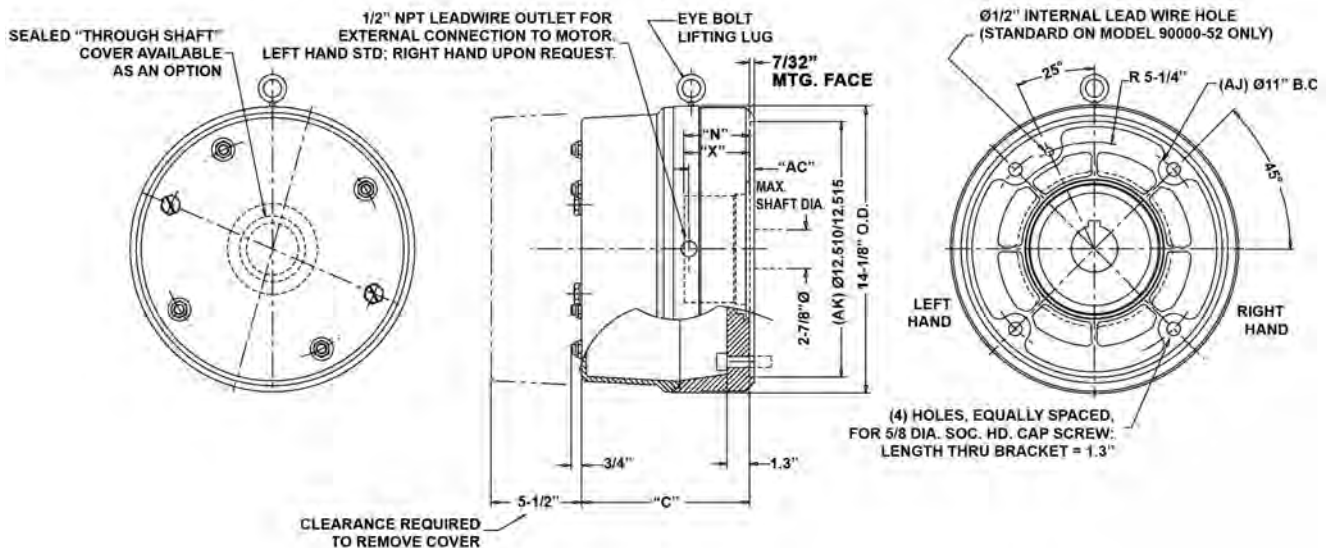

Series 100

8600 Style

NEMA Frame Sizes 444 and 445TC/UC/TSC/USC (16.0" AK, 14.0" AJ)
or 505TC/UC/TSC/USC (16.5" AK, 14.5" AJ)

Torque Ratings: 500 - 1000 lb-ft

Replacement for Stearns®
86,000 and 86,100 Series Brakes

[BACK TO TABLE
OF CONTENTS](#)



**Available
Mid-2020**

Specifications:

Reaction Time: 20-25 milliseconds
(release and set)

444/445 Frame AK: 16.0" Register
AJ: 14.00" Bolt Circle

505TC Frame AK: 16.5" Register
AJ: 14.50" Bolt Circle

Maximum RPM: 1800

CSA File Pending

Coil insulation: Class H

External paint: Red primer

Design Features:

RoHS Compliant

Direct acting design with no linkages to break

Torque adjustable for specific applications

External manual release with automatic reset

One moving part for longer life

Splined hub

Spring set, electrically released

Enclosure Types:

Dripproof Enclosure NEMA 2, CSA 2, IP41

Cast iron

Waterproof/Dusttight Enclosure NEMA 4, CSA 4, IP56

Cast iron

Brake Model Number Definition

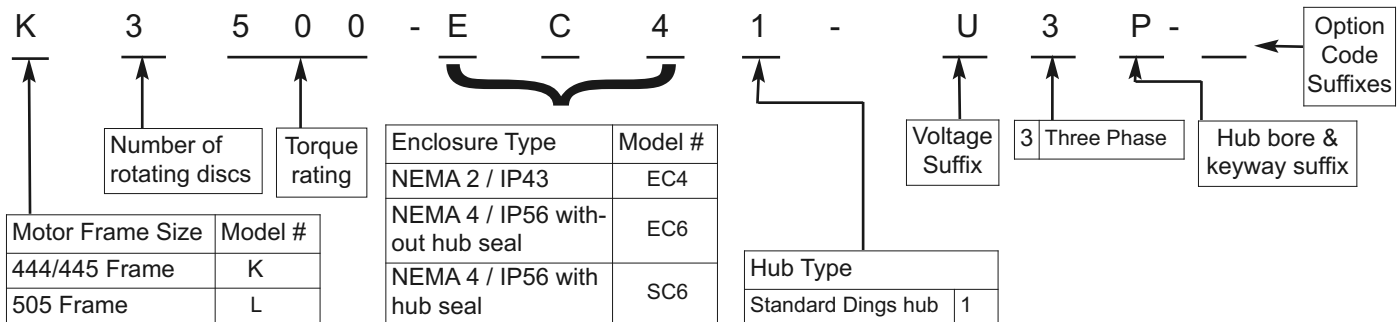

Voltages (three phase only):

Suffix	Voltage
U	230/460V, 60 Hz or 190/380V, 50 Hz
T	220/440V, 60 Hz
P	575V, 60 Hz

Special voltages available.

Hub Bore Sizes:

Suffix	Size	Keyway
P	2 3/8"	5/8" x 5/16"
Q	2 7/8"	3/4" x 3/8"
S	3 3/8"	7/8" x 7/16"
O	3 7/8"	1" x 1/2"

Special bore sizes available.

Stearns® is a Registered Trademark of Rexnord Corporation

Hazardous Location Brakes

[BACK TO TABLE
OF CONTENTS](#)

A hazardous location is an explosive atmosphere due to the presence of flammable gases, vapors, or liquids (Class I), combustible dusts (Class II), or ignitable fibers & flyings (Class III). Dings provides brakes for Division 1, Class I Group C and D, and Division 1, Class II Groups E, F and G, hazardous locations. The National Electrical Code (NEC) defines hazardous locations by Class, Division and Group. For more information about hazardous locations please refer to: <http://www.ul.com/global/eng/pages/offerings/services/hazardouslocations/>.

Hazardous Location Classifications

Class I Locations

Locations in which ignitable concentrations of flammable gases, flammable liquid-produced vapors, or combustible liquid-produced vapors can exist under normal operating conditions. An electric disc brake for Class I locations must be capable of withstanding an explosion of a specified gas or vapor that may occur within it and prevent the ignition of the gas or vapor surrounding the enclosure by sparks, flashes, or explosion of the gas or vapor within, and operate at such an external temperature that a surrounding flammable atmosphere will not be ignited thereby.

Class II Locations

Locations in which combustible dust is in the air under normal operating conditions in quantities sufficient to produce explosive or ignitable mixtures. An electric disc brake for Class II locations must be enclosed in a manner that excludes dusts and does not permit heat generated inside of the enclosure to cause ignition of exterior accumulations of a specified dust on or in the vicinity of the enclosure.

Divisions

Each hazardous-location Class is also divided into two Divisions, 1 and 2. Division 1 brakes can be used in both Division 1 and Division 2 environments. Division 2 brakes can be used in Division 2 environments ONLY. Note that the brake and motor must be rated for the same Division; i.e., a Division 1 brake must be used on a motor which is also rated for Division 1.

Division 1

A Division 1 location is a location where an ignitable concentration of a flammable or combustible material is present under normal operating conditions.

Division 2

A Division 2 location is a location where an ignitable concentration of a flammable or combustible material is present only under abnormal operating condition.

Groups

Class I gases and vapors are listed in four Groups: A, B, C and D. These materials are grouped according to explosion pressure, ignition temperature and the conductivity of the hazardous substance. Class II airborne dusts are listed in three Groups: E, F, and G. These groups are classified according to ignition temperature and electrical conductivity.

Brake Selection

When selecting a Dings hazardous-location disc brake, the Class and Group designations of the hazardous atmosphere and its ignition temperature must be known. For more information on hazardous location responsibilities, see: <http://www.ul.com/global/eng/pages/offerings/services/hazardouslocations/>.

1. Determine the Class and Group designation of the hazardous atmosphere.
2. For Class I hazardous substances, determine the ignition temperature of the explosive gas or vapor.

Select a brake listed for the appropriate group and operating temperature code, with a maximum external operating temperature that does NOT exceed the ignition temperature of the explosive gas or vapor. The operating temperature code for Dings Hazardous Location brakes is T3C. For an explanation of temperature codes refer to: <http://www.ul.com/global/documents/offerings/services/hazardouslocations/CII-Tcodes>.

NOTE: Maximum exterior surface temperature is based on operation in an ambient of 32°F to 104°F (0° to 40°C).

Brake Labels and Listing

Dings brakes for use in hazardous locations are marked to show the Class, Group, and Operating Temperature Code of the brake. Compliance with the NEC is demonstrated by UL Listing of the product in Underwriters Laboratories Hazardous Location Equipment Directory. A label displaying the UL Listing mark and required rating information will be found on each Dings brake to confirm the Listing. In Canada, the Canadian Standards Association (CSA) is an organization with the responsibility to publish and administer national electrical standards as well as to test and certify electrical products. The CSA mark is not on Dings hazardous-location brakes as standard, but can be requested as an option. Dings motor-mounted, hazardous-location electric disc brakes are Listed only when mounted directly to a Listed hazardous-location motor of the same Class and Group at the motor manufacturer's facility, and where the combination has been accepted by UL. This procedure completes the explosion-proof assembly of the brake. However, Listed hazardous-location brakes with a foot mounting option are also available for coupling to a motor, and may be installed by anyone. Installation and servicing must be in compliance with all existing local safety codes. All wiring and electrical connections must comply with the National Electric Code (NEC) and local electrical codes in effect at the time. For additional information see the UL website: <http://www.ul.com/hazloc/codes/html>. Hazardous Location inspection authorities are responsible for verifying and authorizing the use of suitably designed, manufactured and installed Hazardous Location equipment. When questions arise always consult the local Authority Having Jurisdiction (AHJ) for directions and approvals. Dings Division 1 hazardous location brakes are provided without gaskets. If the brake is used in a high humidity or low temperature environment, internal electric heaters should be used.

NOTE: Foot mount required for hazardous location brakes if purchased by other than a U.L. authorized electric motor manufacturer or shop. Brakes used with a foot mount are suitable for use in Division 1 or Division 2 applications.

3. For Class II hazardous substances, select a brake listed for the appropriate group and operating temperature code. The operating temperature code for Dings Hazardous Location brakes is T3C. For an explanation of temperature codes refer to: <http://www.ul.com/global/documents/offerings/services/hazardouslocations/CII-Tcodes>.

NOTE: Maximum exterior surface temperature is based on operation in an ambient of 32°F to 104°F (0° to 40°C).

Thermal Considerations

One of the design requirements of hazardous location brakes is to limit exterior surface temperature. The surface temperature of the enclosure must not exceed a specified limit as a result of heat energy created in stopping the motor and load. This NEC restriction on the exterior surface temperature limits the hazardous-location brake's ability to dissipate heat, resulting in less thermal capacity than a comparable brake with a standard or dust-tight, waterproof enclosure. **THEREFORE, HAZARDOUS-LOCATION BRAKES ARE INTENDED ESSENTIALLY FOR NON-CYCLIC OR HOLDING PURPOSES, BUT MAY BE USED FOR STOPPING LIGHT INERTIAL LOADS.**

60 Series Hazardous Location

DIVISION 1 HAZARDOUS LOCATION

NEMA Frame Sizes 56C through 145TC

Torque Ratings: 1.5 to 15 lb-ft



RoHS Compliance upon request- can be constructed to meet the requirements of the Restriction of Hazardous Substances Directive

Specifications:

Reaction Time: 15-20 milliseconds (release and set)
 AK: 4.5" Register
 AJ: 5.88" Bolt Circle
 Maximum RPM: 3600
 Coil insulation: Class B
 Instructions and Parts Manual: BK4614

Enclosure Types:

Cast iron cover and bracket

Enclosure Protection:

NEMA 2, and Hazardous Location NEMA 7, 9

Certifications:

CSA File No. LR 19464 (CSA nameplate upon request)
 UL File No. E27811 Class I Group C and D, Class II Groups E, F, and G

[BACK TO TABLE OF CONTENTS](#)

Design Features:

Torque adjustable for specific applications
 Splined hub
 Spring set, electrically released
 Manual release, automatic reset

NOTE: Foot mount required for hazardous location brakes if purchased by other than a U.L. authorized electric motor manufacturer or shop. Brakes used with a foot mount are suitable for use in Division 1 or Division 2 applications.

Special Note: Dings 60 Series Hazardous Location Brakes are equipped with a thermal overload release mechanism. When the external surface of the brake approaches the specified temperature limit, the mechanism will automatically release the brake and hold it in the released position. This prevents the surface temperature from rising to a level that could ignite surrounding gases or dust by releasing the brake and thereby stopping a further increase in temperature.

Caution: Once the brake has been released by the thermal overload mechanism, control over the rotation of the motors and movement of the load is lost. This uncontrolled rotation of the motor and movement of the load could cause injury to personnel and damage to property.

Dings 60 Series Hazardous Location Brakes are also equipped with a thermal switch. When properly wired into the motor starting circuit, the thermal switch shuts down the motor before the thermal overload mechanism releases the brake. When the thermal switch activates, it stops the motor and load, preventing the uncontrolled motion described in the "caution" above. See bulletin BK4614X.

Brake Model Number Definition

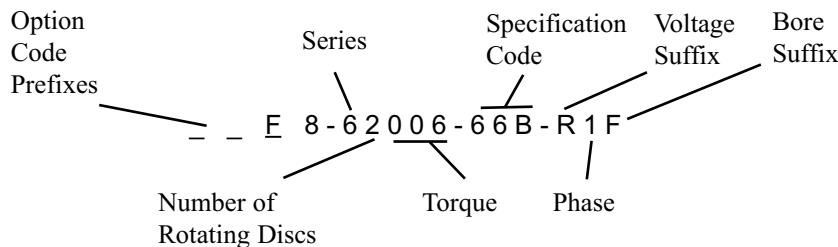

Standard Hub Bore Sizes:		
Suffix	Size	Keyway
D	5/8"	3/16" x 3/32"
E	3/4"	3/16" x 3/32"
F	7/8"	3/16" x 3/32"
G	1"	3/16" x 3/32"
H	1 1/8"	1/4" x 1/8"

Special bore sizes available.

Standard Voltages	
(Single phase only):	
Suffix	Voltage
Y	110/220V, 50Hz
U	230/460V, 60 Hz or 190/380V, 50 Hz
R	115/230V, 60 Hz
T	220/440V, 60 Hz
P	575V, 60 Hz

Special voltages available.

Available Options:	Prefix
Foot Mounting Bracket	F
Heavy-Duty Rotating Friction Disc with Hardened Steel Hub	H
Vertical Mounting	
Vertical Over, or above motor	VO
Vertical Under, or below motor	VU

Refer to pages 51-56 for option descriptions & pricing.

DIVISION 1 HAZARDOUS LOCATION

[BACK TO TABLE OF CONTENTS](#)

Torque lb-ft	Dings Model #	Replacement for Stearns® Model (NOTE1)	Construction	Wt. Lbs.	Thermal Capacity HPS/MIN*	Inertia WK ² Lb.Ft. ²	Dimensions in inches				List Price without foot mount	List Price with foot mount
							C	AH		AC		
								Max.	Min.			
1.5	F8-61001-66B	1-065-311-05	Cast Iron	42	6	0.020	7 15/16	2 3/8	1 3/4	2 1/16	\$	\$
3	F8-61003-66B	1-065-321-05	Cast Iron	42	6	0.020	7 15/16	2 3/8	1 3/4	2 1/16	\$	\$
6	F8-62006-66B	1-065-331-05	Cast Iron	44	6	0.030	8 5/16	2 3/4	2	2 7/16	\$	\$
10	F8-63010-66B	1-065-351-05	Cast Iron	47	6	0.040	8 11/16	3 1/8	2 1/4	2 13/16	\$	\$
15	F8-63015-66B	1-065-361-05	Cast Iron	47	6	0.040	8 11/16	3 1/8	2 1/4	2 13/16	\$	\$

*Hazardous location brakes are intended for non-cyclic or holding purposes only, but may be used for stopping light inertial loads.

NOTE 1: Not a direct drop-in for Stearns models; review outline drawing and dimensions, and specifications

Stearns® is a Registered Trademark of Rexnord Corporation

BRAKE DIMENSIONS

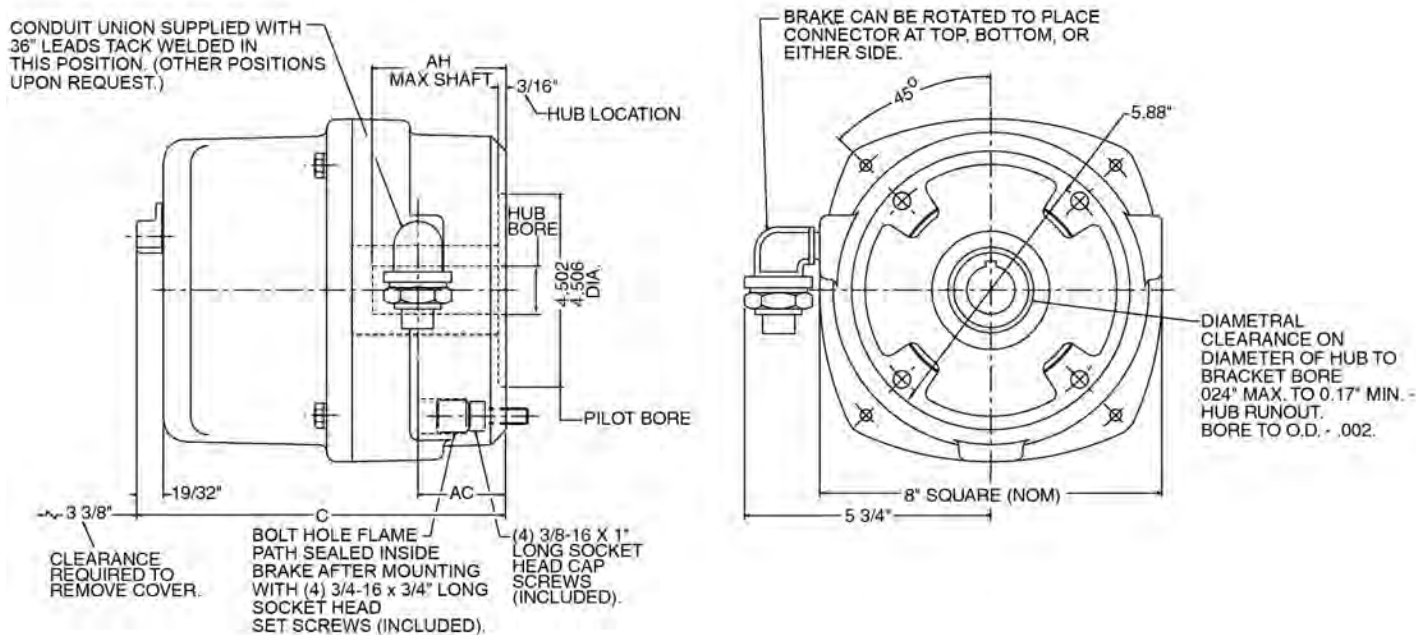

Hazardous location brakes are provided with a foot mounting bracket.

FOOT MOUNTING BRACKET DIMENSIONS

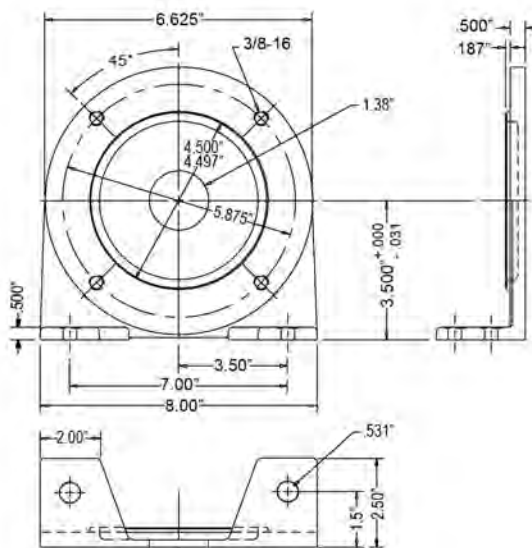

70 Series Hazardous Location

DIVISION 1 HAZARDOUS LOCATION

NEMA Frame Sizes 182TC through 256TC

Torque Ratings: 10 to 75 lb-ft



RoHS Compliance upon request- can be constructed to meet the requirements of the Restriction of Hazardous Substances Directive

Specifications:

Reaction Time: 20-25 milliseconds (release and set)

AK: 8.5" Register

AJ: 7.25" Bolt Circle

Maximum RPM: 3600

Coil insulation: Class B Std., Class H Optional

Instructions and Parts Manual: BK4606

Enclosure Types:

Cast iron cover and bracket R70000-9

Enclosure Protection:

NEMA 2, and Hazardous Location NEMA 7, 9

Certifications:

CSA File No. LR 19464 (CSA nameplate upon request)

UL File No. E27811 Class I Group C and D, Class II Groups E, F, and G

[BACK TO TABLE OF CONTENTS](#)

Design Features:

Torque adjustable for specific applications

Splined hub

Spring set, electrically released

Manual release, automatic reset

NOTE: Foot mount required for hazardous location brakes if purchased by other than a U.L. authorized electric motor manufacturer or shop. Brakes used with a foot mount are suitable for use in Division 1 or Division 2 applications.

Special Note: Dings 70 Series Hazardous Location Brakes are equipped with a thermal overload release mechanism. When the external surface of the brake approaches the specified temperature limit, the mechanism will automatically release the brake and hold it in the released position. This prevents the surface temperature from rising to a level that could ignite surrounding gases or dust by releasing the brake and thereby stopping a further increase in temperature.

Caution: Once the brake has been released by the thermal overload mechanism, control over the rotation of the motors and movement of the load is lost. This uncontrolled rotation of the motor and movement of the load could cause injury to personnel and damage to property.

Brake Model Number Definition

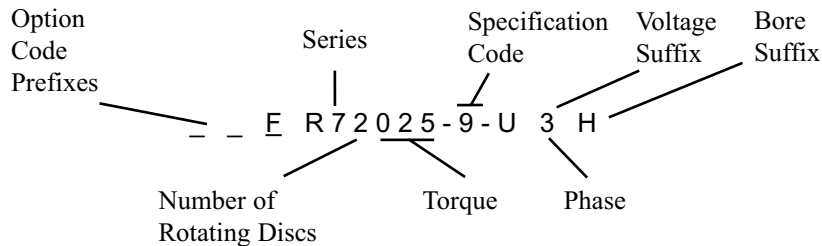

Standard Hub Bore Sizes:

Suffix	Size	Keyway
F	7/8"	3/16" x 3/32"
G	1"	3/16" x 3/32"
H	1 1/8"	1/4" x 1/8"
J	1 1/4"	1/4" x 1/8"
K	1 3/8"	5/16" x 5/32"
L	1 1/2"	3/8" x 3/16"
M	1 5/8"	3/8" x 3/16"

Special bore sizes available.

Standard Voltages

(Single or three phase):

Suffix	Voltage
Y	110/220V, 50Hz
U	230/460V, 60 Hz or 190/380V, 50 Hz
R	115/230V, 60 Hz
T	220/440V, 60 Hz
P	575V, 60 Hz

Special voltages available.

Available Options:

Option	Prefix
Foot Mounting Bracket	F
Heavy-Duty Rotating Friction Disc with Hardened Steel Hub	H
Class H Insulation	Q
Internal Space Heater	R
Vertical Mounting	
Vertical Over, or above motor	VO
Vertical Under, or below motor	VU

Refer to pages 51-56 for option descriptions & pricing.

DIVISION 1 HAZARDOUS LOCATION

Torque lb-ft	Model #	Replacement for Stearns® Model (NOTE1)	Construction	Wt. Lbs.	Thermal Capacity HPS/MIN*	Inertia WK ² Lb.Ft. ²	Dimensions in inches			List Price without foot mount	List Price with foot mount	
							C	AH				AC
							Max.	Min.				
10	FR71010-9	1-087-311-00	Cast Iron	69	10	0.035	10 5/8	3 7/16	2 3/8	3 13/32	\$	\$
15	FR71015-9	1-087-321-00	Cast Iron	69	10	0.035	10 5/8	3 7/16	2 3/8	3 13/32	\$	\$
25	FR72025-9	1-087-331-00	Cast Iron	74	11	0.076	11 1/4	3 3/4	2 5/8	4 1/32	\$	\$
35	FR73035-9	1-087-341-00	Cast Iron	79	12	0.102	11 7/8	4 3/8	3	4 21/32	\$	\$
50	FR74050-9	1-087-351-00	Cast Iron	84	13	0.130	12 1/2	5 1/8	3 1/2	5 9/32	\$	\$
75	FR75075-9	1-087-361-00	Cast Iron	84	13	0.115	12 1/2	5 1/8	3 1/2	5 9/32	\$	\$

*Hazardous location brakes are intended for non-cyclic or holding purposes only, but may be used for stopping light inertial loads.

NOTE 1: Not a direct drop-in for Stearns models; review outline drawing and dimensions, and specifications.

Stearns® is a Registered Trademark of Rexnord Corporation

BRAKE DIMENSIONS

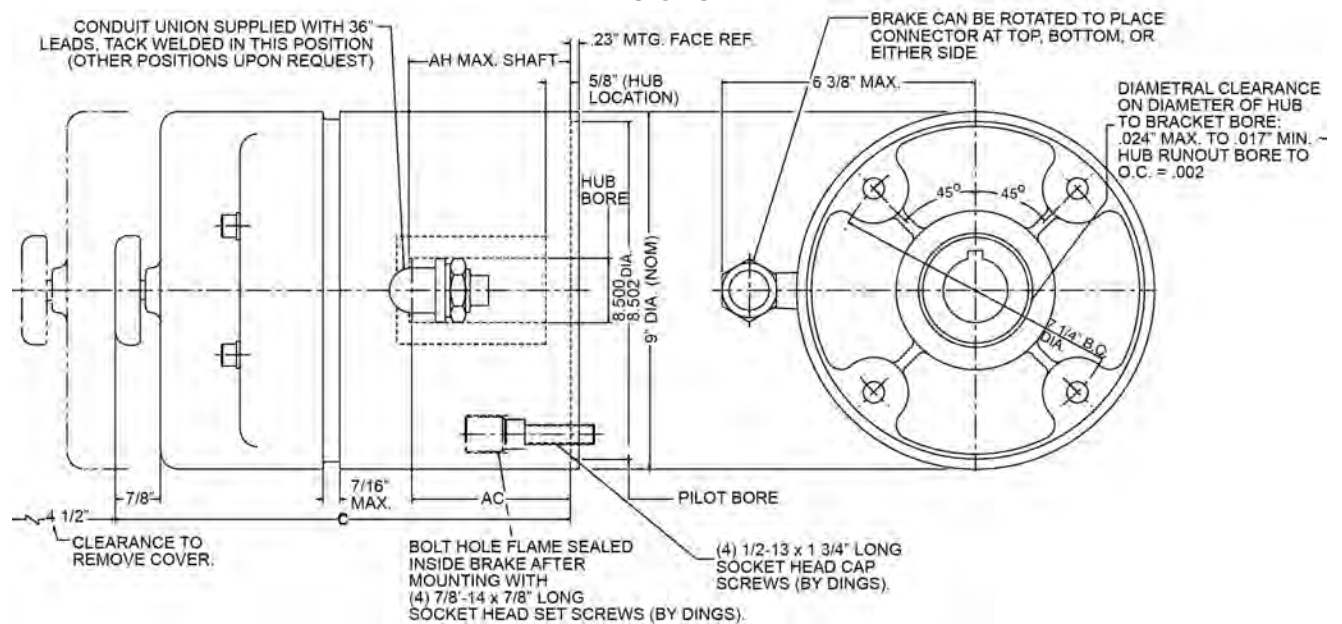

Hazardous location brakes are provided with a foot mounting bracket.

FOOT MOUNTING BRACKET DIMENSIONS

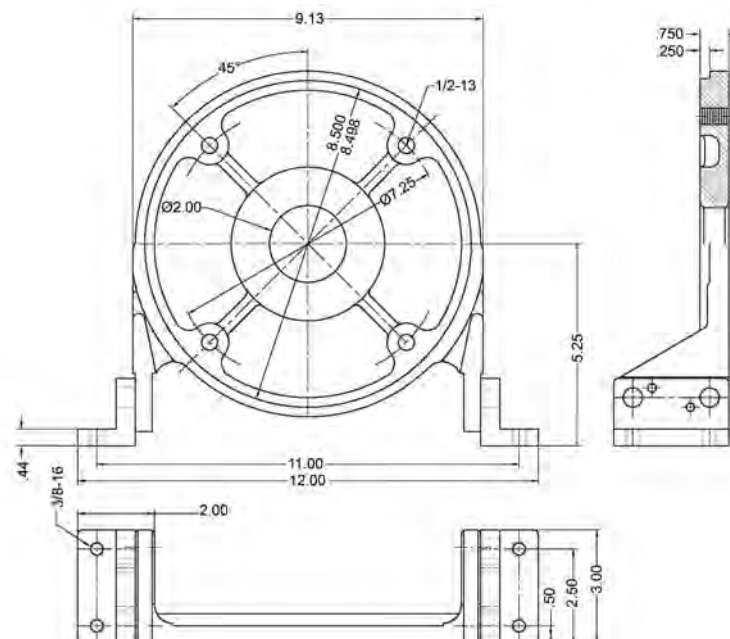

Marine/Maritime Duty Brakes

Torque Ratings: 1.5 to 450 lb-ft

Dings Marine duty brakes are suitable for many shipboard, dockside and severe duty applications where water, salt water and salt vapor exist.

[BACK TO TABLE OF CONTENTS](#)

STANDARD FEATURES

- Enclosure Rating: IP56/NEMA 4X
- Compliant with IEEE 45.
IEEE 45 nameplate must be requested
- Housing Material: Cast Iron (ductile iron optional)
- Pressure Plate: Plated Steel
- Stationary Disc: Steel
- Plated hardware
- Manual Release is maintained with automatic reset
- Coil Insulation: Class B or Class H, see specific brake series
- Housing exterior and interior are painted with a primer and high solid epoxy paint (non-military). For MIL-SPEC paint, see OPTIONS
- Interior parts are zinc plated or painted.
- Hub seals included

60 Series – 56C - 143/145TC

Torque lb-ft.	Model No.	Coil Insulation	List Price
1.5	N61001-530	B	\$
3	N61003-530	B	\$
6	N61006-530	B	\$
10	N62010-530	B	\$
15	N63015-530	B	\$
20	N63020-530	H	\$
25	N64025-530	H	\$



70 Series – 182TC - 256TC

HEAVY DUTY 4 Post Design

Torque lb-ft.	Model No.	Coil Insulation	List Price
10	N71010-SC61	H	\$
15	N71015-SC61	H	\$
25	N72025-SC61	H	\$
35	N72035-SC61	H	\$
50	N73050-SC61	H	\$
75	N74075-SC61	H	\$
105	N74105-SC61	H	\$



80 Series – 284TC/286TC

HEAVY DUTY 4 Post Design

Torque lb-ft.	Model No.	Coil Insulation	List Price
25	N81025-29	H	\$
35	N81035-29	H	\$
50	N82050-29	H	\$
75	N83075-29	H	\$
105	N83105-29	H	\$
125	N84125-29	H	\$
175	N84175-29	H	\$



90 Series – 324TC-405TC

HEAVY DUTY 4 Post Design

Torque lb-ft.	Model No.	Coil Insulation	List Price
125	N92125-51	H	\$
180	N92180-51	H	\$
270	N93270-51	H	\$
360	N94360-51	H	\$
450	N95450-51	H	\$



Model Number Example

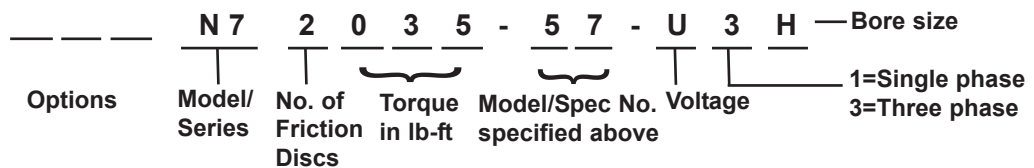

OPTIONS Description	Prefix	List Price Adder			
		Series			
		60	70	80	90
Class H insulation	Q	\$	Std	Std	Std
Space heater	R	\$	\$	\$	\$
Breather drain	K	\$	\$	\$	\$
Tropical protection	P	\$	\$	\$	\$
Stainless steel stationary disc (add per disc)	S	\$	\$	\$	\$
Stainless hardware	X	\$	\$	\$	\$
Military primer & top coat per TT-P-645 & MIL-DTL-15090	M	\$	\$	\$	\$
Heavy duty friction discs 1st disc and hardened hub Each add'l disc	H	\$	\$	\$	\$
Ductile iron enclosure	X	\$	N/A	\$	\$

Suffix	Voltage
Y	110/220V, 50Hz
U	230/460V, 60 Hz or 190/380V, 50 Hz
R	115/230V, 60 Hz
T	220/440V, 60 Hz
P	575V, 60 Hz

Suffix	Size	Series
D	5/8"	60
F	7/8"	60,70,80
H	1 1/8"	70,80
J	1 1/4"	70,80
K	1 3/8"	70,80
M	1 5/8"	70,80
N	1 7/8"	80
O	2 1/8"	90
P	2 3/8"	90
Q	2 7/8"	90

Naval Service

[BACK TO TABLE OF CONTENTS](#)

NEMA Frame Sizes 182TC through 286TC
Torque Ratings: 3 to 180 lb-ft

Specifications:

70 Series

Reaction Time: 15-20 milliseconds (release & set)
 AK: 8.5" Register AJ: 7.25" Bolt Circle
 Maximum RPM: 3600

80 Series

Reaction Time: 20-25 milliseconds (release & set)
 AK: 10.5" Register AJ: 9.00" Bolt Circle
 Maximum RPM: 2400

Conforms to MIL-B-16392 specifications

Design Features:

- Splined hub
- Deadman release
- 36" leadwire length
- Spring set, electrically released
- Aluminum bronze stationary discs
- Ductile iron construction
- Torque adjustable for specific applications
- Coil insulation: Class B Standard, Class H Optional
 (Class H standard on 80 Series single phase)
- Housing exterior and interior are primed and top coated per MIL-E-917. Internal parts are zinc plated or painted. Meets IEEE 45 and CFR110.1-1 standards.
- Also available* - nonmagnetic construction
 - 70 Series nonmagnetic model 70000-85
 - 80 Series nonmagnetic model 80000-51

70 Series—Frame Sizes 182TC - 256TC

Torque lb-ft	Model #	Wt. Lbs.	Thermal Capacity HPS/MIN	Inertia WK ² Lb-ft ²	List Price
3	71003-42	54	11	0.028	\$
10	71010-42	54	11	0.028	\$
15	71015-42	54	11	0.028	\$
25	72025-42	58	12	0.051	\$
35	72035-42	58	12	0.051	\$
50	73050-42	62	13	0.075	\$
75	74075-42	66	14	0.099	\$



80 Series—Frame Sizes 284TC and 286TC

Torque lb-ft	Model #	Wt. Lbs.	Thermal Capacity HPS/MIN	Inertia WK ² Lb-ft ²	List Price
25	81025-27	80	15	0.084	\$
35	81035-27	80	15	0.084	\$
50	82050-27	86	17	0.158	\$
75	83075-27	90	19	0.233	\$
90	83090-27	90	19	0.233	\$
135	84135-27	97	21	0.309	\$
180	85180-27	104	21	0.384	\$



Motor Frame Adaptors

[BACK TO TABLE OF CONTENTS](#)

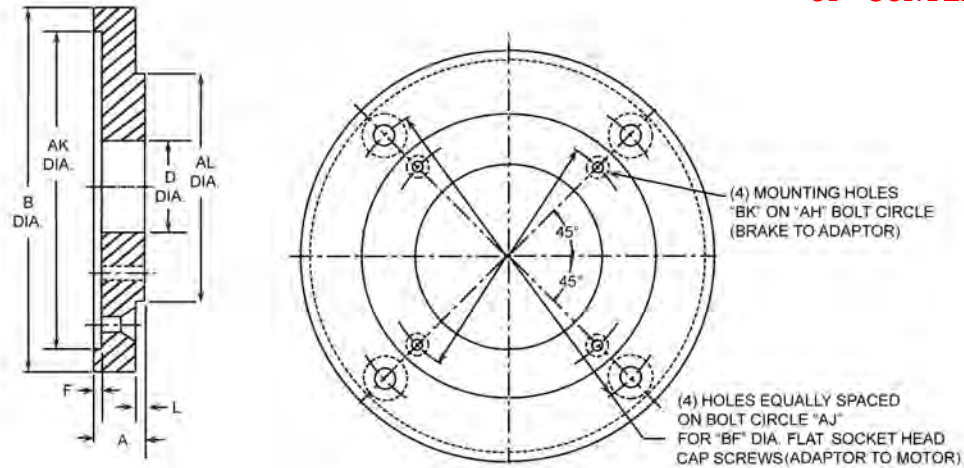

Brake Series	NEMA C Face BRAKE SIDE	NEMA C Face MOTOR SIDE	Brake Bracket Material	Brake Model Prefix	Adaptor Part Number	Dimensions in inches										
						A	AH	AJ	AK	AL	B	BF	BK	D	F	L
60	56C, 143TC, 145TC	182TC-256TC	Aluminum	A	G060539-001	0.75	5.88	7.25	8.50	4.50	9.00	1/2-13	3/8-16	4.00	0.19	0.12
		182TC-256TC	Cast Iron	A	G060540-001	0.75	5.88	7.25	8.50	4.50	9.00	1/2-13	3/8-16	4.00	0.19	0.12
60 Hazardous Location	56C, 143TC, 145TC	182TC-256TC	Aluminum	A	G060552-001	0.75	5.88	7.25	8.50	4.50	9.00	1/2-13	3/8-16	4.00	0.19	0.13
		182TC-256TC	Cast Iron	A	G060553-001	0.75	5.88	7.25	8.50	4.50	9.00	1/2-13	3/8-16	4.00	0.19	0.12
70	182TC-256TC	284-286TC/UC	Cast Iron	A	G070558-001	1.09	7.25	9.00	10.50	8.50	11.00	1/2-13	1/2-13	8.00	0.23	0.25
		324TC-405TC	Cast Iron	AA	G070535-001	1.09	7.25	11.00	12.50	8.50	13.00	5/8-11	1/2-13	6.00	0.23	0.25
70 Hazardous Location	182TC-256TC	284-286TC/UC	Cast Iron	A	G070534-001	1.09	7.25	9.00	10.50	8.50	11.00	1/2-13	1/2-13	8.00	0.23	0.25
80	284-286TC/UC	324TC-405TC	Cast Iron	A	G080202-001	1.22	9.00	11.00	12.50	10.50	13.00	1/2-13	1/2-13	10.00	0.23	0.25
		444-445TC/UC	Cast Iron	AA	G080203-001	1.09	9.00	9.00	10.50	10.50	16.50	5/8-11	1/2-13	8.00	0.23	0.25
90	324TC-405TC	444-445TC/UC	Cast Iron	A	L090018-001	1.74	11.00	14.00	16.00	12.50	17.00	5/8-11	5/8-11	12.00	0.25	0.25
		505TC/UC	Cast Iron	AA	L090018-002	1.74	11.00	14.50	16.50	12.50	17.00	5/8-11	5/8-11	12.00	0.25	0.25

Reverse Adaptors

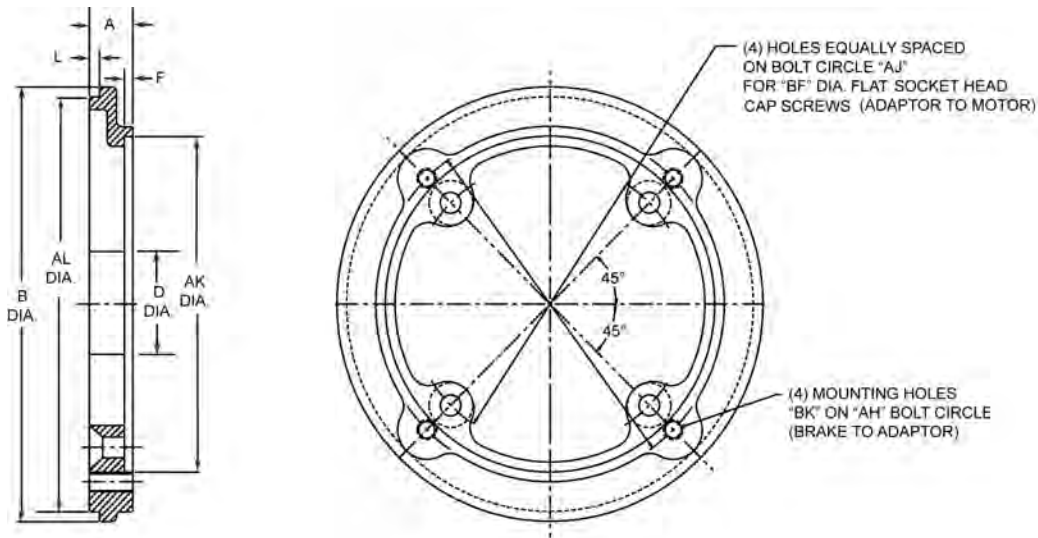

Brake Series	NEMA C face BRAKE SIDE	NEMA C face MOTOR SIDE	P/N Prefix	Adaptor Part Number	Dimensions in inches										
					A	AH	AJ	AK	AL	B	BF	BK	D	F	L
60	56C, 143TC, 145TC	48C	AB	G060546-001	0.50	5.88	3.75	3.00	4.50	6.50	1/4-20	3/8-16	3.00	0.50	0.13
70	182TC-256TC	56C, 143TC, 145TC	AB	G070560-001	0.50	7.25	5.88	4.50	8.50	8.50	3/8-16	1/2-13	4.50	0.50	0.50
70 Hazardous Location	182TC-256TC	56C, 143TC, 145TC	AB	G070536-001	0.50	7.25	5.88	4.50	8.50	8.50	3/8-16	1/2-13	4.50	0.50	0.50
80	284-286TC/UC	182TC-256TC	AB	G080204-001	1.09	9.00	7.25	8.50	10.50	11.00	1/2-13	1/2-13	8.00	0.22	0.25
90	324TC-405TC	284-286TC/UC	AB	G090238-001	0.88	11.00	9.00	10.50	12.50	12.50	1/2-13	1/2-13	7.75	0.22	0.66

Foot Mounting Brackets

[BACK TO TABLE OF CONTENTS](#)

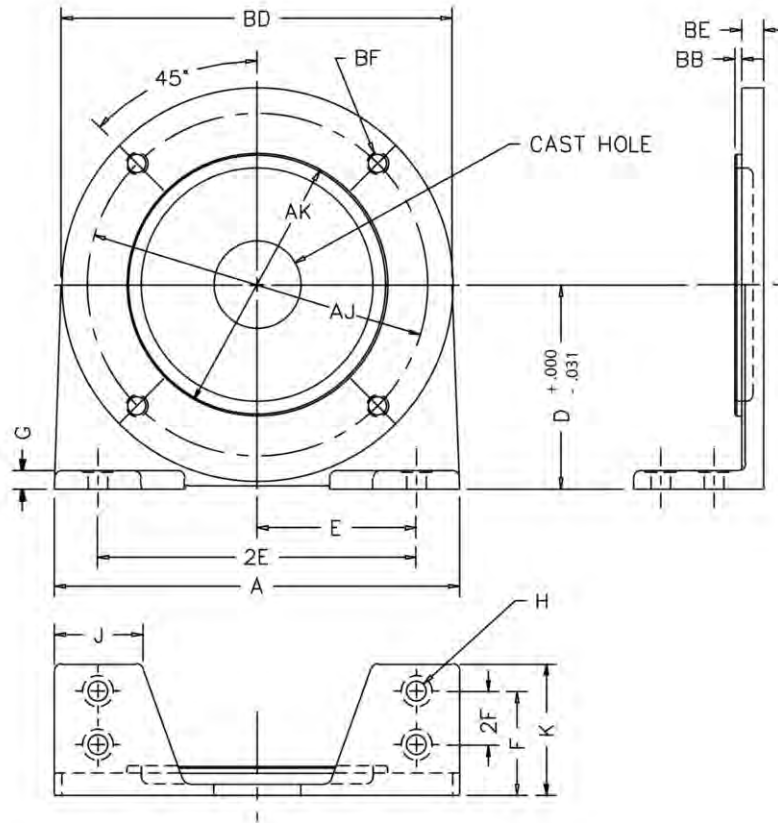

Brake Series	Foot Mounting Kit	Dimensions in inches							
		A	AJ	AK	BB	BD	BE	BF	D
60	G060559-001	8.00	5.88	4.500/4.497	.19	6.63	.50	3/8-16	3.50
70	G070561-001	9.00	7.25	8.500/8.497	.25	9.00	.50	1/2-13	5.00
80	G080208-001	11.00	9.00	10.500/10.497	.25	11.00	.50	1/2-13	6.00
90	G090288-001	20.00	11.00	12.500/12.497	.28	14.00	1.50	5/8-11	8.25
60 Hazardous Location	G060559-001	8.00	5.88	4.500/4.497	.19	6.63	.50	3/8-16	3.50
70 Hazardous Location	G070545-001	9.00 OR 12.50	7.25	8.500/8.498	.25	9.00	.50	1/2-13	5.00

Brake Series	Torque lb-ft	Bracket Weight lbs.	Dimensions in inches									
			E	2E	F	2F	G	H (Hole)		J	K	Cast Hole
								Dia.	Qty.			
60	1.5-25	7	3.500	7.00	1.50	-	.500	.531	2	2.00	2.50	1.38
70	10-70	8	3.500	7.00	2.00	-	.437	.656	2	2.00	3.00	1.75
80	25-175	12	4.250	8.50	2.00	-	.500	.656	2	2.50	3.00	3.50
90	125-450	78	9.000	18.00	5.50	4.50	.937	.656	4	3.00	6.50	4.00
60 Hazardous Location	1.5-15	7	3.500	7.00	1.50	-	.500	.531	2	2.00	2.50	1.38
70 Hazardous Location	10-75	11	2.750 OR 5.812	5.50 OR 11.63	2.50	-	.500	.656	2	1.75	3.00	2.00

Brake Options

[BACK TO TABLE OF CONTENTS](#)

A Adaptor to Next Larger Size



List Price Adders:

50 Series	\$
60 Series End Mount	\$
60 Series Double C Face	\$
60 Series Hazardous	\$
70 Series End Mount	\$
70 Series Double C Face	\$
70 Series Hazardous	\$
80 Series	\$
90 Series	\$

Increases C face dimension to allow mounting to next larger motor frame size.

AB Reverse Adaptor to Next Smaller Size



List Price Adders:

60 Series End Mount	\$
60 Series Double C Face	\$
60 Series Hazardous	\$
70 Series End Mount	\$
70 Series Double C Face	\$
70 Series Hazardous	\$
80 Series	\$
90 Series	\$

Reduces C face dimension to allow mounting to next smaller motor frame size.

B Aluminum Bronze Stationary Disc



List Price Adders:

70 Series End Mount (N/A on 8700 Style)	\$/disc
80 Series	\$/disc
90 Series	\$/disc

Provides extra corrosion resistance.

C Conduit Box



List Price Adders:

60 Series	\$
70 Series	\$
80 Series	\$
90 Series	\$

External junction box to connect brake leads. No terminal blocks included unless requested.

DD DC Voltage



List Price Adders:

40 Series	\$
50 Series	\$
60 Series End Mount	\$
60 Series Double C Face	\$
1-70 Series End Mount	\$

Special coil and electronic circuit allows brake to operate on DC voltage. Not intended for half wave rectified DC power.

E Ductile Iron Stationary Disc



List Price Adders:

70 Series End Mount (N/A on 8700 Style)	\$/disc
70 Series Double C Face	\$/disc
80 Series	\$/disc

Ductile iron provides greater strength for high cycle applications.

Brake Options

[BACK TO TABLE OF CONTENTS](#)

F Foot Mounting Bracket



List Price Adders:

60 Series End Mount	\$
60 Series Double C Face	\$
60 Series Hazardous	\$
70 Series End Mount	\$
70 Series Double C Face	\$
70 Series Hazardous	\$
80 Series	\$
90 Series	\$

Allows brake to be supported without having to be mounted to a motor C Face.

H Heavy Duty Rotating Friction Disc with Hardened Steel Hub



Single Disc Brake

List Price Adders:

60 Series End Mount	\$
60 Series Double C Face	\$
60 Series Hazardous	\$
70 Series End Mount	\$
70 Series Double C Face	\$
70 Series Hazardous	\$
80 Series	\$
90 Series	\$

Additional Adders (Per Disc):

60 Series	\$
70 Series	\$
80 Series	\$
90 Series	\$

Metal disc center provides extra tooth support for high cycle/shock applications.

J High Tensile Stud



List Price Adders:

70 Series End Mount	\$
(N/A on 8700 Style)	
80 Series	\$

Studs are made from high strength steel for use in high cycle/shock applications.

K External Breather



List Price Adders:

60 Series End Mount	\$
70 Series End Mount	\$
80 Series	\$
90 Series	\$

Prevents ingress of moisture in humid conditions, reducing corrosion.

M Marine/Maritime Duty Brake with MIL-SPEC paint per TT-P-645 & MIL-DTL-15090

Special **Military spec.** enamel paint along with plating or painting of interior components provides additional corrosion protection for brakes exposed to severe weather conditions. Meets IEEE 45, CFR110.1-1 standards.

List Price Adders:

60 Series End Mount	\$
60 Series Double C Face	\$
70 Series End Mount	\$
70 Series Double C Face	\$
80 Series	\$
90 Series	\$

N Marine/Maritime Duty Brake

High Solids epoxy paint along with plating or painting of interior components provides additional corrosion protection for brakes exposed to severe weather conditions. Intended for **non-military** offshore applications.

List Price Adders:

60 Series End Mount	\$
60 Series Double C Face	\$
70 Series End Mount	\$
70 Series Double C Face	\$
80 Series	\$
90 Series	\$

Brake Options

[BACK TO TABLE OF CONTENTS](#)

P Tropical Protection

Special anti-fungal coating on electrical coils provides protection for brakes exposed to hot, humid conditions.

List Price Adders:	
60 Series	\$
70 Series	\$
80 Series	\$
90 Series	\$

Q Class H Coil Wire Insulation



High temperature coil wire insulation for extra thermal protection in high temperature applications.

List Price Adders:	
50 Series	\$
60 Series End Mount	\$
60 Series Double C Face	\$
70 Series End Mount	\$
70 Series 8700 Style	Standard
70 Series Double C Face	\$
80 Series	Standard
90 Series	Standard

R Heater



Special resistor helps dissipate moisture in brakes exposed to cold or humid conditions.

List Price Adders:	
60 Series End Mount	\$
60 Series Double C Face	\$
70 Series End Mount	\$
70 Series Double C Face	\$
80 Series	\$
90 Series	\$

S Stainless Steel Stationary Disc



High quality stainless steel discs provide extra corrosion resistance.

List Price Adders:	
60 Series End Mount	\$/disc
70 Series End Mount	\$/disc
80 Series	\$/disc
90 Series	\$/disc

T Through Shaft



Special cover allows shaft to continue through the brake enclosure.

Series	List Adder	Enclosure
40	\$	NEMA 2, IP40
50	\$	NEMA 2, IP40
60	\$	Steel Cover NEMA 2, IP41
60	\$	Cast Iron Cover NEMA 2, IP41
60	\$	Cast Iron Cover NEMA 4, IP54
70	\$	Steel Cover NEMA 2, IP41
70	\$	Cast Iron Cover NEMA 2, IP41
70	\$	Cast Iron Cover NEMA 4, IP54
80	\$	Steel Cover NEMA 2, IP41
80	\$	Cast Iron Cover NEMA 2, IP41
80	\$	Cast Iron Cover NEMA 4, IP54
90	\$	NEMA 2
90	\$	NEMA 4

VO/VU Vertical Over/Vertical Under Mounting

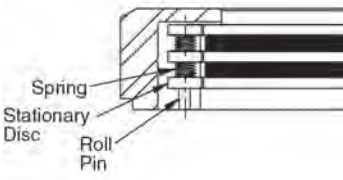

Special springs stabilize discs allowing brake to be mounted in a vertical position either over or under the motor.

List Price Adders (Per Disc):	
60 Series End Mount	\$
70 Series Vertical Over	\$
70 Series Vertical Under	\$
80 Series	\$
90 Series (NEW)	\$

Brake Options

[BACK TO TABLE OF CONTENTS](#)

XE *Smart Brake* Encoder Brake

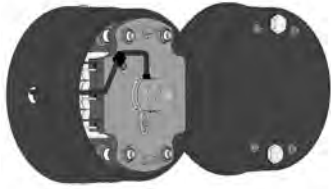

List Price Adders:

60 Series End Mount	\$
70 Series End Mount	\$
80 Series	\$
90 Series	\$

Internally mounted encoder provides feedback on brake positioning and speed. Pricing includes Encoder Products Company Model 260 encoder. For encoder details or for other encoders, contact factory.

XS Microswitch Warning



List Price Adders:

60 Series End Mount	\$
60 Series Double C Face	\$
70 Series End Mount	\$
70 Series Double C Face	\$
80 Series	\$
90 Series	\$

Switch provides a NO/NC contact to alert when brake is released electrically or manually.

XT Tach Machining



List Price Adders:

60 Series End Mount	\$
70 Series End Mount NEMA 2	\$
70 Series End Mount NEMA 4	\$
80 Series End Mount NEMA 2	\$
80 Series End Mount NEMA 4	\$
(Models with cast iron covers only)	

Machined face on cover allows mounting of tachometer or resolver.

External Manual Release MARK II Design



List Price Adders:

70 Series End Mount	\$
(N/A on 8700 Style)	
80 Series	\$

Single point, hand activated, external release lever. Manually set / automatically reset by manually

deactivating or energizing the brake. Available on brakes with cast covers only.

External Manual Release MARK III Design



List Price Adders:

70 Series End Mount	\$
(N/A on 8700 Style)	
80 Series	\$

Dual, hand activated, external release knobs. Manually set / automatically

reset by manually deactivating or energizing the brake. Available on brakes with cast covers only.

Brake Option List Price Additions

[BACK TO TABLE
OF CONTENTS](#)

	Specification Number→	40 Series	50 Series	60 Series							1-70 Series	
		NEMA 2	NEMA 2	NEMA 2			NEMA 4		NEMA 4X		Haz Location	NEMA 2
		End Mount	End Mount	End Mount	End Mount	CC	End Mount	CC	End Mount	CC	End Mount	End Mount
		-012 -013	-050 -05A	-524	-5601 -5602 -5603 -5604	-551	-530 -535 -543 -545	-5153	-5115 -5116 -5140 -5141	-5145 -5155	-66B -67B	-115
Prefix	Option Description											
A	Adaptor to next frame size	-	\$	\$	\$	\$	\$	\$	\$	\$	\$	\$
AA	Double Adaptor to 2nd larger frame size	-	-	-	-	-	-	-	-	-	-	\$
AB	Reverse Adaptor to next smaller frame size	-	-	\$	\$	\$	\$	\$	\$	\$	\$	\$
B	Aluminum Bronze Stat Disc (Per Disc) (Number of Stat Discs=# Rotating Discs +1)	-	-	-	-	-	-	-	-	-	-	-
C	Conduit Box	-	-	\$		\$	\$	\$				
DD	Direct Current (DC Voltage)	\$	\$	\$	-	\$	\$	\$	\$	\$	-	\$
DA	Drain Hole Special	-	-	*	-	*	*	*	*	*	-	*
E	Ductile Iron Stat Discs Per Disc (4 Post) (Number of Stat Discs=# Rotating Discs +1)	-	-	-	-	-	-	-	-	-	-	-
F	Foot Mounting Bracket	-	-	\$	\$	\$	\$	\$	\$	\$	\$	\$
H	Heavy Duty Friction Discs/Hardened Hub	1st Disc	-	-	\$	-	\$	\$	\$	\$	\$	\$
		Each Add'l Disc	-	-	\$	-	\$	\$	\$	\$	\$	\$
J	High Tensile Stud***	-	-	-	-	-	-	-	-	-	-	-
K	External Breather	-	-	-	-	-	\$	-	\$	-	-	-
M	Marine/Maritime Duty Brake with MIL-SPEC paint per TT-P-645 & MIL-DTL-15090	-	-	\$	-	\$	\$	\$	-	-	*	\$
N	Marine/Maritime Duty Brake	-	-	\$	-	\$	\$	\$	-	-	*	\$
P	Tropical (Moisture/Fungus) Protection	-	-	\$	-	\$	\$	\$	\$	\$	\$	\$
Q	Class H Insulation	-	\$	\$	\$	\$	\$	\$	\$	\$	-	\$
R	Heater (Specify voltage)	-	-	\$	-	\$	\$	\$	\$	\$	-	\$
S	Stainless Stat Disc (Per Disc) (Number of Stat Discs=# Rotating Discs +1)	-	-	\$	-	\$	\$	\$	\$	\$	-	\$
T	Thru-Hole in cover for shaft extension	Cast Cover	-	-	-	-	\$	-	**	-	-	-
		Steel Cover	-	\$	\$	-	-	-	-	-	-	\$
VO	Vertical Mount Over Motor- cost per disc	-	-	\$	\$	\$	\$	\$	\$	\$	\$	\$
VU	Vertical Mount Under Motor- cost per disc	-	-	\$	\$	\$	\$	\$	\$	\$	\$	\$
W	Electronic Wear Indicator Switch	-	-	-	-	-	-	-	-	-	-	-
X	Special Modifications	*	*	*	*	*	*	*	*	*	*	*
XE	Smart Brake Encoder Option	-	-	\$	-	-	\$	-	\$	-	-	\$
XS	Micro Switch (Brake Released/Engaged)	-	-	\$	-	\$	\$	\$	\$	\$	-	\$
XT	Tach Mounting (Cast Cover Only)	-	-	**	-	-	\$	-	\$	-	-	**
Y	Manual Release Handle	-	-	\$	-	\$	\$	\$	\$	\$	-	\$
Z	Stabilizer Clip Rotating (Per Rotating Disc)	-	\$	\$	-	Std.	\$	Std.	\$	Std.	\$	\$
	One Piece Hub/Shaft (Brakes 1-6 lb.ft. only)	-	-	-	-	\$	-	\$	-	\$	-	-
	Corrosion Resistant Internal Parts	-	-	\$	-	\$	\$	\$	Std.	Std.	\$	\$
	Deadman Release	-	Std.	-	-	-	-	-	-	-	-	-
	Non Standard Voltages	\$	\$	\$	\$	\$	\$	\$	\$	\$	\$	\$
	Non Standard Bore Sizes	\$	\$	\$	\$	\$	\$	\$	\$	\$	\$	\$

*-Contact your Local Dings Dynamics Distributor or Factory Representative for availability and pricing.

Brake Option List Price Additions

BACK TO TABLE
OF CONTENTS

Specification Number→	70 Series								80 Series			90 Series			
	NEMA 2		NEMA 4		NEMA 4X		NEMA 2	NEMA 4	Haz Location	NAVY	NEMA 2	NEMA 4	NAVY	NEMA 2	NEMA 4
	End Mount	CC	End Mount	CC	End Mount	CC	Foot Mounted	Foot Mounted	End Mount	End Mount	End Mount	End Mount	End Mount	End Mount	End Mount
	-ES41 -EC41 -ES4S -EC4S	-CE41 -CE42	-EC61 -SC61 -SC6S	-CE61 -CE62	-EC6W -SC6W -SC6T	-CE63 -CE64	-DE41	-DE61	-9	-42 -85	-28 -58	-29 -32	-27 -52	-50	-51 -52

Prefix	Option Description															
A	Adaptor to next frame size	\$	\$	\$	\$	\$	\$	-	-	\$	\$	\$	\$	\$	\$	\$
AA	Double Adaptor to 2nd larger frame size	\$	\$	\$	\$	\$	\$	-	-	\$	\$	\$	\$	\$	-	-
AB	Reverse Adaptor to next smaller frame size	\$	\$	\$	\$	\$	\$	-	-	\$	\$	\$	\$	\$	\$	\$
B	Aluminum Bronze Stat Disc Per Disc (Number of Stat Discs =# Rotating Discs-1)	-	-	-	-	-	-	-	-	-	-	\$	\$	-	\$	\$
C	Conduit Box	\$	\$	\$	\$	\$	-	\$	\$	-	-	\$	\$	-	\$	\$
DA	Drain Hole Special	*	*	*	*	*	*	*	*	*	*	*	*	*	*	*
E	Ductile Iron Stat Discs Per Disc (Number of Stat Discs=# Rotating Discs-1)	-	-	-	-	-	-	-	-	-	-	\$	\$	-	-	-
F	Foot Mounting Bracket	\$	\$	\$	\$	\$	\$	Std.	Std.	\$	\$	\$	\$	\$	\$	\$
H	Heavy Duty Friction Discs/Hardened Hub	1st Disc	\$	\$	\$	\$	\$	\$	\$	\$	\$	\$	\$	\$	\$	\$
		Each Add'l Disc	\$	\$	\$	\$	\$	\$	\$	\$	\$	\$	\$	\$	\$	\$
J	High Tensile Stud	-	-	-	-	-	-	-	-	Std.	\$	\$	\$	\$	Std.	Std.
K	External Breather	\$	\$	\$	\$	\$	\$	\$	\$	-	\$	\$	\$	\$	\$	\$
M	Marine/Maritime Duty Brake, MIL-SPEC paint per TT-P-645 & MIL-DTL-15090	\$	\$	\$	\$	-	-	\$	\$	*	Std.	\$	\$	Std.	\$	\$
N	Marine/Maritime Duty Brake	\$	\$	\$	\$	-	-	\$	\$	*	-	\$	\$	-	\$	\$
P	Tropical (Moisture/Fungus) Protection	\$	\$	\$	\$	\$	\$	\$	\$	\$	\$	\$	\$	\$	\$	\$
Q	Class H Insulation	Std.	Std.	Std.	Std.	Std.	Std.	Std.	Std.	\$	\$155	Std.	Std.	Std.	Std.	Std.
R	Heater (Specify voltage)	\$	\$	\$	\$	\$	\$	\$	\$	\$	\$	\$	\$	\$	\$	\$
S	Stainless Stationary Disc (Per Disc)	\$	\$	\$	\$	\$	\$	\$	\$	-	Std.	\$	\$	Std.	\$	\$
T	Thru-Hole in cover for shaft extension	Cast Cover	\$	-	\$	-	\$	-	-	-	-	\$	\$	-	\$	\$
		Steel Cover	\$	-	-	-	-	-	-	-	-	-	\$	-	-	-
VO	Vertical Mount Over Motor-cost per disc	\$	\$	\$	\$	\$	\$	\$	\$	\$	\$	\$	\$	\$	\$	\$
VU	Vertical Mount Under Motor-cost per disc	\$	\$	\$	\$	\$	\$	\$	\$	\$	\$	\$	\$	\$	\$	\$
W	Electronic Wear Indicator Switch	*	*	*	*	*	*	*	*	-	*	*	*	*	-	-
X	Special Modifications	*	*	*	*	*	*	*	*	*	*	*	*	*	*	*
XE	Smart Brake Encoder Option	\$	-	\$	-	\$	-	-	-	-	-	\$	\$	-	\$	\$
XS	Micro Switch (Brake Released/Engaged)	\$	\$	\$	\$	\$	\$	\$	\$	-	\$	\$	\$	\$	\$	\$
XT	Tach Mounting (Cast Cover Only)	\$	-	\$	-	-	-	-	-	-	-	\$	\$	-	\$	\$
Y	Manual Release Handle	Std.	Std	Std.	Std	-	Std.	Std	Std	Std	Std	-	-	-	-	-
	Corrosion Resistant Internal Parts	*	\$	*	\$	*	Std.	\$	\$	\$	Std.	\$	\$	Std.	\$	\$
	Deadman Release	*	*	*	*	*	*	*	*	*	Std.	*	*	Std.	-	-
	Non Standard Voltages	\$	\$	\$	\$	\$	\$	\$	\$	\$	\$	\$	\$	\$	\$	\$
	Non Standard Bore Sizes	\$	\$	\$	\$	\$	\$	\$	\$	\$	\$	\$	\$	\$	\$	\$
	External Release (Mark II Release)	-	-	-	-	-	-	-	-	-	-	\$	\$	-	-	-
	External Release (Mark III Release)	-	-	-	-	-	-	-	-	-	-	\$	\$	-	-	-

*Contact your Local Dings Dynamics Distributor or Factory Representative for availability and pricing.

TABLE OF SYMBOLS	
W_B	Weight of overhauling load
W_B	Total weight of load acting at motor brake
V_B	Linear velocity of load subjected to linear motion
Θ_B	Angle of inclination for overhauling load
WK_B	Total rotational moment of inertia acting at motor brake
N_B	Rotational speed of load
N_B	Rotational speed of brake
T_B	Torque required at brake to hold overhauling load
T_{BM}	Minimum brake torque to stop and hold application
T_{SB}	Torque rating of selected brake
t_{SB}	Stopping time of application using selected brake
TDSB	Total distance travelled by linear load during stop
HPSB	Horsepower seconds per stop
ASMB	Allowable stops per minute
RTCB	Rated thermal capacity of brake

The procedure for sizing a brake in an application subjected to overhauling loads has four steps:

- I. Determine rotational moment of inertia acting at motor brake.
- II. Determine minimum torque required to stop and hold system.
- III. Calculate system performance using selected brake.
- IV. Evaluate system performance.

Before starting this process, the following application information is needed to conduct the sizing calculations:

- ♦ A detailed sketch of the brake-motor application.
- ♦ Motor data, including horsepower rating, speed (rpm), rotational inertia (lb-ft²) and NEMA frame size.
- ♦ Rotational inertia (lb-ft²) of all system components acting at the brake.
- ♦ Rotational speed (rpm) of all system components acting at the brake.
- ♦ Weight (lbs) and velocity (ft/min) of loads subjected to linear motion.
- ♦ Angle of inclination if overhauling load is not acting vertically.
- ♦ Cycle rate of system (stops/min).

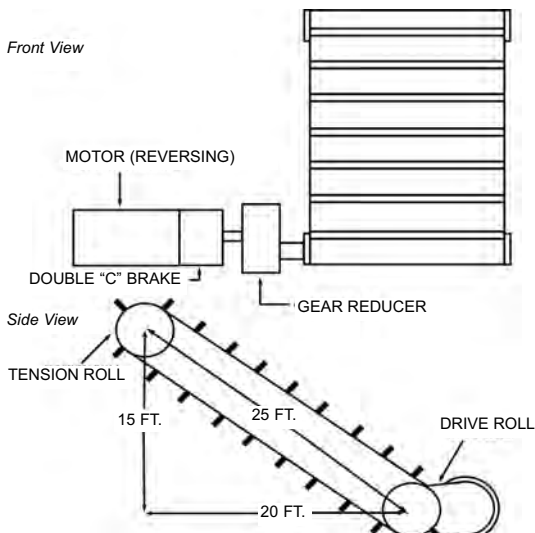

Example: Application Information for Bucket Conveyor

Motor Data:

Horsepower Rating	5 HP
Speed	1,760 RPM
Rotational Inertia	0.30 lb-ft ²
NEMA Frame Size	184 TC

Rotational Inertia of All Active System Components:

Motor Brake Data:

Rotational Inertia	0.11 lb-ft ²
--------------------	-------------------------

Gear Reducer Data:

Gear Reduction Ratio	50:1
Gear Reducer Inertia	0.14 lb-ft ²

Drive Roll Data:

Roll Diameter	0.955 ft
Roll Length	2.5 ft
Rotational Inertia	99.338 lb-ft ²
Tension Roll Data	Same as Drive Roll

Rotational Speed of All Components Acting at Brake:

Motor	1,760 RPM
Brake	1,760 RPM
Gear Reducer	1,760 RPM (in)
	35.2 RPM (out)
Drive Roll	35.2 RPM
Tension Roll	35.2 RPM

Weight and Velocity of Loads Subjected to Linear Motion:

For this example, we will use the following conveyor data:

Empty weight of conveyor belt (per foot basis)	15 lbs
Total length of conveyor belt	53 ft
Empty weight of conveyor bucket	20 lbs
Spacing of buckets on conveyor	1 ft
Total number of buckets on conveyor	52
Load capacity of each bucket	75 lbs

$$W_C = (53 \text{ ft})(15 \text{ lb/ft}) + (52)(20 \text{ lbs}) = 1,835 \text{ lbs}$$

$$W_L = (0.5)(52)(75 \text{ lbs}) = 1,950 \text{ lbs}$$

**The W_L calculation assumes that only half of the buckets will carry a load at any given instant.*

$$W = W_C + W_L = 3,785 \text{ lbs}$$

(For velocity calculations)

$$V_L = (35.2 \text{ rev/min})(0.955 \text{ ft})\pi = 105.6 \text{ ft/min}$$

Angle of Inclination:

$$\Theta = \text{SIN}^{-1}\left(\frac{H}{L}\right) = \text{SIN}^{-1}\left(\frac{15}{25}\right) = 36.87^\circ$$

$$\text{SIN } \Theta = 0.600$$

Then: (For weight calculations)

Cyclic Rate of System:

Maximum of 2 stops/minute.

Using the application information, select a brake for this system.

Application Engineering- Overhauling Loads

I. DETERMINE ROTATIONAL MOMENT OF INERTIA ACTING AT MOTOR BRAKE

Known Quantities:

Motor	0.3000 lb-ft ²
Brake	0.1100 lb-ft ²
Gear Reducer	0.1400 lb-ft ²

(A) Contribution from rotary load at different speed than brake shaft:
(For Drive Roller)

$$WK_{DR}^2 = WK_{DRD}^2 \left(\frac{N_L}{N_B} \right)^2 = (99.338 \text{ lb-ft}^2) \left(\frac{35.2}{1760} \right)^2 = 0.0397 \text{ lb-ft}^2$$

(For Tension Roller)

$$WK_{TR}^2 = WK_{TRD}^2 \left(\frac{N_L}{N_B} \right)^2 = (99.338 \text{ lb-ft}^2) \left(\frac{35.2}{1760} \right)^2 = 0.0397 \text{ lb-ft}^2$$

**This assumes that there is no slippage between conveyor belt and rollers.*

(B) Contribution from loads subjected to linear motion:

$$WK_L^2 = W \left(\frac{V_L}{2\pi N_B} \right)^2 = (3,785 \text{ lbs}) \left(\frac{105.6}{2\pi 1760} \right)^2 = 0.3452 \text{ lb-ft}^2$$

Then:

$$WK_T^2 = WK_M^2 + WK_B^2 + WK_{GR}^2 + WK_{DR}^2 + WK_{TR}^2$$

$$WK_T^2 = 0.9746 \text{ lb. ft.}^2$$

II. DETERMINE MINIMUM TORQUE REQUIRED TO STOP AND HOLD SYSTEM

(A) Calculate overhauling torque of fully loaded conveyor belt:

$$T_O = \frac{(0.158)(\sin(\Theta))(W_L)(V_L)}{N_B}$$

$$T_O = \frac{(0.158)(0.600)(1950 \text{ lb})(105.6 \text{ ft/min})}{1760 \text{ RPM}} = 11.092 \text{ lb. ft.}$$

(B) Calculate minimum brake torque:

$$T_{BM} = \frac{(WK_T^2)(N_B)}{308t} + T_O$$

$$T_{BM} = \frac{(0.9746 \text{ lb. ft.}^2)(1760)}{(308)(1)} + 11.092 \text{ lb. ft.}$$

$$T_{BM} = 5.569 \text{ lb. ft.} + 11.092 \text{ lb. ft.} = 16.661 \text{ lb. ft.}$$

Please note that the maximum stopping time should not exceed one second.

Therefore, we must select a brake with a torque rating of at least 16.661 lb-ft which fits on a NEMA 184 TC frame size.

Selected Brake Data:

Dings Model Number	4-72025-46
Enclosure Type	NEMA 4
Brake Style	Double "C" Face
Rated Thermal Capacity	12
Rotational Inertia	0.1097 lb-ft ²

III. CALCULATE SYSTEM PERFORMANCE USING SELECTED BRAKE

(A) Stopping time calculation:

$$t_{SB1} = \frac{(WK_T^2)(N_B)}{(308)(T_{SB} + T_O)} = \frac{(0.9746 \text{ lb. ft.}^2)(1760)}{(308)(25+11.092)} = 0.154 \text{ sec}$$

$$t_{SB4} = \frac{(WK_T^2)(N_B)}{(308)(T_{SB} - T_O)} = \frac{(0.9746 \text{ lb. ft.}^2)(1760)}{(308)(25-11.092)} = 0.400 \text{ sec}$$

(B) Travel distance during stop calculations:

$$TDS_1 = \frac{0.5 V_L t_{SB1}}{60} = \frac{(0.5)(105.6 \text{ ft/min})(0.154 \text{ s})}{60} = 0.136 \text{ ft}$$

$$TDS_4 = \frac{0.5 V_L t_{SB4}}{60} = \frac{(0.5)(105.6 \text{ ft/min})(0.400 \text{ s})}{60} = 0.352 \text{ ft}$$

(C) Thermal requirement calculations:

(without overhauling load)

$$\text{H.P. Sec/Stop} = WK_T^2 \left(\frac{N_B}{1800} \right)^2 = (0.9746 \text{ lb. ft.}^2) \left(\frac{1760}{1800} \right)^2 = 0.932 \text{ HPS/Stop}$$

(with ascending overhauling load)

$$\begin{aligned} \text{H.P. Sec/Stop}_{ot} &= \text{H.P. Sec/Stop} \left(\frac{T_{SB}}{T_{SB} + T_O} \right) \\ &= (0.932) \left(\frac{25}{25+11.092} \right) = 0.646 \text{ HPS/Stop}_{ot} \end{aligned}$$

(with descending overhauling load)

$$\begin{aligned} \text{H.P. Sec/Stop}_{oi} &= \text{H.P. Sec/Stop} \left(\frac{T_{SB}}{T_{SB} - T_O} \right) \\ &= (0.932) \left(\frac{25}{25-11.092} \right) = 1.675 \text{ HPS/Stop}_{oi} \end{aligned}$$

Since the worst case scenario is a descending overhauling load, it will be used to determine allowable stops:

(D) Allowable stops calculation:

$$\text{ASM} = \frac{\text{RTC}}{\left(\frac{\text{HPS}_{oi}}{\text{MIN}} \right)} = \frac{12}{1.675} = 7.16 \frac{\text{STOPS}}{\text{MIN}}$$

IV. EVALUATE SYSTEM PERFORMANCE

(1) Stopping time of system is less than one second so brake torque is adequate.

(2) Allowable stops per minute is more than three times the specified number of two, so rated thermal capacity is adequate.

Therefore, we can conclude that the brake will function as intended.

Product Warranty

[BACK TO TABLE
OF CONTENTS](#)

Seller warrants products manufactured by it and supplied hereunder to be free from defects in material and workmanship under normal use and proper maintenance for a period of twelve months from date of shipment. If within such period any such products shall be proved to Seller's reasonable satisfaction to be defective, such products shall be repaired or replaced at Seller's option. Seller's obligation and Buyer's exclusive remedy hereunder shall be limited to such repair and replacement and shall be conditioned upon Seller's receiving written notice of any alleged defect no later than 10 days after its discovery within the warranty period and, at Seller's option, the return of such products to Seller, f.o.b. its factory, when such return is feasible. Seller reserves the right to satisfy its warranty obligation in full by reimbursing Buyer for all payments it makes hereunder, and Buyer shall thereupon return the products to Seller. Seller shall have the right to remedy such defects. Seller makes no warranty with respect to wear or use items, such as belts, chains, sprockets, discs and coils, all of which are sold strictly AS IS.

The foregoing warranties are exclusive and in lieu of all other express and implied warranties (except of title) including but not limited to implied warranties of merchantability, fitness for a particular purpose, performance or otherwise, and in no event shall the Seller be liable for claims (based upon breach of express or implied warranty, negligence, product liability, or otherwise) for any other damages, whether direct, immediate, incidental, foreseeable, consequential, or special.

Conversions

Measurement	Base Unit	Convert to	Factor
Torque	pound-feet (lb-ft)	Newton-meter (Nm)	1.355818
	Newton-meter (Nm)	pound-feet (lb-ft)	.73756
	pound-inches (lb-in)	Newton-meter (Nm)	.113
	Newton-meter (Nm)	pound-inches (lb-in)	8.85
	ounce-inches (oz-in)	Newton-meter (Nm)	.007062
	Newton-meter (Nm)	ounce-inches (oz-in)	141.611
Horsepower	horsepower (hp)	kilowatt (Kw)	.7457
	kilowatt (Kw)	horsepower (hp)	1.341
Weight	pound (lb)	kilogram (kg)	.453592
	kilogram (kg)	pound (lb)	2.20462
Inertia	pound-feet squared (lb-ft ²)	kilogram-meter squared (kgm ²)	.042
	kilogram-meter squared (kgm ²)	pound-feet squared (lb-ft ²)	23.81
Length	inch	millimeter (mm)	25.4
	millimeter (mm)	inch	.03937

Sales Offices

BACK TO TABLE
OF CONTENTS



Company	Address	City	State	Phone No	Fax No
①	Contact Factory			414-672-7830	414-672-5354
②	Contact Factory			414-672-7830	414-672-5354
③	Contact Factory			414-672-7830	414-672-5354
④	Contact Factory			414-672-7830	414-672-5354
⑤	Contact Factory			414-672-7830	414-672-5354
⑥	Contact Factory			414-672-7830	414-672-5354
⑦	Contact Factory			414-672-7830	414-672-5354
⑧	Contact Factory			414-672-7830	414-672-5354
⑨	Contact Factory			414-672-7830	414-672-5354
⑩	Contact Factory			414-672-7830	414-672-5354

Model Number Index - Cross Reference to Stearns® Model Numbers

[BACK TO TABLE
OF CONTENTS](#)

48C FRAME END MOUNT BRAKE			
Torque lb-ft	Dings Model #	Stearns® Model Number	Page Number
NEMA 2, IP40 Enclosure			
1.5	51001-050	1-048-151-01	4
3	51003-050	1-048-161-01	4
6	51006-050	1-048-171-01	4
1.5	51001-080	1-048-151-00	4
3	51003-080	1-048-161-00	4
6	51006-080	1-048-171-00	4

56C/143-145TC FRAME DOUBLE C FACE BRAKE			
Torque lb-ft	Dings Model #	Stearns® Model Number	Page Number
NEMA 2 / IP41 Enclosure			
1.5	61001-551	1-056-701-0X	13
3	61003-551	1-056-711-0X	13
6	61006-551	1-056-721-0X	13
10	62010-551	1-056-731-0X	13
15	63015-551	1-056-741-0X	13
20	63020-551	1-056-751-0X	13
NEMA 4 / IP56 Enclosure			
1.5	61001-5153	1-056-702-0X	13
3	61003-5153	1-056-712-0X	13
6	61006-5153	1-056-722-0X	13
10	62010-5153	1-056-732-0X	13
15	63015-5153	1-056-742-0X	13
20	63020-5153	1-056-752-0X	13
NEMA 4X / IP56 Enclosure			
1.5	61001-5155	1-056-704-0X	13
3	61003-5155	1-056-714-0X	13
6	61006-5155	1-056-724-0X	13
10	62010-5155	1-056-734-0X	13
15	63015-5155	1-056-744-0X	13
20	63020-5155	1-056-754-0X	13
NEMA 4X / IP56 Stainless Steel			
3	61003-5145	1-056-71S-0X	13
6	61006-5145	1-056-72S-0X	13
10	62010-5145	1-056-73S-0X	13
15	63015-5145	1-056-74S-0X	13
20	63020-5145	1-056-75S-0X	13

56C/143-145TC FRAME END MOUNT BRAKE			
Torque lb-ft	Dings Model #	Stearns® Model Number	Page Number
NEMA 2 / IP41 Enclosure			
1.5	61001-5601	1-056-001-00	5
3	61003-5601	1-056-011-00	5
6	61006-5601	1-056-021-00	5
10	62010-5601	1-056-031-00	5
15	62015-5601	1-056-041-00	5
20	63020-5601	1-056-051-00	5
25	63025-5601	1-056-061-00	5
1.5	61001-524	1-056-001-00	7
3	61003-524	1-056-011-00	7
6	61006-524	1-056-021-00	7
10	62010-524	1-056-031-00	7
15	63015-524	1-056-041-00	7
20	63020-524	1-056-051-00	7
25	64025-524	1-056-061-00	7
NEMA 4 / IP56 Enclosure			
1.5	61001-535	1-056-002-00	11
3	61003-535	1-056-012-00	11
3	61003-530	1-056-212-00	11
6	61006-535	1-056-022-00	11
6	61006-530	1-056-222-00	11
10	62010-535	1-056-032-00	11
10	62010-530	1-056-232-00	11
15	63015-535	1-056-042-00	11
15	63015-530	1-056-242-00	11
20	63020-535	1-056-052-00	11
20	63020-530	1-056-252-00	11
25	64025-530	1-056-262-00	11
1.5	61001-545	1-056-002-80	9
3	61003-545	1-056-012-80	9
6	61006-545	1-056-022-80	9
10	62010-545	1-056-032-80	9
15	63015-545	1-056-042-80	9
20	63020-545	1-056-052-80	9
NEMA 4X / IP56 Enclosure			
3	61003-5116	1-056-214-00	11
3	61003-5140	1-056-914-00	11
6	61006-5116	1-056-224-00	11
6	61006-5140	1-056-924-00	11
10	62010-5116	1-056-234-00	11
10	62010-5140	1-056-934-00	11
15	63015-5116	1-056-244-00	11
15	63015-5140	1-056-944-00	11
20	63020-5116	1-056-254-00	11
20	63020-5140	1-056-954-00	11
25	64025-5116	1-056-264-00	11
25	64025-5140	1-056-964-00	11

Stearns® is a Registered Trademark of Rexnord Corporation

Model Number Index - Cross Reference to Stearns® Model Numbers

182/184TC-254/256TC FRAME END MOUNT BRAKE			
Torque lb-ft	Dings Model #	Stearns® Model Number	Page Number
NEMA 2 / IP43 Enclosure			
10	71010-ES4S	1-087-011-00	17
15	71015-ES4S	1-087-021-00	17
25	71025-ES4S	1-087-031-00	17
35	72035-ES4S	1-087-041-00	17
50	72050-ES4S	1-087-051-00	17
75	73075-ES4S	1-087-061-00	17
105	2174105-ES4S	1-087-081-00	17
NEMA 4 / IP56 Enclosure			
10	71010-SC6S	1-087-012-00	21
15	71015-SC6S	1-087-022-00	21
25	71025-SC6S	1-087-032-00	21
35	72035-SC6S	1-087-042-00	21
50	72050-SC6S	1-087-052-00	21
75	73075-SC6S	1-087-062-00	21
105	74105-SC6S	1-087-082-00	21
NEMA 4X / IP56 Enclosure			
10	71010-SC6T	1-087-012-B0	23
15	71015-SC6T	1-087-022-B0	23
25	71025-SC6T	1-087-032-B0	23
35	72035-SC6T	1-087-042-B0	23
50	72050-SC6T	1-087-052-B0	23
75	73075-SC6T	1-087-062-B0	23
105	74105-SC6T	1-087-082-B0	23

284TC/UC-286TC/UC FRAME END MOUNT BRAKE			
Torque lb-ft	Dings Model #	Stearns® Model Number	Page Number
NEMA 2 / IP41 Enclosure			
25	81025-58	1-087-031-00 with adaptor	41
35	81035-58	1-087-041-00 with adaptor	41
50	82050-58	1-087-151-00	41
75	83075-58	1-087-161-00	41
105	83105-58	1-087-181-00	41
125	84125-58	1-087-191-00	41
175	85175-58	1-082-021-02 with adaptor	41
NEMA 4 / IP56 Enclosure			
25	81025-29	1-087-032-00 with adaptor	45
35	81035-29	1-087-042-00 with adaptor	45
50	82050-29	1-087-151-00	45
75	83075-29	1-087-161-00	45
105	83105-29	1-087-181-00	45
125	84125-29	1-087-191-00	45
175	85175-29	1-082-022-02 with adaptor	45

182/184TC-254/256TC FRAME DOUBLE C FACE BRAKE			
Torque lb-ft	Dings Model #	Stearns® Model Number	Page Number
NEMA 2 / IP43 Enclosure			
10	71010-CE42	1-087-711-0X	31
15	71015-CE42	1-087-721-0X	31
25	71025-CE42	1-087-731-0X	31
35	72035-CE42	1-087-741-0X	31
50	72050-CE42	1-087-751-0X	31
75	73075-CE41	1-087-761-0X	31
105	74105-CE41	1-087-781-0X	31
NEMA 4 / IP56 Enclosure			
10	71010-CE62	1-087-712-0X	33
15	71015-CE62	1-087-722-0X	33
25	71025-CE62	1-087-732-0X	33
35	72035-CE62	1-087-742-0X	33
50	72050-CE62	1-087-752-0X	33
75	73075-CE61	1-087-762-0X	33
105	74105-CE61	1-087-782-0X	33
NEMA 4X / IP56			
10	71010-CE64	1-087-712-BX	35
15	71015-CE64	1-087-722-BX	35
25	71025-CE64	1-087-732-BX	35
35	72035-CE64	1-087-742-BX	35
50	72050-CE64	1-087-752-BX	35
75	73075-CE63	1-087-762-BX	35
105	74105-CE63	1-087-782-BX	35

324TC/UC-405TC/UC FRAME END MOUNT BRAKE			
Torque lb-ft	Dings Model #	Stearns® Model Number	Page Number
NEMA 2 / IP41 Enclosure			
125	92125-50	1-082-011-02	47
180	92180-50	1-082-021-02	47
230	93230-50	1-082-031-02	47
330	94330-50	1-082-041-02	47
450	95450-50	1-082-051-02	47
NEMA 4 / IP56 Enclosure			
125	92125-51	1-082-012-02	47
180	92180-51	1-082-022-02	47
230	93230-51	1-082-032-02	47
330	94330-51	1-082-042-02	47
450	95450-51	1-082-052-02	47

Stearns® is a Registered Trademark of Rexnord Corporation

Magnetic Separators Product Line

Providing Separation Solutions Since 1899

Dings magnetic separators for ferrous and nonferrous metals are used in a wide variety of industries such as **Construction/Demolition, Foundry, Mining & Aggregate, Recycling, and Scrap.**

In addition to ensuring product purity, they prevent costly repairs and downtime by protecting processing equipment from damaging metal. Reclaiming metals, recovering saleable materials, and concentrating minerals are other important uses for Dings products.

Product Overview

10-YEAR WARRANTY against coil burnout

Overhead Magnets

Overhead separators suspend above belt or vibratory conveyors, magnetically lifting ferrous metals out of bulk material. Separated steel objects are held against the magnet until removed – automatically on self-cleaning models, or manually on stationary models.



Our innovative coil design allows us to offer the LONGEST WARRANTY IN THE INDUSTRY against coil burnout.

Types:

- Electromagnets – Self-Cleaning or Stationary
- Permanent Magnets – Self-Cleaning or Stationary
- Severe Duty - Self-Cleaning
- Solid Waste Magnetic Systems

Lifetime Guarantee on Magnetism

Magnetic Head Pulleys

Dings Perma Pulleys are permanent (nonelectric) magnetic separators that operate as head pulleys on belt conveyors. These low-cost, self-cleaning magnets remove tramp iron and purify materials conveyed in bulk form.



Our Patented Flux Control Circuit Provides Ultimate Magnetic Power allowing us to offer a LIFETIME GUARANTEE on magnetism

Lifetime Guarantee on Magnetism

Magnetic Drums

The Deep Draw Drums is a permanent self-cleaning separator. Its rugged construction is ideal for separating ferrous metal from material such as shredded cars, slag, crushed ore, and ash at mass burn plants. Electromagnetic drums are also available for scrap recycling.



Type:

- Self-Cleaning Permanent & Electromagnetic Scrap Recycling Drums

Eddy Current Separators

The Eddy Current Separator is ideal for recovering nonferrous metals from recyclables, plastics, glass, material processed at composting or waste-to-energy facilities, automotive shredder residue, and other processed materials.



Services

In-House Testing

Unsure which product is best for your application? Send us a sample of your product with a description of what you are trying to accomplish. We'll test it on equipment in-house at no charge, and recommend the best equipment for your particular application.

Custom Design

Our highly experienced sales engineers will work with you to design the perfect separator for your application.

Our engineers will provide certified prints prior to production to ensure everything meets your requirements.

Rebuilds

If your magnet has been damaged, consider having Dings rebuild it. In many cases, we can bring a magnet back to near-new condition at a cost substantially less than that of a new one.